



**HERRAMIENTAS
DE CORTE**
CATÁLOGO

CUTTING TOOLS
CATALOGUE



2021v.SP



DISEÑO Y FABRICACIÓN

HERRAMIENTAS DE CORTE Y
ACCESORIOS PARA HERRAMIENTA
ELECTROPORTÁTIL



Tivoly (NECO) es el primer fabricante nacional de herramienta de corte. Con la gama más completa del mercado (brocas, machos de roscar, fresas, escariadores, avellanadores, rodillos, peines y herramienta especial), un servicio de asistencia técnica y un departamento de I+D+i propio, **NECO** es el principal referente de la herramienta de corte, capaz de garantizarlas más altas exigencias de calidad que demanda el mercado actual.

DESIGNER & MANUFACTURER

CUTTING TOOLS & POWER TOOL
ACCESSORIES

Tivoly (NECO) is one of the major manufacturers of cutting tools. With one of the widest ranges in the market (drills, taps, milling cutters, reamers, countersinks reamers, rollers, screw chasers and special tool), a technical assistance service as well as an own R+D+i department, **Tivoly** is one of the main references in the cutting tool, being capable to guarantee the highest quality requirements demanded by the current market.

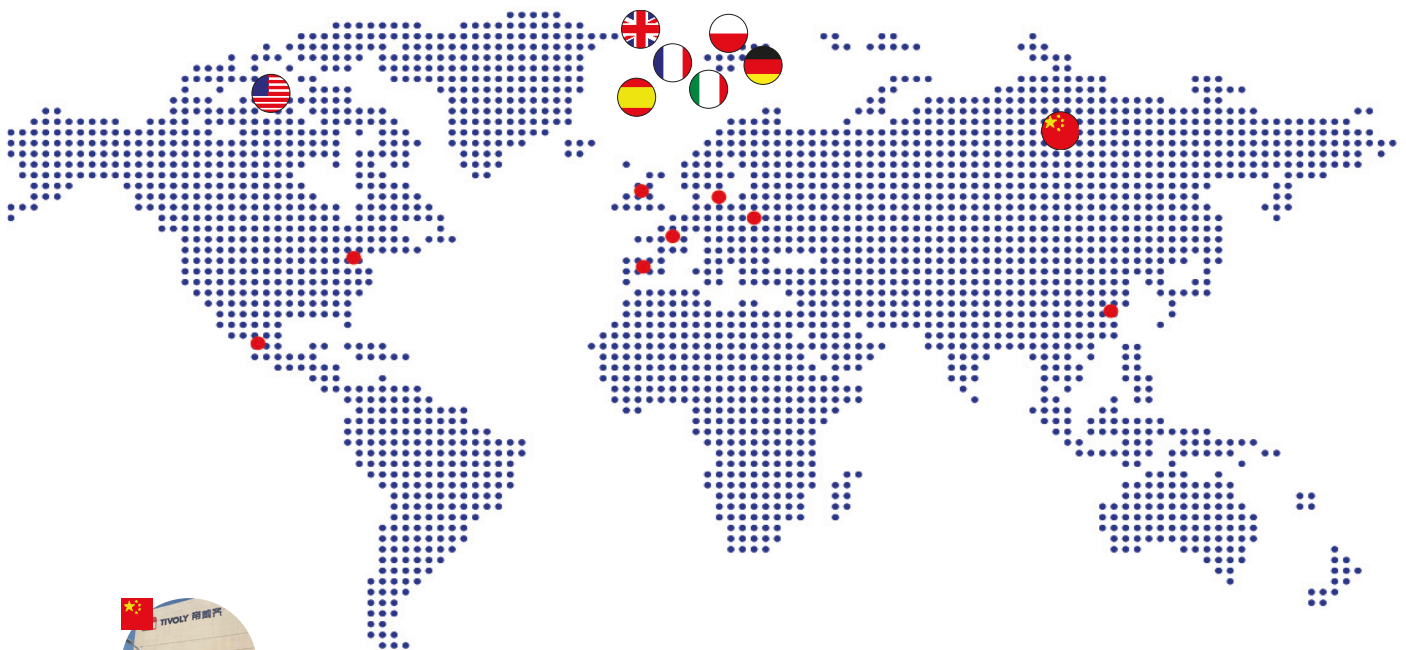

PRESENCIA INTERNACIONAL

Tivoly (NECO) está integrado dentro de la multinacional francesa Groupe Tivoly, uno de los líderes mundiales en la fabricación de herramientas de corte y laminación, que cuenta con centros productivos en Francia, España, EE.UU, Inglaterra y China.

INTERNATIONAL PRESENCE

Tivoly (NECO) is integrated in to the French multinacional Groupe Tivoly, one of the world wide leading groups in the manufacturing of cutting and rolling tools, which has productive centres in France, Spain, U.S.A, England and China.

PROCESO FABRICACIÓN DE MACHOS | TAPS MANUFACTURING PROCESS

1 MATERIA PRIMA



2 CORTE / TORNEADO



TIVOLTM

**3 TRATAMIENTO
TÉRMICO**



4 ACANALADO



5 ROSCADO



6 CONTROL FINAL

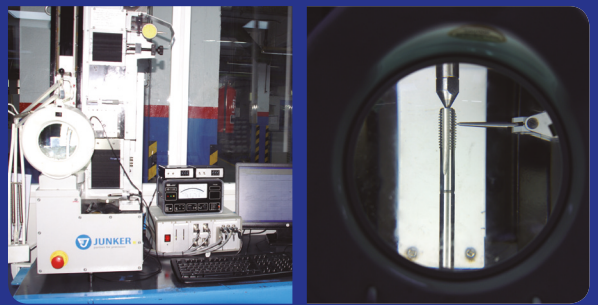

**7 MARCADO LASER
ENVASADO**



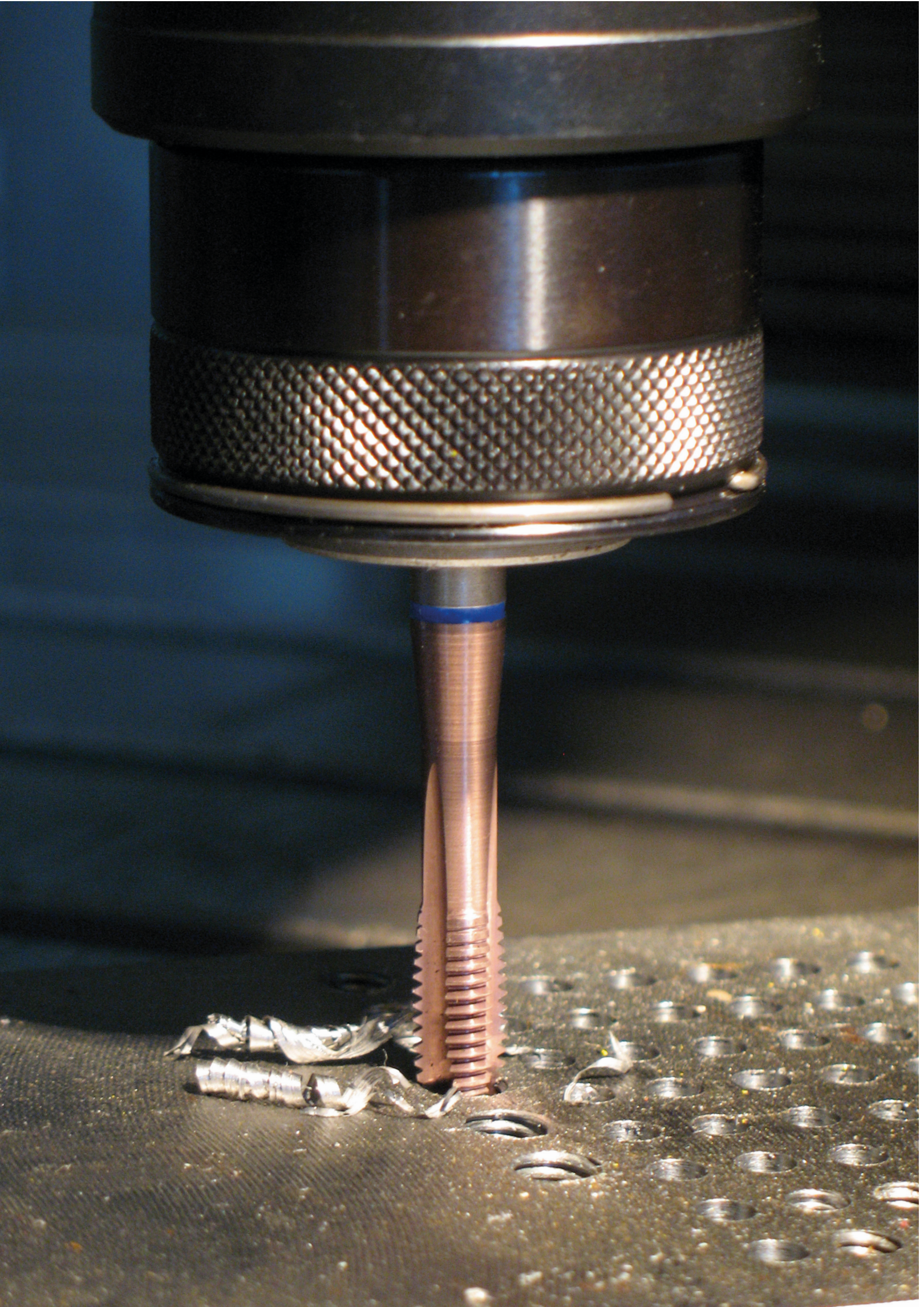

ÍNDICE GENERAL

2021

HERRAMIENTAS DE CORTE

CUTTING TOOLS

TALADRADO | DRILLING :

- **BROCAS ACERO RÁPIDO** | HSS BITS
- **BROCAS METAL DURO** | HM BITS



FRESAS HUECAS | CORE HOLE DRILLING :

- **FRESAS PARA TALADRO MAGNÉTICO** |
CORE HOLE DRILLING



MACHOS & COJINETES | TAPPING & THREADING :

- **MACHOS ESTÁNDAR** | STANDARD TAPS
- **MACHOS MULTI-APLICACIÓN** | MULTI-APP TAPS
- **MACHOS HI-PERFORMANCE FLASH CUT** |
HI-PERFORMANCE FLASH CUT TAPS
- **COJINETES** | DIES
- **ACCESORIOS & ESTUCHES** | ACCESSORIES & SETS



FRESADO | MILLING :

- **AVELLANADORES** | COUNTERSINKERS
- **FRESAS LIMA** | ROTARY BURRS
- **FRESAS HSS** | HSS END MILLS
- **FRESAS METAL DURO** | HM END MILLS



AFILADORES | SHARPENING

- **DRILL DOCTOR & ACCESORIOS** |
DRILL DOCTOR & ACCESSORIES



- **INFORMACIÓN TÉCNICA** |
TECHNICAL INFORMATION



TALADRADO
DRILLING

FRESAS HUECAS
CORE HOLE DRILLING

MACHOS & COJINETES
CORE HOLE DRILLING

FRESADO
MILLING











AFILADORES
SHARPENING

INFORMACIÓN TÉCNICA
TECHNICAL INFORMATION



CATÁLOGO GENERAL
2021

ÍNDICE
INDEX

	1140261	HSS	DIN 1897	STEAM TREATED	2xd	A	24
	1140281	HSS E5	DIN 1897	GOLD TREATED	2xd	AB F	25
	1140271	HSS	DIN 1897	BRIGHT UNCOATED	1xd	AB	26
	1143741	HSS	DIN 1897	BRIGHT UNCOATED	1xd	AB P	27
	8143911	HSS E5	DIN 1897	TIAIN TREATED	2xd	AB D FGH J M	28
	1145301	HSS	DIN 338	STEAM TREATED	3xd	A	30
	11453070015	HSS	DIN 338	STEAM TREATED	19 PCS	A	33
	11453070017	HSS	DIN 338	STEAM TREATED	25 PCS	A	33
	11453070024	HSS	DIN 338	STEAM TREATED	170 PCS	A	33
	11453070026	HSS	DIN 338	STEAM TREATED	222 PCS	A	33
	1143784	HSS	DIN 338	STEAM TREATED	3xd	A	34
	8140061	HSS	DIN 338	BRIGHT UNCOATED	3xd	A	35
	1145411	HSS	DIN 338	FUSIO COATED e3-13mm ONLY	3xd	AB C IJ	36
	11454170004	HSS	DIN 338	FUSIO COATED e3-13mm ONLY	10 PCS	AB C IJ	38
	11454170005	HSS	DIN 338	FUSIO COATED e3-13mm ONLY	06 PCS	AB C IJ	38
	11454170006	HSS	DIN 338	FUSIO COATED e3-13mm ONLY	13 PCS	AB C IJ	39
	11454170002	HSS	DIN 338	FUSIO COATED e3-13mm ONLY	26 PCS	AB C IJ	39
	11454170015	HSS	DIN 338	FUSIO COATED e3-13mm ONLY	19 PCS	AB C IJ	39

TALADRADO
DRILLING

FRESAS HUECAS
CORE HOLE DRILLING

MACHOS & COJINETES
CORE HOLE DRILLING

FRESADO
MILLING

AFILADORES
SHARPEING

INFORMACIÓN TÉCNICA
TECHNICAL INFORMATION



11454170017 ➤ HSS DIN 338 FUSIO COATED #3-13mm ONLY 25 PCS

AB C IJ

39



11454170009 ➤ HSS DIN 338 FUSIO COATED #3-13mm ONLY 32 PCS

AB C IJ

40



11454170010 ➤ HSS DIN 338 FUSIO COATED #3-13mm ONLY 51 PCS

AB C IJ

40



11454170011 ➤ HSS DIN 338 FUSIO COATED #3-13mm ONLY 41 PCS

AB C IJ

40

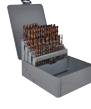

11454170008 ➤ HSS DIN 338 FUSIO COATED #3-13mm ONLY 91 PCS

AB C IJ

40



1145501 ➤ HSS E5 DIN 338 GOLD TREATED 3xd

A B F

41



11455070015 ➤ HSS E5 DIN 338 GOLD TREATED 19 PCS

A B F

43



11455070017 ➤ HSS E5 DIN 338 GOLD TREATED 25 PCS

A B F

43



1145561 ➤ HSS E5 DIN 338 GOLD TREATED 3xd

A B F

44



1145581 ➤ HSS E5 DIN 338 BRIGHT UNCOATED 3xd

F

45



11455870015 ➤ HSS E5 DIN 338 BRIGHT UNCOATED 19 PCS

F

47



11455870017 ➤ HSS E5 DIN 338 BRIGHT UNCOATED 25 PCS

F

47



1145611 ➤ HSS E5 DIN 338 BLADE COATED #3-13mm ONLY 3xd

F G H D

48



11456170015 ➤ HSS E5 DIN 338 BLADE COATED #3-13mm ONLY 19 PCS

F G H D

50



11456170017 ➤ HSS E5 DIN 338 BLADE COATED #3-13mm ONLY 25 PCS

F G H D

50



8140161 ➤ HSS E5 DIN 338 BRIGHT UNCOATED 3xd

ARCo ARNI Ti

51



1140561 ➤ HSS DIN 340 STEAM TREATED 7xd

A

53

	1140571							54
	1142061			>10xd icon" data-bbox="548 158 578 178"/>				55
	1143791							57
	1140981							58
	1141051							60
	1110341		CASQUILLO DE REDUCCIÓN TEMPLADO TEMPERED ADAPTER					61
	1110361		CASQUILLO DE REDUCCIÓN LARGO TEMPLADO TEMPERED ELONGATED ADAPTER					61
	1110371		EXTRACTOR DE CONOS CONE PUNCH					61
	1144862				CANAL RECTO STRAIGHT FLUTE			62
	11444870001				CANAL RECTO STRAIGHT FLUTE			62
	1144852				CANAL HELICOIDAL HELICOIDAL FLUTE			63
	11448570001				CANAL HELICOIDAL HELICOIDAL FLUTE			63
	1143872				CANAL HELICOIDAL HELICOIDAL FLUTE			64
	11438770001				CANAL HELICOIDAL HELICOIDAL FLUTE			64
	1144872				CANAL HELICOIDAL HELICOIDAL FLUTE			65
	11448770001				CANAL HELICOIDAL HELICOIDAL FLUTE			65
	8140891							66
	8140811							67

TALADRADO
DRILLING

FRESAS HUECAS
CORE HOLE DRILLING

MACHOS & COJINETES
CORE HOLE DRILLING

FRESADO
MILLING

AFILADORES
SHARPENING

INFORMACIÓN TÉCNICA
TECHNICAL INFORMATION

	8241501	HM CARB	DIN 6537K	3xd	TIAIN COATED		70
	8241701	HM CARB	DIN 6537K	5xd	TIAIN COATED		71
	8243921	HM CARB	DIN 338	3xd	BRIGHT UNCOATED		72
	8240201	HM CARB	simDIN 338	3xd	BRIGHT UNCOATED		74
	8240011	HM CARB			BRIGHT UNCOATED		76
	82400170001	HM CARB			BRIGHT UNCOATED		76
	1190184	DIN 8039	HM DIAM				77
	11901870001	DIN 8039	HM DIAM				77

	1037001	HSS	TIVOLY NORM		Z	WELDON 19mm	TIAIN COATED		80
	1037011	HSS	TIVOLY NORM		Z	WELDON 19mm	TIAIN COATED		81
	1037051	HSS	TIVOLY NORM		Z	WELDON 19mm	BRIGHT UNCOATED		82
	1037061	HSS	TIVOLY NORM		Z	WELDON 19mm	BRIGHT UNCOATED		83
	10370070001	HSS				WELDON 19mm	TIAIN COATED		84
	10370070005	HSS				WELDON 19mm	TIAIN COATED		84
	1037031	HSS	TIVOLY NORM		Z3	WELDON 19mm	BRIGHT UNCOATED		84
	1111121	TIVOLY NORM				WELDON 19mm		EXPULSORES PARA FRESA HUECA PILOT PIN FOR CORE HOLE DRILL	85
	1111151	TIVOLY NORM				WELDON 19mm	FEIN QUICK-IN	ADAPTADOR FEIN A WELDON ADAPTER FEIN => WELDON	85
	1111131	TIVOLY NORM				WELDON 19mm		ADAPTADORES DE CM A WELDON ARBOR HOLDERS CM => WELDON	86
	1111141	TIVOLY NORM				WELDON 19mm	LUB	ADAPTADORES DE CM A WELDON ARBOR HOLDERS WITH LUBRICATION	86

	1501511	HSS	DIN 352	M		X3 SET	BRIGHT UNCOATED	A	94	
	1501521	HSS	DIN 2181	MF		X2 SET	BRIGHT UNCOATED	A	95	
	1050051	HSS	DIN 352	M		X3 SET	BRIGHT UNCOATED	A	97	
	9501081	HSS	DIN 352	M		X3 SET	BRIGHT UNCOATED	C	A	98
	9501061	HSS	DIN 2181	MF		X2 SET	BRIGHT UNCOATED	C	A	98
	9501031	HSS EE	ISO 529	M		X3 SET	BRIGHT UNCOATED	AB CDE FGH	99	
	9521011	HSS	DIN 352	UNC		X3 SET	BRIGHT UNCOATED	A	100	
	9521021	HSS	DIN 2181	UNF		X2 SET	BRIGHT UNCOATED	A	101	
	9511011	HSS	DIN 352	BSW		X3 SET	BRIGHT UNCOATED	A	102	
	9511021	HSS	DIN 2181	BSF		X2 SET	BRIGHT UNCOATED	A	103	
	9531021	HSS	DIN 5157	BSP G		X2 SET	BRIGHT UNCOATED	A	104	
	9531061	HSS	DIN 5157	BSP G		X2 SET	BRIGHT UNCOATED	C	A	104

TALADRADO
DRILLING































FRESAS HUECAS
CORE HOLE DRILLING

MACHOS & COJINETES
CORE HOLE DRILLING

FRESADO
MILLING

AFILADORES
SHARPENING















































INFORMACIÓN TÉCNICA
TECHNICAL INFORMATION

	9602011	HSS E	DIN 371	MF		C FORM	6H	BRIGHT UNCOATED	A B	106
	9603011	HSS E	DIN 374/376	MF		C FORM	6H	BRIGHT UNCOATED	A B	107
	1602521	HSS E	DIN 371/374 376	MF		GUN B FORM	6H	BRIGHT UNCOATED	A B	108
	1603521	HSS E	DIN 371/374 376	MF		GUN B FORM	6H	BRIGHT UNCOATED	A B	108
	9602221	HSS E	DIN 371/374 376	M		GUN B FORM	6G	BRIGHT UNCOATED	A B	109
	9600021	HSS E	DIN 371/374 376	MF		GUN B FORM	6H	BRIGHT UNCOATED	A B C	109
	1602551	HSS E	DIN 371/374 376	MF		C FORM	6H	BRIGHT UNCOATED	A B 35°	110
	1603551	HSS E	DIN 371/374 376	MF		C FORM	6H	BRIGHT UNCOATED	A B 35°	110
	9602251	HSS E	DIN 371/374 376	MF		C FORM	6G	BRIGHT UNCOATED	A B 35°	111
	9600051	HSS E	DIN 371/374 376	MF		C FORM	6H	BRIGHT UNCOATED	A B 35°	111
	1050081	HSS	DIN 371/376	M		GUN B FORM	6H	BRIGHT UNCOATED	A	112
	1050101	HSS	DIN 371/376	M		C FORM	6H	BRIGHT UNCOATED	A 35°	113
	9704601	HSS E	NFE 66112	M		A FORM	6H	BRIGHT UNCOATED	A B	114
	9704611	HSS E	NFE 66112	M		GUN B FORM	6H	BRIGHT UNCOATED	A B	115
	9622021	HSS E	DIN 371	UNC UNF		GUN B FORM	2B	BRIGHT UNCOATED	A B	116
	9623021	HSS E	DIN 376	UNC UNF		GUN B FORM	2B	BRIGHT UNCOATED	A B	117
	9622051	HSS E	DIN 371	UNC UNF		C FORM	2B	BRIGHT UNCOATED	A B 35°	118
	9623051	HSS E	DIN 376	UNC UNF		C FORM	2B	BRIGHT UNCOATED	A B 35°	119
	9612021	HSS E	DIN 371	BSW		GUN B FORM	BRIGHT UNCOATED	A B	120	
	9613021	HSS E	DIN 376	BSW		GUN B FORM	BRIGHT UNCOATED	A B	120	
	9612051	HSS E	DIN 371	BSW		C FORM	BRIGHT UNCOATED	A B 35°	121	
	9613051	HSS E	DIN 376	BSW		C FORM	BRIGHT UNCOATED	A B 35°	121	

MACHOS DE MÁQUINA | MACHINE TAPS

APLICACIONES













Pág.

	9633011							A B	122	
	9633021							A B	122	
	9633051								A B	123
	9633031								A B	123
	9643101								A	124
	9643011								A	124

**JUEGOS DE MACHOS DE MANO MULTI-APLICACIÓN
MULTI-APPLICATIONS HAND TAPS SET**

APLICACIONES

Pág.

	9501011							AB C H IJ KLM	128
	9501021							AB C H IJ KLM	129
	9531421							AB C H IJ KLM	130

MACHOS DE MÁQUINA MULTI-APLICACIÓN | MULTI-APPLICATIONS MACHINE TAPS

APLICACIONES

Pág.

	9602021							AB C H IJ KLM	132	
	9603021							AB C H IJ KLM	134	
	9602051								AB C H IJ KLM	136
	9603051								AB C H IJ KLM	137
	9633421							AB C H IJ KLM	138	
	9633451								AB C H IJ KLM	139
	9605821							F G H	140	
	9606821							F G H	141	
	9605851								F G H	142
	9606851								F G H	143

TALADRADO
DRILLING





























































































































FRESAS HUECAS
CORE HOLE DRILLING

MACHOS & COJINETES
CORE HOLE DRILLING

FRESADO
MILLING

AFILADORES
SHARPENING



INFORMACIÓN TÉCNICA
TECHNICAL INFORMATION

	960ST21								A B C	146
	960ST51							A B C	147	
	960SRH1							A B C	148	
	962ST21								A B C	149
	962ST51							A B C	150	
	960IT21								CDE FGH ARCo ARNi Ti	151
	960IT51							CDE FGH ARCo ARNi Ti	152	
	960IRH1							CDE FGH ARCo ARNi	153	
	962IT21								CDE FGH ARCo ARNi Ti	154
	962IT51							CDE FGH ARCo ARNi Ti	155	
	960AT21								K L M	156
	960AT51							K L M	157	
	960GSH1							K L M	158	
	962AT21								K L M	159
	962AT51							K L M	160	
	960BT11							N O	161	
	962BT11							N O	162	

MACHOS DE MÁQUINA FLASH-CUT | FLASH-CUT MACHINE TAPS

APLICACIONES









































Pág.

	963BT11							N O	163
	960CT11							I J	164
	962CT11							I J	165
	963CT11							I J	166

COJINETES | DIES

APLICACIONES

Pág.

	1100411							AB C H	168
	11004170007								168
	1100441							AB C H	169
	1100471							A B	170
	1100481							A B	171
	1100501							A B	172
	1100491							A B	173

ACCESORIOS | ACCESSORIES

APLICACIONES

Pág.

	1110011		GIRAMACHOS TAP WRENCH	174
	1110031		PORTAMACHOS REVERSIBLE CON TRINQUETE TAP WRENCH WITH RATCHET	174
	120968		JUEGO DE EXTRACTORES DE TORNILLOS ROTOS BROKEN PIN REMOVER SET	176
	1110041		PORTA COJINETES ACERO DIE HOLDER STEEL BODY AND HANDLE	175
	1110051		ALARGADOR DE PORTA COJINETES ACERO END DIE HOLDER STEEL BODY	175

TALADRADO
DRILLING

FRESAS HUECAS
CORE HOLE DRILLING

MACHOS & COJINETES
CORE HOLE DRILLING

FRESADO
MILLING

AFILADORES
SHARPENING

INFORMACIÓN TÉCNICA
TECHNICAL INFORMATION



16025270003 ➤ **A** 178

16025570003 ➤ **A** 178

96020270003 ➤ **AB C H IJ KLM** 178

96020570003 ➤ **AB C H IJ KLM** 178

960ST270003 ➤ **A B C** 179

960ST570003 ➤ **A B C** 179

960IT270003 ➤ **CDE FGH ARCo ARNi Ti** 179

960IT570003 ➤ **CDE FGH ARCo ARNi Ti** 179

80511670001 ➤ **AB** 180

11900870001 ➤ **AB** 180

1602527 ➤ **AB** 181

1602557 ➤ **AB** 181

9602027 ➤ **AB C H IJ KLM** 181

9602057 ➤ **AB C H IJ KLM** 181



ESTUCHES DE MACHOS Y BROCAS PREVIAS |
TAPS & PREVIOUS DRILL SETS

APLICACIONES

Pág.



960ST27											182			
960ST57											182			
960IT27											182			
960IT57											182			
1602507											183			
1602517														183
960ST07												183		
960IT07												183		

AVELLANADORES | COUNTERSINKERS

APLICACIONES

Pág.



1033161								186
----------------	--	--	--	--	--	--	--	-----



1036631									187
----------------	--	--	--	--	--	--	--	--	-----



10331670005								188
--------------------	--	--	--	--	--	--	--	-----



10331670002								188
--------------------	--	--	--	--	--	--	--	-----



10336370001									188
--------------------	--	--	--	--	--	--	--	--	-----



10310370002								188
--------------------	--	--	--	--	--	--	--	-----

FRESAS LIMA | ROTARY BURRS

APLICACIONES

Pág.



1031601								189
----------------	--	--	--	--	--	--	--	-----



1031611									189
----------------	--	--	--	--	--	--	--	--	-----

TALADRADO
DRILLING

FRESAS HUECAS
CORE HOLE DRILLING

MACHOS & COJINETES
CORE HOLE DRILLING

FRESADO
MILLING

AFILADORES
SHARPENING

INFORMACIÓN TÉCNICA
TECHNICAL INFORMATION

	1031621								190	
	1037161								190	
	1031631									191
	1036651									191
	1031641									192
	1037171									192
	1031651									193
	1036681									193
	1031701									194
	1031711									194
	1031721									195
	1031741									195
	1031761									196
	1031771									196
	1036701									197
	1031781									197
	1037181									198
	1031791									198

FRESAS LIMA | ROTARY BURRS

APLICACIONES

Pág.

	1031801							199	
	1031811								199
	1031821							200	
	1037191							200	
	1031831							201	
	1036671							201	
	1031841							202	
	1037201							202	
	1031851							203	
	1036691							203	
	10316070008							204	
	10316070002							204	

FRESAS FRONTALES | END MILLS

APLICACIONES

Pág.

	8030881									205		
	8030031											206
	8037131											207
	8030111											208
	8037141											209
	8030191											210
	8037151											211

	1111177750M ➤ DD 750	DRILL DOCTOR 750 DRILL DOCTOR 750	214
	1111177500M ➤ DD 500	DRILL DOCTOR 500 DRILL DOCTOR 500	214
	1111177400B ➤ DD 400	DRILL DOCTOR 400 DRILL DOCTOR 400	214
	11111720004 ➤ M 100	MUELA PARA DRILL DOCTOR DRILL DOCTOR GRINDER	215
	11111720001 ➤ M 180	MUELA PARA DRILL DOCTOR DRILL DOCTOR GRINDER	215
	11111720002 ➤ 2.5-19 mm	PORTABROCAS PARA DRILL DOCTOR DRILL DOCTOR CHUCK	215

INFORMACIÓN TÉCNICA TECHNICAL INFORMATION	➤	218
CONDICIONES DE CORTE ROSCADO CUTTING CONDITIONS TAPPING	➤	219
CONDICIONES DE CORTE BROCAS CUTTING CONDITIONS DRILLS	➤	224
CONDICIONES DE CORTE MACHOS CUTTING CONDITIONS TAPS	➤	226
CONDICIONES DE CORTE FRESAS LIMAS CUTTING CONDITIONS ROTARY BURRS	➤	228
CONDICIONES DE CORTE FRESADO CUTTING CONDITIONS END MILLING	➤	228
CONDICIONES DE VENTA CONDITIONS OF SALE	➤	234





- **BROCAS ACERO RÁPIDO** 24
HSS BITS
- **BROCAS METAL DURO** 70
CARBIDE BITS

BROCA HSS SERIE EXTRA-CORTA DIN1897 | TALADRADOS POCO PROFUNDOS <2xd | APLICACIÓN: ACEROS BLANDOS HASTA 400 N/mm²

HSS DRILL EXTRA-SHORT SERIE DIN 1897 | LITTLE DEEP DRILLING <2xd | SOFT STEELS UP TO 400 N/mm²

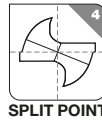
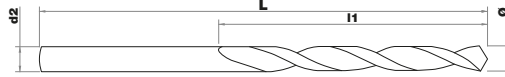

Aceros débilmente aleados <400 N/mm²
Low alloyed steels <400N/mm²

1140261	Ø	d2	L	l1	QTY	PCB	€
11402610100	1	1	26	6	1	10	2,05
11402610150	1,5	1,5	32	9	1	10	1,82
11402610180	1,8	1,8	36	11	1	10	2,44
11402610200	2	2	38	12	1	10	0,92
11402610220	2,2	2,2	40	13	1	10	1,15
11402610250	2,5	2,5	43	14	1	10	0,92
11402610280	2,8	2,8	46	16	1	10	1,18
11402610300	3	3	46	16	1	10	0,97
11402610320	3,2	3,2	49	18	1	10	1,28
11402610325	3,25	3,25	49	18	1	10	1,04
11402610330	3,3	3,3	49	18	1	10	1,28
11402610350	3,5	3,5	52	20	1	10	1,04
11402610375	3,75	3,75	52	20	1	10	1,15
11402610380	3,8	3,8	55	22	1	10	1,38
11402610400	4	4	55	22	1	10	1,15
11402610410	4,1	4,1	55	22	1	10	1,37
11402610420	4,2	4,2	55	22	1	10	1,37
11402610425	4,25	4,25	55	22	1	10	1,37
11402610450	4,5	4,5	58	24	1	10	1,38
11402610480	4,8	4,8	62	26	1	10	1,87
11402610500	5	5	62	26	1	10	1,56
11402610510	5,1	5,1	62	26	1	10	2,06
11402610520	5,2	5,2	62	26	1	10	2,06
11402610525	5,25	5,25	62	26	1	10	1,69
11402610550	5,5	5,5	66	28	1	10	1,69
11402610575	5,75	5,75	66	28	1	10	1,96
11402610580	5,8	5,8	66	28	1	10	2,31
11402610600	6	6	66	28	1	10	1,96
11402610650	6,5	6,5	70	31	1	10	2,30
11402610675	6,75	6,75	74	34	1	10	2,72
11402610680	6,8	6,8	74	34	1	10	2,72
11402610700	7	7	74	34	1	10	2,72
11402610750	7,5	7,5	74	34	1	10	3,04
11402610800	8	8	79	37	1	10	3,35
11402610825	8,25	8,25	79	37	1	5	3,97
11402610850	8,5	8,5	79	37	1	5	3,97
11402610900	9	9	84	40	1	5	4,35
11402610950	9,5	9,5	84	40	1	5	4,87
11402611000	10	10	89	43	1	5	5,44
11402611050	10,5	10,5	89	43	1	5	6,13
11402611100	11	11	95	47	1	5	6,85
11402611150	11,5	11,5	95	47	1	5	7,61
11402611200	12	12	102	51	1	5	8,04
11402611250	12,5	12,5	102	51	1	5	9,01
11402611300	13	13	102	51	1	5	9,85



**BROCA ACERO COBALTO 5% (HSSE5) SERIE EXTRA-CORTA
DIN1897 | TALADRADOS POCO PROFUNDOS <2xd | APLICACIÓN:
ACEROS SEMI-DUROS HASTA 700 N/mm², INOXIDABLES**

COBALT DRILL 5% (HSSE5) EXTRA-SHORT SERIE DIN1897 | LITTLE DEEP
DRILLING <2xd | SEMI-HARD STEELS UP TO 700 N/mm² AND STAINLESS STEELS

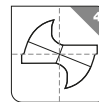
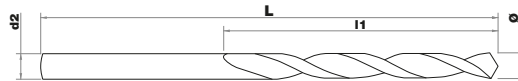

Aceros aleados
200-700 N/mm²
Alloyed steels
200-700N/mm²



Aceros
inoxidables
ferríticos
Ferritic
stainless
steels

1140281	Ø	d3	L	l2	QTY	PCB	€
11402810200	2	2	38	12	1	10	1,08
11402810220	2,2	2,2	40	13	1	10	1,63
11402810250	2,5	2,5	43	14	1	10	1,59
11402810275	2,75	2,75	46	16	1	10	1,66
11402810300	3	3	46	16	1	10	1,65
11402810320	3,2	3,2	49	18	1	10	1,79
11402810325	3,25	3,25	49	18	1	10	1,69
11402810330	3,3	3,3	49	18	1	10	1,83
11402810350	3,5	3,5	52	20	1	10	1,76
11402810375	3,75	3,75	52	20	1	10	1,93
11402810400	4	4	55	22	1	10	1,96
11402810410	4,1	4,1	55	22	1	10	2,27
11402810420	4,2	4,2	55	22	1	10	2,27
11402810425	4,25	4,25	55	22	1	10	2,17
11402810450	4,5	4,5	58	24	1	10	2,24
11402810490	4,9	4,9	62	26	1	10	2,36
11402810500	5	5	62	26	1	10	2,53
11402810525	5,25	5,25	62	26	1	10	2,44
11402810550	5,5	5,5	66	28	1	10	2,61
11402810600	6	6	66	28	1	10	2,84
11402810650	6,5	6,5	70	31	1	10	3,31
11402810680	6,8	6,8	74	34	1	10	4,44
11402810700	7	7	74	34	1	10	3,63
11402810750	7,5	7,5	74	34	1	10	4,65
11402810800	8	8	79	37	1	10	5,13
11402810850	8,5	8,5	79	37	1	5	5,53
11402810900	9	9	84	40	1	5	6,29
11402810950	9,5	9,5	84	40	1	5	6,62
11402811000	10	10	89	43	1	5	7,36



BROCA HSS DOBLE PUNTA DIN 1897 | TALADRADOS POCO PROFUNDOS <1xd | APLICACIÓN: ACEROS SEMI-DUROS HASTA 700 N/mm²

HSS DRILL DOUBLE ENDED DIN 1897 | LITTLE DEEP <1xd |
APLICATTION: SEMI-HARD SEELS UP TO 700 N/mm²

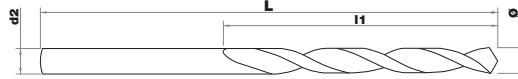

Aceros aleados
200-700 N/mm²
Alloyed steels
200-700N/mm²

1140271	Ø	d2	L	l1	QTY	PCB	€
11402710200	2	2	38	10	1	1	6,53
11402710220	2,2	2,2	40	10	1	1	6,22
11402710250	2,5	2,5	43	10	1	1	3,76
11402710300	3	3	46	10	1	1	3,32
11402710310	3,1	3,1	49	10	1	1	5,44
11402710320	3,2	3,2	49	10	1	1	3,47
11402710330	3,3	3,3	49	10	1	1	3,47
11402710350	3,5	3,5	52	13	1	1	3,71
11402710380	3,8	3,8	55	13	1	1	6,53
11402710400	4	4	55	13	1	1	3,76
11402710410	4,1	4,1	55	13	1	1	3,79
11402710420	4,2	4,2	55	13	1	1	3,79
11402710450	4,5	4,5	58	13	1	1	4,20
11402710480	4,8	4,8	62	16	1	1	9,67
11402710490	4,9	4,9	62	16	1	1	7,16
11402710500	5	5	62	16	1	1	4,78
11402710510	5,1	5,1	62	16	1	1	6,78
11402710520	5,2	5,2	62	16	1	1	6,78
11402710550	5,5	5,5	66	19	1	1	9,97
11402710600	6	6	66	19	1	1	6,44
11402710650	6,5	6,5	70	19	1	1	12,32
11402710700	7	7	74	19	1	1	14,63
11402710800	8	8	79	22	1	1	10,39
11402710900	9	9	84	22	1	1	19,05
11402711000	10	10	89	22	1	1	20,36



BROCA HSS PARA PUNTOS DE SOLDADURA SERIE EXTRA-CORTA DIN 1897 | APLICACIÓN: CHAPAS Y PLÁSTICOS

HSS STUB LENGTH DRILL DIN 1897 | APLICATTION: SHEET METAL
AND PLASTICS

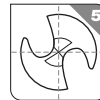
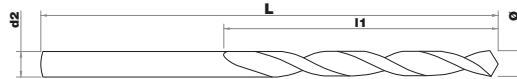

Aceros aleados
200-700 N/mm²
Alloyed steels
200-700N/mm²



Plásticos
Plastics

1143741	Ø	d2	L	l1	QTY	PCB	€
11437410300	3	3	46	16	1	10	2,22
11437410350	3,5	3,5	52	20	1	10	2,62
11437410400	4	4	55	22	1	10	2,92
11437410420	4,2	4,2	55	22	1	10	3,24
11437410450	4,5	4,5	58	24	1	10	3,33
11437410500	5	5	62	26	1	10	3,57
11437410550	5,5	5,5	66	28	1	10	4,71
11437410600	6	6	66	28	1	10	4,82
11437410800	8	8	79	37	1	10	8,27
11437411000	10	10	89	43	1	5	12,87

BROCA ACERO COBALTO 5% (HSSE5) TIALN | SERIE EXTRA-CORTA DIN1897 | HÉLICE TIPO "S" | TALADRADOS POCO PROFUNDOS <2xd |

COBALT DRILL 5% (HSSE5) TiAlN | EXTRA-SHORT SERIE DIN 1897 | TYPE "S" HELIX | LITTLE DEEP DRILLING < 2xd

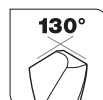
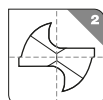
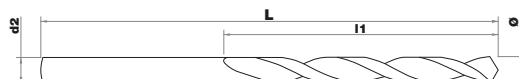
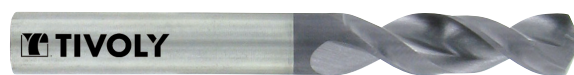

Aceros aleados
200-700 N/mm²
Alloyed steels
200-700N/mm²



Aceros aleados
y tratados
< 1200N/mm²
Heat Treatable
Steels
<1200N/mm²



Aceros
inoxidables
Stainless
Steels



Fundición
nodular
SG iron



Aleaciones
de aluminio
Si>10%
Aluminium
alloys
Si>10%

8143911	Ø	d2	L	l1	QTY	PCB	€
81439110200	2	2	38	12	1	10	10,64
81439110210	2,1	2,1	38	12	1	10	10,05
81439110220	2,2	2,2	40	13	1	10	10,27
81439110230	2,3	2,3	40	13	1	10	10,49
81439110240	2,4	2,4	43	14	1	10	10,89
81439110250	2,5	2,5	43	14	1	10	10,79
81439110260	2,6	2,6	43	14	1	10	10,79
81439110270	2,7	2,7	46	16	1	10	10,98
81439110280	2,8	2,8	46	16	1	10	11,12
81439110290	2,9	2,9	46	16	1	10	11,18
81439110300	3	3	46	16	1	10	11,23
81439110310	3,1	3,1	49	18	1	10	11,26
81439110320	3,2	3,2	49	18	1	10	10,93
81439110330	3,3	3,3	49	18	1	10	11,91
81439110340	3,4	3,4	52	20	1	10	11,72
81439110350	3,5	3,5	52	20	1	10	12,25
81439110360	3,6	3,6	52	20	1	10	11,94
81439110370	3,7	3,7	52	20	1	10	11,94
81439110380	3,8	3,8	55	22	1	10	12,16
81439110390	3,9	3,9	55	22	1	10	12,18
81439110400	4	4	55	22	1	10	12,74
81439110410	4,1	4,1	55	22	1	10	12,74
81439110420	4,2	4,2	55	22	1	10	12,74
81439110430	4,3	4,3	58	24	1	10	13,38
81439110440	4,4	4,4	58	24	1	10	13,59
81439110450	4,5	4,5	58	24	1	10	13,76
81439110460	4,6	4,6	58	24	1	10	13,76
81439110470	4,7	4,7	58	24	1	10	13,76
81439110480	4,8	4,8	62	26	1	10	14,03
81439110490	4,9	4,9	62	26	1	10	14,22
81439110500	5	5	62	26	1	10	14,38
81439110510	5,1	5,1	62	26	1	10	14,60
81439110520	5,2	5,2	62	26	1	10	15,14
81439110530	5,3	5,3	62	26	1	10	15,50
81439110540	5,4	5,4	66	28	1	10	16,75
81439110550	5,5	5,5	66	28	1	10	16,79
81439110560	5,6	5,6	66	28	1	10	17,03
81439110570	5,7	5,7	66	28	1	10	17,03
81439110580	5,8	5,8	66	28	1	10	17,22
81439110590	5,9	5,9	66	28	1	10	17,22
81439110600	6	6	66	28	1	10	16,79
81439110610	6,1	6,1	70	31	1	10	23,48
81439110620	6,2	6,2	70	31	1	10	23,66
81439110630	6,3	6,3	70	31	1	10	23,84
81439110640	6,4	6,4	70	31	1	10	25,19
81439110650	6,5	6,5	70	31	1	10	24,33
81439110660	6,6	6,6	70	31	1	10	25,37
81439110670	6,7	6,7	70	31	1	10	25,59
81439110680	6,8	6,8	74	34	1	10	26,09
81439110690	6,9	6,9	74	34	1	10	26,26
81439110700	7	7	74	34	1	10	24,57
81439110710	7,1	7,1	74	34	1	10	29,53
81439110720	7,2	7,2	74	34	1	10	31,62
81439110730	7,3	7,3	74	34	1	10	30,03
81439110740	7,4	7,4	74	34	1	10	30,37
81439110750	7,5	7,5	74	34	1	10	25,85
81439110760	7,6	7,6	79	37	1	10	30,97

8143911	Ø	d2	L	I1	QTY	PCB	€
81439110770	7,7	7,7	79	37	1	10	30,97
81439110780	7,8	7,8	79	37	1	10	33,92
81439110790	7,9	7,9	79	37	1	10	33,25
81439110800	8	8	79	37	1	10	27,61
81439110810	8,1	8,1	79	37	1	5	33,65
81439110820	8,2	8,2	79	37	1	5	38,97
81439110830	8,3	8,3	79	37	1	5	34,88
81439110840	8,4	8,4	79	37	1	5	35,93
81439110850	8,5	8,5	79	37	1	5	32,33
81439110860	8,6	8,6	84	40	1	5	37,71
81439110870	8,7	8,7	84	40	1	5	37,71
81439110880	8,8	8,8	84	40	1	5	42,85
81439110890	8,9	8,9	84	40	1	5	40,09
81439110900	9	9	84	40	1	5	34,90
81439110910	9,1	9,1	84	40	1	5	38,84
81439110920	9,2	9,2	84	40	1	5	39,89
81439110930	9,3	9,3	84	40	1	5	39,89
81439110940	9,4	9,4	84	40	1	5	40,23
81439110950	9,5	9,5	84	40	1	5	36,87
81439110960	9,6	9,6	89	43	1	5	41,24
81439110970	9,7	9,7	89	43	1	5	42,31
81439110980	9,8	9,8	89	43	1	5	43,02
81439110990	9,9	9,9	89	43	1	5	44,10
81439111000	10	10	89	43	1	5	36,50
81439111010	10,1	10,1	89	43	1	5	44,93
81439111020	10,2	10,2	89	43	1	5	44,93
81439111030	10,3	10,3	89	43	1	5	44,93
81439111040	10,4	10,4	89	43	1	5	44,93
81439111050	10,5	10,5	89	43	1	5	53,95
81439111060	10,6	10,6	89	43	1	5	52,42
81439111070	10,7	10,7	95	47	1	5	52,42
81439111080	10,8	10,8	95	47	1	5	61,40
81439111090	10,9	10,9	95	47	1	5	52,42
81439111100	11	11	95	47	1	5	53,95
81439111110	11,1	11,1	95	47	1	5	60,71
81439111120	11,2	11,2	95	47	1	5	65,88
81439111130	11,3	11,3	95	47	1	5	66,94
81439111140	11,4	11,4	95	47	1	5	60,71
81439111150	11,5	11,5	95	47	1	5	59,47
81439111160	11,6	11,6	95	47	1	5	60,71
81439111170	11,7	11,7	95	47	1	5	60,71
81439111180	11,8	11,8	95	47	1	5	67,65
81439111190	11,9	11,9	102	51	1	5	60,71
81439111200	12	12	102	51	1	5	59,47
81439111210	12,1	12,1	102	51	1	5	72,64
81439111220	12,2	12,2	102	51	1	5	72,64
81439111230	12,3	12,3	102	51	1	5	72,64
81439111240	12,4	12,4	102	51	1	5	72,52
81439111250	12,5	12,5	102	51	1	5	67,49
81439111260	12,6	12,6	102	51	1	5	69,51
81439111270	12,7	12,7	102	51	1	5	69,51
81439111280	12,8	12,8	102	51	1	5	69,51
81439111290	12,9	12,9	102	51	1	5	69,51
81439111300	13	13	102	51	1	5	74,23
81439111350	13,5	13,5	107	54	1	5	77,46
81439111400	14	14	107	54	1	5	78,65
81439111450	14,5	14,5	111	56	1	5	93,33
81439111500	15	15	111	56	1	5	92,97
81439111550	15,5	15,5	115	58	1	1	102,23
81439111600	16	16	115	58	1	1	97,32
81439111650	16,5	16,5	119	60	1	1	106,55
81439111700	17	17	119	60	1	1	107,47
81439111750	17,5	17,5	123	62	1	1	109,48
81439111800	18	18	123	62	1	1	110,63
81439111850	18,5	18,5	127	64	1	1	114,43
81439111900	19	19	127	64	1	1	115,89
81439111950	19,5	19,5	131	66	1	1	118,78
81439112000	20	20	131	66	1	1	120,23

BROCA HSS SERIE CORTA DIN 338 | TALADRADOS DE PROFUNDIDAD MEDIA <3xd | APLICACIÓN: ACEROS BLANDOS HASTA 400 N/mm²

HSS DRILL SHORT SERIE DIN 338 | NORMAL DEEP DRILLING <3xd |
APPLICATION: SOFT STEELS UP TO 400 N/mm²

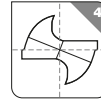
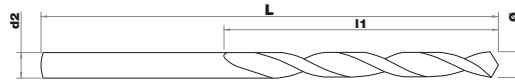

SPLIT POINT



Aceros débilmente aleados <400 N/mm²
Low alloyed steels <400N/mm²

1145301	Ø	d2	L	I1	QTY	PCB	€
11453010020	0,2	0,2	19	2,5	1	10	6,18
11453010025	0,25	0,25	19	3	1	10	3,61
11453010030	0,3	0,3	19	3	1	10	3,62
11453010035	0,35	0,35	19	4	1	10	3,22
11453010040	0,4	0,4	20	5	1	10	3,22
11453010045	0,45	0,45	20	5	1	10	2,63
11453010050	0,5	0,5	22	6	1	10	2,21
11453010055	0,55	0,55	24	7	1	10	2,30
11453010060	0,6	0,6	24	7	1	10	2,30
11453010065	0,65	0,65	26	8	1	10	1,89
11453010070	0,7	0,7	28	9	1	10	1,89
11453010075	0,75	0,75	29	9	1	10	1,73
11453010080	0,8	0,8	30	10	1	10	1,74
11453010085	0,85	0,85	30	10	1	10	1,63
11453010090	0,9	0,9	32	11	1	10	1,63
11453010095	0,95	0,95	32	11	1	10	1,63
11453010100	1	1	34	12	1	10	1,41
11453010105	1,05	1,05	34	12	1	10	1,41
11453010110	1,1	1,1	36	14	1	10	1,35
11453010120	1,2	1,2	38	14	1	10	1,58
11453010125	1,25	1,25	38	16	1	10	1,16
11453010130	1,3	1,3	38	16	1	10	1,31
11453010140	1,4	1,4	40	18	1	10	1,35
11453010150	1,5	1,5	40	18	1	10	1,10
11453010160	1,6	1,6	43	20	1	10	1,19
11453010170	1,7	1,7	43	20	1	10	1,35
11453010175	1,75	1,75	46	22	1	10	1,11
11453010180	1,8	1,8	46	22	1	10	1,12
11453010190	1,9	1,9	46	22	1	10	1,11
11453010200	2	2	49	24	1	10	0,92
11453010210	2,1	2,1	49	24	1	10	1,11
11453010220	2,2	2,2	53	27	1	10	1,11
11453010225	2,25	2,25	53	27	1	10	1,11
11453010230	2,3	2,3	53	27	1	10	1,11
11453010240	2,4	2,4	57	30	1	10	1,23
11453010250	2,5	2,5	57	30	1	10	1,15
11453010260	2,6	2,6	57	30	1	10	1,23
11453010270	2,7	2,7	61	33	1	10	1,23
11453010275	2,75	2,75	61	33	1	10	1,22
11453010280	2,8	2,8	61	33	1	10	1,23
11453010290	2,9	2,9	61	33	1	10	1,23
11453010300	3	3	61	33	1	10	0,98
11453010310	3,1	3,1	65	36	1	10	1,23

1145301	Ø	d2	L	I1	QTY	PCB	€
11453010320	3,2	3,2	65	36	1	10	1,20
11453010325	3,25	3,25	65	36	1	10	1,22
11453010330	3,3	3,3	65	36	1	10	1,38
11453010340	3,4	3,4	70	39	1	10	1,38
11453010350	3,5	3,5	70	39	1	10	1,19
11453010360	3,6	3,6	70	39	1	10	1,38
11453010370	3,7	3,7	70	39	1	10	1,38
11453010375	3,75	3,75	70	39	1	10	1,35
11453010380	3,8	3,8	75	43	1	10	1,54
11453010390	3,9	3,9	75	43	1	10	1,54
11453010400	4	4	75	43	1	10	1,31
11453010410	4,1	4,1	75	43	1	10	1,54
11453010420	4,2	4,2	75	43	1	10	1,54
11453010425	4,25	4,25	75	43	1	10	1,48
11453010430	4,3	4,3	80	47	1	10	1,68
11453010440	4,4	4,4	80	47	1	10	1,68
11453010450	4,5	4,5	80	47	1	10	1,51
11453010460	4,6	4,6	80	47	1	10	1,68
11453010470	4,7	4,7	80	47	1	10	1,78
11453010475	4,75	4,75	80	47	1	10	1,96
11453010480	4,8	4,8	86	52	1	10	1,78
11453010490	4,9	4,9	86	52	1	10	1,82
11453010500	5	5	86	52	1	10	1,57
11453010510	5,1	5,1	86	52	1	10	1,93
11453010520	5,2	5,2	86	52	1	10	1,93
11453010525	5,25	5,25	86	52	1	10	1,96
11453010530	5,3	5,3	86	52	1	10	1,93
11453010540	5,4	5,4	93	57	1	10	2,24
11453010550	5,5	5,5	93	57	1	10	2,11
11453010560	5,6	5,6	93	57	1	10	2,27
11453010570	5,7	5,7	93	57	1	10	2,30
11453010575	5,75	5,75	93	57	1	10	2,30
11453010580	5,8	5,8	93	57	1	10	2,35
11453010590	5,9	5,9	93	57	1	10	2,42
11453010600	6	6	93	57	1	10	2,17
11453010610	6,1	6,1	101	63	1	10	2,64
11453010620	6,2	6,2	101	63	1	10	2,64
11453010625	6,25	6,25	101	63	1	10	3,13
11453010630	6,3	6,3	101	63	1	10	2,67
11453010640	6,4	6,4	101	63	1	10	2,76
11453010650	6,5	6,5	101	63	1	10	2,56
11453010660	6,6	6,6	101	63	1	10	2,85
11453010670	6,7	6,7	101	63	1	10	2,88
11453010675	6,75	6,75	109	69	1	10	3,50
11453010680	6,8	6,8	109	69	1	10	3,62
11453010690	6,9	6,9	109	69	1	10	3,55
11453010700	7	7	109	69	1	10	3,10
11453010710	7,1	7,1	109	69	1	10	3,62
11453010720	7,2	7,2	109	69	1	10	3,70
11453010725	7,25	7,25	109	69	1	10	3,70
11453010730	7,3	7,3	109	69	1	10	3,70
11453010740	7,4	7,4	109	69	1	10	3,74
11453010750	7,5	7,5	109	69	1	10	3,24
11453010760	7,6	7,6	117	75	1	10	4,10
11453010770	7,7	7,7	117	75	1	10	4,10
11453010775	7,75	7,75	117	75	1	10	4,14
11453010780	7,8	7,8	117	75	1	10	4,15
11453010790	7,9	7,9	117	75	1	10	4,22
11453010800	8	8	117	75	1	10	3,70
11453010810	8,1	8,1	117	75	1	5	4,31
11453010820	8,2	8,2	117	75	1	5	4,42
11453010825	8,25	8,25	117	75	1	5	4,42
11453010830	8,3	8,3	117	75	1	5	4,39
11453010840	8,4	8,4	117	75	1	5	4,59
11453010850	8,5	8,5	117	75	1	5	4,02
11453010860	8,6	8,6	125	81	1	5	5,34
11453010870	8,7	8,7	125	81	1	5	5,34
11453010875	8,75	8,75	125	81	1	5	5,34
11453010880	8,8	8,8	125	81	1	5	5,34
11453010890	8,9	8,9	125	81	1	5	5,46
11453010900	9	9	125	81	1	5	4,87
11453010910	9,1	9,1	125	81	1	5	5,46



1145301	Ø	d2	L	I1	QTY	PCB	€
11453010920	9,2	9,2	125	81	1	5	5,46
11453010925	9,25	9,25	125	81	1	5	5,75
11453010930	9,3	9,3	125	81	1	5	5,75
11453010940	9,4	9,4	125	81	1	5	5,75
11453010950	9,5	9,5	125	81	1	5	5,29
11453010960	9,6	9,6	133	87	1	5	6,00
11453010970	9,7	9,7	133	87	1	5	6,00
11453010975	9,75	9,75	133	87	1	5	6,32
11453010980	9,8	9,8	133	87	1	5	6,33
11453010990	9,9	9,9	133	87	1	5	6,33
11453011000	10	10	133	87	1	5	5,73
11453011010	10,1	10,1	133	87	1	5	7,25
11453011020	10,2	10,2	133	87	1	5	7,25
11453011025	10,25	10,25	133	87	1	5	7,85
11453011030	10,3	10,3	133	87	1	5	8,43
11453011040	10,4	10,4	133	87	1	5	8,43
11453011050	10,5	10,5	133	87	1	5	7,38
11453011060	10,6	10,6	133	87	1	5	8,62
11453011070	10,7	10,7	142	94	1	5	10,66
11453011075	10,75	10,75	142	94	1	5	9,95
11453011080	10,8	10,8	142	94	1	5	10,66
11453011090	10,9	10,9	142	94	1	5	10,66
11453011100	11	11	142	94	1	5	8,62
11453011110	11,1	11,1	142	94	1	5	11,09
11453011120	11,2	11,2	142	94	1	5	10,66
11453011125	11,25	11,25	142	94	1	5	10,65
11453011130	11,3	11,3	142	94	1	5	10,66
11453011140	11,4	11,4	142	94	1	5	10,66
11453011150	11,5	11,5	142	94	1	5	9,23
11453011160	11,6	11,6	142	94	1	5	10,66
11453011170	11,7	11,7	142	94	1	5	10,66
11453011175	11,75	11,75	142	94	1	5	10,65
11453011180	11,8	11,8	151	101	1	5	10,66
11453011190	11,9	11,9	151	101	1	5	12,76
11453011200	12	12	151	101	1	5	10,27
11453011210	12,1	12,1	151	101	1	5	13,52
11453011220	12,2	12,2	151	101	1	5	13,75
11453011225	12,25	12,25	151	101	1	5	12,32
11453011230	12,3	12,3	151	101	1	5	11,69
11453011240	12,4	12,4	151	101	1	5	13,93
11453011250	12,5	12,5	151	101	1	5	11,29
11453011260	12,6	12,6	151	101	1	5	13,93
11453011270	12,7	12,7	151	101	1	5	12,72
11453011275	12,75	12,75	151	101	1	5	12,47
11453011280	12,8	12,8	151	101	1	5	13,93
11453011290	12,9	12,9	151	101	1	5	15,81
11453011300	13	13	151	101	1	5	11,69
11453011350	13,5	12	160	108	1	1	17,99
11453011400	14	12	160	108	1	1	19,13
11453011450	14,5	12	169	114	1	1	20,39
11453011500	15	12	169	114	1	1	20,62
11453011550	15,5	12	178	120	1	1	23,80
11453011600	16	12	178	120	1	1	24,62
11453011650	16,5	12	184	125	1	1	27,58
11453011700	17	12	184	125	1	1	27,58
11453011750	17,5	12	191	130	1	1	31,42
11453011800	18	12	191	130	1	1	33,10
11453011850	18,5	12	198	135	1	1	36,50
11453011900	19	12	198	135	1	1	36,50
11453011950	19,5	12	205	140	1	1	39,75
11453012000	20	12	205	140	1	1	45,83
11453012100	21	12	205	145	1	1	52,60
11453012200	22	12	210	150	1	1	60,19
11453012300	23	12	210	150	1	1	61,52
11453012400	24	12	220	160	1	1	62,79
11453012500	25	12	220	160	1	1	78,94

**ESTUCHE DE BROCAS HSS DIN 338 |
DE Ø 1>10 x 0,5 mm**
HSS DRILL SET DIN 338 Ø 1>10 x 0,5 mm

19 PCS
HSS
STEAM TREATED
DIN 338
SPLIT POINT
118°

11453070015		
QTY	PCB	€
19	1	72,80



**ESTUCHE DE BROCAS HSS DIN 338 |
DE Ø 1>13 x 0,5 mm**
HSS DRILL SET DIN 338 | Ø 1>13 x 0,5 mm

25 PCS
HSS
STEAM TREATED
DIN 338
SPLIT POINT
118°

11453070017		
QTY	PCB	€
25	1	129,37



**MALETÍN DE 170 BROCAS HSS DIN 338 |
DE Ø 1>10 x 0,5 mm (Ø1>8x10pzs.)
(Ø8,5>10x5pzs.)**
HSS DRILL CASE DIN 338 | Ø 1>10 x 0,5 mm
(Ø1>8x10pzs.) (Ø8,5>10x5pzs.)

170 PCS
HSS
STEAM TREATED
DIN 338
SPLIT POINT
118°

11453070024		
QTY	PCB	€
170	1	399,94



**MALETÍN DE 222 BROCAS HSS DIN 338 |
DE Ø 1>13 x 0,5 mm+3,3+4,20 (Ø4y5x20pzs.)
(Ø1>8x10pzs.) (Ø8,5>10x5pzs.) (Ø10,5>13x2pzs.)**
HSS DRILL CASE DIN 338 | DE Ø 1>13 x 0,5 mm+3,3+4,20
(Ø4y5x20pzs.) (Ø1>8x10pzs.) (Ø8,5>10x5pzs.)
(Ø10,5>13x2pzs.)

222 PCS
HSS
STEAM TREATED
DIN 338
SPLIT POINT
118°

11453070026		
QTY	PCB	€
222	1	593,20





BROCA HSS SERIE CORTA DIN 338 | MANGO REDUCIDO | TALADRADOS DE PROFUNDIDAD MEDIA < 3xd | APLICACIÓN: ACEROS BLANDOS HASTA 400 N/mm²

HSS DRILL SHORT SERIE DIN 338 | REDUCED SHANK | MEDIUM DEEP DRILLING <3xd | APPLICATION: SOFT STEELS UP TO 400 N/mm²

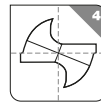
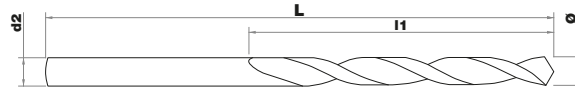

SPLIT POINT



Aceros débilmente aleados <400 N/mm²
Low alloyed steels <400N/mm²

1143784	Ø	d2	L	l	QTY	PCB	€
11437841200	12	10	151	101	1	1	9,45
11437841250	12.5	10	151	101	1	1	10,24
11437841300	13	12,7	151	101	1	1	11,19
11437841350	13.5	12,7	160	108	1	1	13,80
11437841400	14	12,7	160	108	1	1	14,05
11437841450	14.5	12,7	169	114	1	1	15,71
11437841500	15	12,7	169	114	1	1	16,11
11437841550	15.5	12,7	178	120	1	1	18,10
11437841600	16	12,7	178	120	1	1	18,96
11437841650	16.5	12,7	184	125	1	1	22,59
11437841700	17	12,7	184	125	1	1	23,27
11437841750	17.5	12,7	191	130	1	1	25,51
11437841800	18	12,7	191	130	1	1	25,70
11437841850	18.5	12,7	198	135	1	1	28,05
11437841900	19	12,7	198	135	1	1	28,66
11437841950	19.5	12,7	205	140	1	1	31,55
11437842000	20	12,7	205	140	1	1	32,87
11437842100	21	12,7	205	140	1	1	43,34
11437842200	22	12,7	210	150	1	1	43,34
11437842300	23	12,7	210	150	1	1	51,18
11437842400	24	12,7	220	160	1	1	51,11
11437842500	25	12,7	220	160	1	1	56,58



BROCA A IZQUIERDAS HSS SERIE CORTA DIN 338 | TALADRADOS DE PROFUNDIDAD MEDIA <3xd | APLICACIÓN: ACEROS BLANDOS HASTA 400 N/mm²

LEFT HAND HSS DRILL SHORT SERIE DIN 338 | MEDIUM DEEP DRILLING <3xd | APPLICATION: SOFT STEELS UP TO 400 N/mm²

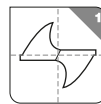
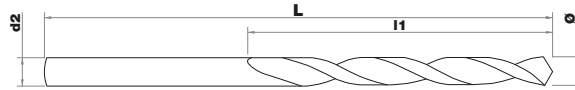

Aceros débilmente aleados <400 N/mm²
Low alloyed steels <400N/mm²

8140061	Ø	d2	L	I1	QTY	PCB	€
81400610100	1	1	34	12	1	10	6,21
81400610150	1,5	1,5	40	18	1	10	5,35
81400610180	1,8	1,8	46	22	1	10	5,22
81400610200	2	2	49	24	1	10	4,94
81400610250	2,5	2,5	57	30	1	10	5,59
81400610300	3	3	61	33	1	10	5,86
81400610310	3,1	3,1	65	36	1	10	6,21
81400610320	3,2	3,2	65	36	1	10	6,35
81400610330	3,3	3,3	65	36	1	10	6,56
81400610350	3,5	3,5	70	39	1	10	6,12
81400610400	4	4	75	43	1	10	6,66
81400610420	4,2	4,2	75	43	1	10	7,99
81400610450	4,5	4,5	80	47	1	10	8,58
81400610500	5	5	86	52	1	10	8,58
81400610520	5,2	5,2	86	52	1	10	9,89
81400610550	5,5	5,5	93	57	1	10	10,50
81400610600	6	6	93	57	1	10	10,89
81400610620	6,2	6,2	101	63	1	10	13,59
81400610650	6,5	6,5	101	63	1	10	13,08
81400610680	6,8	6,8	109	69	1	10	15,74
81400610700	7	7	109	69	1	10	14,61
81400610750	7,5	7,5	109	69	1	10	16,54
81400610800	8	8	117	75	1	10	18,98
81400610850	8,5	8,5	117	75	1	5	19,99
81400610900	9	9	125	81	1	5	25,00
81400610950	9,5	9,5	125	81	1	5	25,65
81400611000	10	10	133	87	1	5	28,82
81400611050	10,5	10,5	133	87	1	5	31,42
81400611100	11	11	142	94	1	5	37,79
81400611200	12	12	151	101	1	5	46,12
81400611300	13	13	151	101	1	5	55,69

● Hasta fin de existencias | While stocks last

**BROCA HSS FURIUS CON RECUBRIMIENTO Ti2CN | SERIE CORTA
DIN 338 | TALADRADOS DE PROFUNDIDAD MEDIA 3xd | APLICACIÓN:
ACEROS DUROS HASTA 950 N/mm²**

HSS DRILL FURIUS Ti2CN COATED | SHORT SERIE DIN 338 | MEDIUM DEEP
DRILLING 3xd | APPLICATION: HARD STEELS UP TO 950 N/mm²

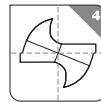
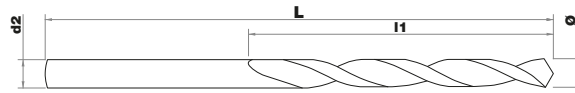

SPLIT POINT



Aceros aleados
200-700 N/mm²
Alloyed steels
200-700N/mm²



Aceros aleados
y tratados
< 950N/mm²
Heat Treatable
Steels
<950N/mm²



Fundiciones
Cast iron

1145411	Ø	d2	L	I1	QTY	PCB	€
11454110050	0,5	0,5	22	6	1	10	3,20
11454110060	0,6	0,6	24	7	1	10	3,25
11454110070	0,7	0,7	28	9	1	10	3,07
11454110080	0,8	0,8	30	10	1	10	2,84
11454110090	0,9	0,9	32	11	1	10	2,67
11454110100	1	1	34	12	1	10	2,41
11454110110	1,1	1,1	36	14	1	10	2,19
11454110120	1,2	1,2	38	16	1	10	2,58
11454110130	1,3	1,3	38	16	1	10	2,14
11454110140	1,4	1,4	40	18	1	10	2,19
11454110150	1,5	1,5	40	18	1	10	1,89
11454110160	1,6	1,6	43	20	1	10	1,94
11454110170	1,7	1,7	43	20	1	10	2,19
11454110180	1,8	1,8	46	22	1	10	1,85
11454110190	1,9	1,9	46	22	1	10	1,81
11454110200	2	2	49	24	1	10	1,56
11454110210	2,1	2,1	49	24	1	10	1,81
11454110220	2,2	2,2	53	27	1	10	1,81
11454110230	2,3	2,3	53	27	1	10	1,81
11454110240	2,4	2,4	57	30	1	10	2,01
11454110250	2,5	2,5	57	30	1	10	1,96
11454110260	2,6	2,6	57	30	1	10	1,98
11454110270	2,7	2,7	61	33	1	10	2,87
11454110280	2,8	2,8	61	33	1	10	2,45
11454110290	2,9	2,9	61	33	1	10	2,01
11454110300	3	3	61	33	1	10	2,01
11454110310	3,1	3,1	65	36	1	10	2,21
11454110320	3,2	3,2	65	36	1	10	2,18
11454110325	3,25	3,25	65	36	1	10	2,48
11454110330	3,3	3,3	65	36	1	10	2,34
11454110340	3,4	3,4	70	39	1	10	2,56
11454110350	3,5	3,5	70	39	1	10	2,22
11454110360	3,6	3,6	70	39	1	10	2,85
11454110370	3,7	3,7	70	39	1	10	2,35
11454110380	3,8	3,8	75	43	1	10	2,58
11454110390	3,9	3,9	75	43	1	10	2,77
11454110400	4	4	75	43	1	10	2,48
11454110410	4,1	4,1	75	43	1	10	2,67
11454110420	4,2	4,2	75	43	1	10	2,67
11454110425	4,25	4,25	75	43	1	10	2,93
11454110430	4,3	4,3	80	47	1	10	2,83
11454110440	4,4	4,4	80	47	1	10	3,32
11454110450	4,5	4,5	80	47	1	10	2,70
11454110460	4,6	4,6	80	47	1	10	3,54
11454110470	4,7	4,7	80	47	1	10	3,24
11454110480	4,8	4,8	86	52	1	10	2,94
11454110490	4,9	4,9	86	52	1	10	2,97
11454110500	5	5	86	52	1	10	2,88
11454110510	5,1	5,1	86	52	1	10	3,36
11454110520	5,2	5,2	86	52	1	10	3,36
11454110525	5,25	5,25	86	52	1	10	4,24
11454110530	5,3	5,3	86	52	1	10	3,36
11454110540	5,4	5,4	93	57	1	10	3,70
11454110550	5,5	5,5	93	57	1	10	3,70
11454110560	5,6	5,6	93	57	1	10	4,29
11454110570	5,7	5,7	93	57	1	10	4,00
11454110580	5,8	5,8	93	57	1	10	3,88
11454110590	5,9	5,9	93	57	1	10	4,00

**APLICACIÓN
ESPECIAL
ACEROS
DUROS**

**RECUBRIMIENTO
MULTICAPA "FUSIO"**
Color: Cobre
Composición: Ti2CN
Espesor: 2-4 µ
Dureza HV: 3200
Coef. de rozamiento: 0,2
Resist. al calor: 400 ° C

**RAPIDEZ Y
FACILIDAD DE
TALADRADO**

**MAYOR DURACIÓN DE
VIDA DE LA BROCA**

**MAYOR
PRODUCTIVIDAD**

**MAYOR PRECISIÓN Y
ESTABILIDAD.**



1145411	Ø	d2	L	I1	QTY	PCB	€
11454110600	6	6	93	57	1	10	3,88
11454110610	6,1	6,1	101	63	1	10	4,72
11454110620	6,2	6,2	101	63	1	10	4,72
11454110630	6,3	6,3	101	63	1	10	4,79
11454110640	6,4	6,4	101	63	1	10	4,89
11454110650	6,5	6,5	101	63	1	10	4,82
11454110660	6,6	6,6	101	63	1	10	4,99
11454110670	6,7	6,7	101	63	1	10	5,09
11454110675	6,75	6,75	109	69	1	10	6,02
11454110680	6,8	6,8	109	69	1	10	6,02
11454110690	6,9	6,9	109	69	1	10	6,94
11454110700	7	7	109	69	1	10	5,59
11454110710	7,1	7,1	109	69	1	10	6,02
11454110720	7,2	7,2	109	69	1	10	6,12
11454110730	7,3	7,3	109	69	1	10	6,12
11454110740	7,4	7,4	109	69	1	10	7,11
11454110750	7,5	7,5	109	69	1	10	5,81
11454110760	7,6	7,6	117	75	1	10	6,67
11454110770	7,7	7,7	117	75	1	10	7,33
11454110780	7,8	7,8	117	75	1	10	6,74
11454110790	7,9	7,9	117	75	1	10	6,82
11454110800	8	8	117	75	1	10	6,82
11454110810	8,1	8,1	117	75	1	5	7,49
11454110820	8,2	8,2	117	75	1	5	7,68
11454110830	8,3	8,3	117	75	1	5	7,62
11454110840	8,4	8,4	117	75	1	5	7,88
11454110850	8,5	8,5	117	75	1	5	7,22
11454110860	8,6	8,6	125	81	1	5	8,87
11454110870	8,7	8,7	125	81	1	5	8,87
11454110880	8,8	8,8	125	81	1	5	8,87
11454110890	8,9	8,9	125	81	1	5	9,05
11454110900	9	9	125	81	1	5	8,23
11454110910	9,1	9,1	125	81	1	5	9,05
11454110920	9,2	9,2	125	81	1	5	9,05
11454110930	9,3	9,3	125	81	1	5	9,48
11454110940	9,4	9,4	125	81	1	5	9,48
11454110950	9,5	9,5	125	81	1	5	8,81
11454110960	9,6	9,6	133	87	1	5	9,81
11454110970	9,7	9,7	133	87	1	5	9,81
11454110980	9,8	9,8	133	87	1	5	10,24
11454110990	9,9	9,9	133	87	1	5	10,24
11454111000	10	10	133	87	1	5	9,49
11454111010	10,1	10,1	133	87	1	5	12,79
11454111020	10,2	10,2	133	87	1	5	12,38
11454111025	10,25	10,25	133	87	1	5	15,62
11454111030	10,3	10,3	133	87	1	5	14,88
11454111040	10,4	10,4	133	87	1	5	14,88
11454111050	10,5	10,5	133	87	1	5	12,60
11454111100	11	11	142	94	1	5	15,70
11454111150	11,5	11,5	142	94	1	5	16,63
11454111200	12	12	151	101	1	5	17,95
11454111250	12,5	12,5	151	101	1	5	19,53
11454111300	13	13	151	101	1	5	20,18

1145416	Ø	d2	L	I1	QTY	PCB	€
11454160100	1	1	34	12	10	1	24,16
11454160150	1,5	1,5	40	18	10	1	18,85
11454160200	2	2	49	24	10	1	15,56
11454160250	2,5	2,5	57	30	10	1	19,49
11454160300	3	3	61	33	10	1	20,07
11454160320	3,2	3,2	65	36	10	1	21,72
11454160350	3,5	3,5	70	39	10	1	22,35
11454160400	4	4	75	43	10	1	24,74
11454160420	4,2	4,2	75	43	10	1	26,40
11454160450	4,5	4,5	80	47	10	1	27,00
11454160500	5	5	86	52	10	1	28,82
11454160520	5,2	5,2	86	52	10	1	33,37
11454160550	5,5	5,5	93	57	10	1	37,14
11454160600	6	6	93	57	10	1	38,63
11454160650	6,5	6,5	101	63	10	1	48,30
11454160680	6,8	6,8	109	69	10	1	60,21
11454160700	7	7	109	69	10	1	55,99
11454160750	7,5	7,5	109	69	10	1	57,96
11454160800	8	8	117	75	10	1	68,33
11454160850	8,5	8,5	117	75	5	1	36,01
11454160900	9	9	125	81	5	1	41,21





1145416	Ø	d2	L	I1	QTY	PCB	€
11454160950	9,5	9,5	125	81	5	1	44,00
11454161000	10	10	133	87	5	1	47,42
11454161100	11	11	142	94	2	1	31,43
11454161200	12	12	151	101	2	1	35,91
11454161300	13	13	151	101	2	1	40,34
1145414	Ø	d2	L	I1	QTY	PCB	€
11454140100	1	1	34	12	2	6	5,70
11454140150	1,5	1,5	40	18	2	6	4,64
11454140200	2	2	49	24	2	6	3,96
11454140250	2,5	2,5	57	30	2	6	4,75
11454140300	3	3	61	33	2	6	4,86
11454140320	3,2	3,2	65	36	2	6	5,23
11454140350	3,5	3,5	70	39	2	6	5,33
11454140400	4	4	75	43	2	6	5,83
11454140420	4,2	4,2	75	43	2	6	6,16
11454140450	4,5	4,5	80	47	2	6	6,24
11454140500	5	5	86	52	2	6	6,65
11454140550	5,5	5,5	93	57	1	6	4,58
11454140600	6	6	93	57	1	6	4,72
11454140650	6,5	6,5	101	63	1	6	5,70
11454140680	6,8	6,8	109	69	1	6	6,86
11454140700	7	7	109	69	1	6	6,47
11454140750	7,5	7,5	109	69	1	3	6,66
11454140800	8	8	117	75	1	3	7,68
11454140850	8,5	8,5	117	75	1	3	8,06
11454140900	9	9	125	81	1	3	9,09
11454140950	9,5	9,5	125	81	1	3	9,67
11454141000	10	10	133	87	1	3	10,32
11454141050	10,5	10,5	133	87	1	1	13,47
11454141100	11	11	142	94	1	1	16,55
11454141150	11,5	11,5	142	94	1	1	17,53
11454141200	12	12	151	101	1	1	18,80
11454141250	12,5	12,5	151	101	1	1	20,40
11454141300	13	13	151	101	1	1	21,03



10 BROCAS METAL HSS FURIUS

Ø 1>10 x 1mm
CLIPSTER | 10 | FURIUS

10 PCS
HSS
FUSIO COATED ø3-13mm ONLY
DIN 338
SPLIT POINT
135°

11454170004		
QTY	PCB	€
10	1	54,17



6 BROCAS METAL HSS FURIUS

Ø 2-3-4-5-6-8 mm
CLIPSTER | 6 | FURIUS

06 PCS
HSS
FUSIO COATED ø3-13mm ONLY
DIN 338
SPLIT POINT
135°

11454170005		
QTY	PCB	€
6	1	28,17



13 BROCAS METAL HSS FURIUS
 \varnothing 1,5>6,5 mm x 0,5 + 3,3 + 4,2 mm
 CLIPSTER | 13 | FURIUS

13 PCS
HSS
FUSIO COATED
 \varnothing 3-13mm ONLY
DIN 338
SPLIT POINT
135°

11454170006		
QTY	PCB	€
13	1	49,84



26 BROCAS METAL HSS FURIUS
 \varnothing 2>9 mm x 0,5 mm (\varnothing 3-4-5x2 pcs)
 \varnothing 10>13 mm x 1+3,2+4,2+6,8 mm +
 1 AVELLANADOR \varnothing 15 mm
 SET | RANGER | FURIUS

26 PCS
HSS
FUSIO COATED
 \varnothing 3-13mm ONLY
DIN 338
SPLIT POINT
135°

11454170002		
QTY	PCB	€
26	1	171,37

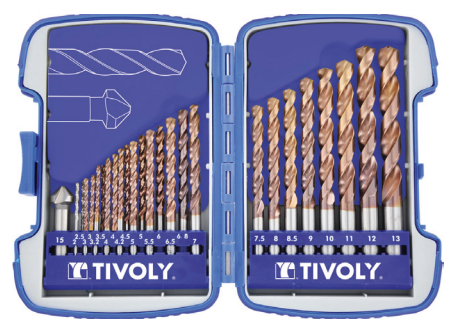

ESTUCHE DE BROCAS METAL HSS FURIUS
 \varnothing 1>10 mm x 0,5 mm
 SET | E | FURIUS

19 PCS
HSS
FUSIO COATED
 \varnothing 3-13mm ONLY
DIN 338
SPLIT POINT
135°

11454170015		
QTY	PCB	€
19	1	105,48



ESTUCHE DE BROCAS METAL HSS FURIUS
 \varnothing 1>13 mm x 0,5 mm
 SET | G | FURIUS

25 PCS
HSS
FUSIO COATED
 \varnothing 3-13mm ONLY
DIN 338
SPLIT POINT
135°

11454170017		
QTY	PCB	€
25	1	187,38



ESTUCHE DE BROCAS METAL HSS FURIUS
 $\varnothing 1 > 10,5 \text{ mm} \times 1/2 + 1,9 / 2,1 / 2,6 / 2,9 /$
 $3,2 / 3,3 / 3,8 / 4,2 / 5,1 / 6,8 / 7,9 / 10,2$
 SET | F | FURIUS

32 PCS
HSS
FUSIO COATED
 $\varnothing 3-13 \text{ mm}$
 ONLY
DIN 338
SPLIT POINT
135°

11454170009		
QTY	PCB	€
32	1	186,30



ESTUCHE DE BROCAS METAL HSS FURIUS
 $\varnothing 1 > 8 \text{ mm} \times 1 \text{ mm}$
 SET | C | FURIUS

51 PCS
HSS
FUSIO COATED
 $\varnothing 3-13 \text{ mm}$
 ONLY
DIN 338
SPLIT POINT
135°

11454170010		
QTY	PCB	€
51	1	196,07



ESTUCHE DE BROCAS METAL HSS FURIUS
 $\varnothing 6 > 10 \text{ mm} \times 1 \text{ mm}$
 SET | D | FURIUS

41 PCS
HSS
FUSIO COATED
 $\varnothing 3-13 \text{ mm}$
 ONLY
DIN 338
SPLIT POINT
135°

11454170011		
QTY	PCB	€
41	1	426,42



ESTUCHE DE BROCAS METAL HSS FURIUS
 $\varnothing 1 > 10 \text{ mm} \times 1 + \varnothing 10 \text{ mm}$
 SET | J | FURIUS

91 PCS
HSS
FUSIO COATED
 $\varnothing 3-13 \text{ mm}$
 ONLY
DIN 338
SPLIT POINT
135°

11454170008		
QTY	PCB	€
91	1	570,72



**BROCA ACERO COBALTO 5% (HSSE5) SERIE CORTA DIN 338 |
TALADRADOS DE PROFUNDIDAD MEDIA < 3xd | APLICACIÓN: ACEROS
SEMI-DUROS HASTA 700 N/mm², INOXIDABLES**

COBALT DRILL 5% (HSSE5) SHORT SERIE DIN 338 | MEDIUM DEEP DRILLING <3xd |
APPLICATION: SEMI-HARD STEELS UP TO 700 N/mm² AND STAINLESS STEELS

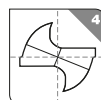
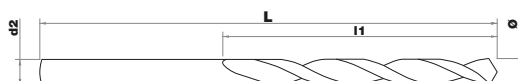

SPLIT POINT



Aceros aleados
200-700 N/mm²
Alloyed steels
200-700N/mm²



Aceros
inoxidables
ferríticos
Ferritic
stainless
steels

1145501	Ø	d2	L	l1	QTY	PCB	€
11455010100	1	1	34	12	1	1	1,35
11455010110	1,1	1,1	36	14	1	10	1,27
11455010120	1,2	1,2	38	16	1	10	1,32
11455010125	1,25	1,25	38	16	1	10	1,45
11455010130	1,3	1,3	38	16	1	10	1,27
11455010140	1,4	1,4	40	18	1	10	1,27
11455010150	1,5	1,5	40	18	1	10	1,16
11455010160	1,6	1,6	43	20	1	10	1,44
11455010170	1,7	1,7	43	20	1	10	1,44
11455010175	1,75	1,75	46	22	1	10	1,51
11455010180	1,8	1,8	46	22	1	10	1,45
11455010190	1,9	1,9	46	22	1	10	1,45
11455010200	2	2	49	24	1	10	1,27
11455010210	2,1	2,1	49	24	1	10	1,60
11455010220	2,2	2,2	53	27	1	10	1,60
11455010225	2,25	2,25	53	27	1	10	1,55
11455010230	2,3	2,3	53	27	1	10	1,64
11455010240	2,4	2,4	57	30	1	10	1,64
11455010250	2,5	2,5	57	30	1	10	1,43
11455010260	2,6	2,6	57	30	1	10	1,55
11455010270	2,7	2,7	61	33	1	10	1,55
11455010275	2,75	2,75	61	33	1	10	1,55
11455010280	2,8	2,8	61	33	1	10	1,58
11455010290	2,9	2,9	61	33	1	10	1,58
11455010300	3	3	61	33	1	10	1,29
11455010310	3,1	3,1	65	36	1	10	1,66
11455010320	3,2	3,2	65	36	1	10	1,60
11455010325	3,25	3,25	65	36	1	10	1,60
11455010330	3,3	3,3	65	36	1	10	1,65
11455010340	3,4	3,4	70	39	1	10	1,69
11455010350	3,5	3,5	70	39	1	10	1,60
11455010360	3,6	3,6	70	39	1	10	1,80
11455010370	3,7	3,7	70	39	1	10	1,80
11455010375	3,75	3,75	70	39	1	10	1,82
11455010380	3,8	3,8	75	43	1	10	1,79
11455010390	3,9	3,9	75	43	1	10	1,79
11455010400	4	4	75	43	1	10	1,65
11455010410	4,1	4,1	75	43	1	10	2,25
11455010420	4,2	4,2	75	43	1	10	1,97
11455010425	4,25	4,25	75	43	1	10	1,84
11455010430	4,3	4,3	80	47	1	10	2,11
11455010440	4,4	4,4	80	47	1	10	2,11
11455010450	4,5	4,5	80	47	1	10	1,84
11455010460	4,6	4,6	80	47	1	10	2,35
11455010470	4,7	4,7	80	47	1	10	2,35
11455010475	4,75	4,75	80	47	1	10	2,19
11455010480	4,8	4,8	86	52	1	10	2,36
11455010490	4,9	4,9	86	52	1	10	2,36
11455010500	5	5	86	52	1	10	2,06
11455010510	5,1	5,1	86	52	1	10	2,33
11455010520	5,2	5,2	86	52	1	10	2,54
11455010525	5,25	5,25	86	52	1	10	2,38
11455010530	5,3	5,3	86	52	1	10	2,64
11455010540	5,4	5,4	93	57	1	10	2,64



1145501	Ø	d2	L	I1	QTY	PCB	€
11455010550	5,5	5,5	93	57	1	10	2,58
11455010560	5,6	5,6	93	57	1	10	3,21
11455010570	5,7	5,7	93	57	1	10	3,21
11455010575	5,75	5,75	93	57	1	10	2,80
11455010580	5,8	5,8	93	57	1	10	3,11
11455010590	5,9	5,9	93	57	1	10	3,11
11455010600	6	6	93	57	1	10	2,79
11455010610	6,1	6,1	101	63	1	10	3,90
11455010620	6,2	6,2	101	63	1	10	3,90
11455010625	6,25	6,25	101	63	1	10	3,31
11455010630	6,3	6,3	101	63	1	10	3,83
11455010640	6,4	6,4	101	63	1	10	3,83
11455010650	6,5	6,5	101	63	1	10	3,43
11455010660	6,6	6,6	101	63	1	10	4,09
11455010670	6,7	6,7	101	63	1	10	4,09
11455010675	6,75	6,75	109	69	1	10	3,83
11455010680	6,8	6,8	109	69	1	10	4,37
11455010690	6,9	6,9	109	69	1	10	4,37
11455010700	7	7	109	69	1	10	3,63
11455010710	7,1	7,1	109	69	1	10	5,17
11455010720	7,2	7,2	109	69	1	10	5,17
11455010725	7,25	7,25	109	69	1	10	4,23
11455010730	7,3	7,3	109	69	1	10	4,78
11455010740	7,4	7,4	109	69	1	10	4,78
11455010750	7,5	7,5	109	69	1	10	4,09
11455010760	7,6	7,6	117	75	1	10	5,84
11455010770	7,7	7,7	117	75	1	10	5,67
11455010775	7,75	7,75	117	75	1	10	4,88
11455010780	7,8	7,8	117	75	1	10	5,52
11455010790	7,9	7,9	117	75	1	10	5,52
11455010800	8	8	117	75	1	10	4,63
11455010810	8,1	8,1	117	75	1	5	6,38
11455010820	8,2	8,2	117	75	1	5	6,38
11455010825	8,25	8,25	117	75	1	5	5,25
11455010830	8,3	8,3	117	75	1	5	6,48
11455010840	8,4	8,4	117	75	1	5	6,48
11455010850	8,5	8,5	117	75	1	5	4,91
11455010860	8,6	8,6	125	81	1	5	6,93
11455010870	8,7	8,7	125	81	1	5	6,93
11455010875	8,75	8,75	125	81	1	5	5,93
11455010880	8,8	8,8	125	81	1	5	6,89
11455010890	8,9	8,9	125	81	1	5	6,89
11455010900	9	9	125	81	1	5	5,98
11455010910	9,1	9,1	125	81	1	5	8,12
11455010920	9,2	9,2	125	81	1	5	8,12
11455010925	9,25	9,25	125	81	1	5	6,73
11455010930	9,3	9,3	125	81	1	5	7,83
11455010940	9,4	9,4	125	81	1	5	7,83
11455010950	9,5	9,5	125	81	1	5	6,26
11455010960	9,6	9,6	133	87	1	5	9,40
11455010970	9,7	9,7	133	87	1	5	9,40
11455010980	9,8	9,8	133	87	1	5	9,54
11455010990	9,9	9,9	133	87	1	5	9,55
11455011000	10	10	133	87	1	5	6,78
11455011010	10,1	10,1	133	87	1	5	10,37
11455011020	10,2	10,2	133	87	1	5	10,37
11455011025	10,25	10,25	133	87	1	5	15,60
11455011030	10,3	10,3	133	87	1	5	10,80
11455011040	10,4	10,4	133	87	1	5	10,80
11455011050	10,5	10,5	133	87	1	5	8,94
11455011100	11	11	142	94	1	5	10,33
11455011150	11,5	11,5	142	94	1	5	11,97
11455011200	12	12	151	101	1	5	12,28
11455011250	12,5	12,5	151	101	1	5	13,91
11455011300	13	13	151	101	1	5	15,58
11455011350	13,5	13,5	160	108	1	5	17,47
11455011400	14	14	160	108	1	5	18,55
11455011500	15	15	168	114	1	5	25,96
11455011600	16	16	178	120	1	5	31,33



1145504	Ø	L	I	QTY	PCB	€
11455040100	1	34		2	6	2,53
11455040150	1,5	40		2	6	2,15
11455040200	2	49		2	6	2,37
11455040225	2,25	53		2	6	2,89
11455040250	2,5	57		2	6	2,64
11455040300	3	61		2	6	2,40
11455040325	3,25	65		2	6	3,01
11455040350	3,5	70		2	6	3,01



1145504	Ø	L	I	QTY	PCB	€
11455040400	4	75		2	6	3,12
11455040425	4,25	75		2	6	3,47
11455040450	4,5	80		2	6	3,47
11455040500	5	86		2	6	3,83
11455040520	5,2	86		1	6	2,42
11455040550	5,5	93		1	6	2,42
11455040600	6	93		1	6	2,58
11455040650	6,5	101		1	6	3,19
11455040680	6,8	109		1	6	3,40
11455040700	7	109		1	6	3,40
11455040750	7,5	109		1	3	3,83
11455040800	8	117		1	3	4,33
11455040850	8,5	117		1	3	4,61
11455040900	9	125		1	3	5,57
11455040950	9,5	125		1	3	5,88
11455041000	10	133		1	3	6,34
11455041050	10,5	133		1	1	8,34
11455041100	11	142		1	1	9,66
11455041150	11,5	142		1	1	11,18
11455041200	12	151		1	1	11,45
11455041250	12,5	151		1	1	13,01
11455041300	13	151		1	1	14,56

**ESTUCHE DE BROCAS ACERO COBALTO 5%
DIN 338 | Ø 1-10 x 0,5 mm**

COBALT DRILL 5% SET DIN 338 |
Ø1-10 x 0,5 mm



11455070015		
QTY	PCB	€
19	1	61,73



**ESTUCHE DE BROCAS ACERO COBALTO
5% DIN 338 | Ø 1-13 x 0,5 mm**

COBALT DRILL 5% SET DIN 338 |
Ø1-13 x 0,5 mm



11455070017		
QTY	PCB	€
25	1	136,78





BROCA ACERO COBALTO 5% (HSSE5) SERIE CORTA DIN 338 | MANGO REDUCIDO | TALADRADOS DE PROFUNDIDAD MEDIA <3xd | APLICACIÓN: ACEROS SEMI-DUROS HASTA 700 N/mm², INOXIDABLES

COBALT DRILL 5% (HSSE5) SHORT SERIE DIN 338 | REDUCED SHANK | MEDIUM DEEP DRILLING <3xd | SEMI-HARD STEELS UP TO 700 N/mm², STAINLESS STEELS

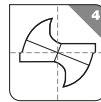
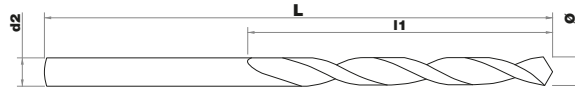

SPLIT POINT

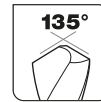

Aceros aleados
200-700 N/mm²
Alloyed steels
200-700N/mm²



Aceros
inoxidables
ferríticos
Ferritic
stainless
steels

1145561	Ø	d2	L	I1	QTY	PCB	€
11455611400	14	12,7	160	108	1	1	35,05
11455611450	14,5	12,7	169	114	1	1	38,03
11455611500	15	12,7	169	114	1	1	38,91
11455611550	15,5	12,7	178	120	1	1	42,21
11455611600	16	12,7	178	120	1	1	42,80
11455611650	16,5	12,7	184	125	1	1	46,43
11455611700	17	12,7	184	125	1	1	51,06
11455611750	17,5	12,7	191	130	1	1	54,34
11455611800	18	12,7	191	130	1	1	55,97
11455611850	18,5	12,7	198	135	1	1	57,40
11455611900	19	12,7	198	135	1	1	60,82
11455611950	19,5	12,7	205	140	1	1	64,47
11455612000	20	12,7	205	140	1	1	64,84



BROCA CUTINOX ACERO COBALTO 5% (HSSE5) SERIE CORTA DIN 338 | TALADRADOS DE PROFUNDIDAD MEDIA <3xd | APLICACIÓN: ACEROS INOXIDABLES FERRÍTICOS

CUTINOX COBALT DRILL 5% (HSSE5) SHORT SERIE DIN 338 | MEDIUM DEEP DRILLING <3xd | APPLICATIONS: FERRITICS STAINLESS STEELS

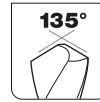
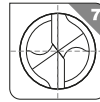
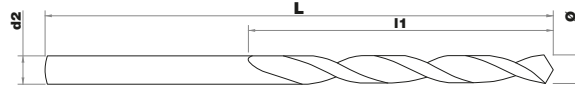

Aceros
inoxidables
ferríticos
Ferritic
stainless
steels

1145581	Ø	d2	L	I1	QTY	PCB	€
11455810080	0,8	0,8	30	10	1	10	4,58
11455810090	0,9	0,9	32	11	1	10	4,53
11455810100	1	1	34	12	1	10	4,15
11455810110	1,1	1,1	36	14	1	10	4,17
11455810120	1,2	1,2	38	16	1	10	4,61
11455810130	1,3	1,3	36	16	1	10	4,41
11455810140	1,4	1,4	40	18	1	10	4,12
11455810150	1,5	1,5	40	18	1	10	3,83
11455810160	1,6	1,6	43	20	1	10	4,53
11455810170	1,7	1,7	43	20	1	10	4,26
11455810180	1,8	1,8	46	22	1	10	4,26
11455810190	1,9	1,9	46	22	1	10	4,31
11455810200	2	2	49	24	1	10	3,52
11455810210	2,1	2,1	49	24	1	10	4,41
11455810220	2,2	2,2	53	27	1	10	4,41
11455810230	2,3	2,3	53	27	1	10	4,41
11455810240	2,4	2,4	57	30	1	10	4,45
11455810250	2,5	2,5	57	30	1	10	2,67
11455810260	2,6	2,6	57	30	1	10	2,72
11455810270	2,7	2,7	61	33	1	10	2,72
11455810275	2,75	2,75	61	33	1	10	5,46
11455810280	2,8	2,8	61	33	1	10	2,76
11455810290	2,9	2,9	61	33	1	10	3,64
11455810300	3	3	61	33	1	10	2,39
11455810310	3,1	3,1	65	36	1	10	2,93
11455810320	3,2	3,2	65	36	1	10	2,70
11455810325	3,25	3,25	65	36	1	10	3,10
11455810330	3,3	3,3	65	36	1	10	3,10
11455810340	3,4	3,4	70	39	1	10	3,10
11455810350	3,5	3,5	70	39	1	10	2,84
11455810360	3,6	3,6	70	39	1	10	3,86
11455810370	3,7	3,7	70	39	1	10	3,89
11455810375	3,75	3,75	70	39	1	10	5,92
11455810380	3,8	3,8	75	43	1	10	3,92
11455810390	3,9	3,9	75	43	1	10	4,09
11455810400	4	4	75	43	1	10	3,11
11455810410	4,1	4,1	75	43	1	10	3,50
11455810420	4,2	4,2	75	43	1	10	3,50
11455810425	4,25	4,25	75	43	1	10	3,83
11455810430	4,3	4,3	80	47	1	10	3,84
11455810440	4,4	4,4	80	47	1	10	4,59
11455810450	4,5	4,5	80	47	1	10	3,57
11455810460	4,6	4,6	80	47	1	10	4,66

AFILADO 4 CARAS "PLANO"

Un concentrado de tecnología:

- ▶ Incidencia principal + secundaria planas
- ▶ Ángulo de incidencia constante
- ▶ Asociado a una geometría optimizada de aguzado del núcleo y perfil de estrias, este afilado aporta a las nuevas brocas de cobalto TBX 4F:
- ▶ Estabilidad geométrica fillos de corte reforzados
- ▶ Distribución uniforme del desgaste
- ▶ Fragmentación de la viruta
- ▶ Autocentrado



COBALTO INOX 4F



1145581	Ø	d2	L	I1	QTY	PCB	€
11455810470	4,7	4,7	80	47	1	10	4,07
11455810475	4,75	4,75	80	47	1	10	6,08
11455810480	4,8	4,8	86	52	1	10	4,07
11455810490	4,9	4,9	86	52	1	10	4,12
11455810500	5	5	86	52	1	10	3,80
11455810510	5,1	5,1	86	52	1	10	4,36
11455810520	5,2	5,2	86	52	1	10	4,36
11455810525	5,25	5,25	86	52	1	10	4,82
11455810530	5,3	5,3	86	52	1	10	4,81
11455810540	5,4	5,4	93	57	1	10	6,35
11455810550	5,5	5,5	93	57	1	10	5,06
11455810560	5,6	5,6	93	57	1	10	5,73
11455810570	5,7	5,7	93	57	1	10	5,97
11455810575	5,75	5,75	93	57	1	10	8,07
11455810580	5,8	5,8	93	57	1	10	5,39
11455810590	5,9	5,9	93	57	1	10	6,09
11455810600	6	6	93	57	1	10	5,22
11455810610	6,1	6,1	101	63	1	10	5,81
11455810620	6,2	6,2	101	63	1	10	5,81
11455810625	6,25	6,25	101	63	1	10	5,91
11455810630	6,3	6,3	101	63	1	10	5,92
11455810640	6,4	6,4	101	63	1	10	6,72
11455810650	6,5	6,5	101	63	1	10	5,99
11455810660	6,6	6,6	101	63	1	10	7,80
11455810670	6,7	6,7	101	63	1	10	6,38
11455810675	6,75	6,75	109	69	1	10	8,01
11455810680	6,8	6,8	109	69	1	10	8,01
11455810690	6,9	6,9	109	69	1	10	7,83
11455810700	7	7	109	69	1	10	7,23
11455810710	7,1	7,1	109	69	1	10	7,94
11455810720	7,2	7,2	109	69	1	10	8,16
11455810730	7,3	7,3	109	69	1	10	8,16
11455810740	7,4	7,4	109	69	1	10	8,24
11455810750	7,5	7,5	109	69	1	10	7,56
11455810760	7,6	7,6	117	75	1	10	8,96
11455810770	7,7	7,7	117	75	1	10	9,70
11455810780	7,8	7,8	117	75	1	10	9,08
11455810790	7,9	7,9	117	75	1	10	9,30
11455810800	8	8	117	75	1	10	8,62
11455810810	8,1	8,1	117	75	1	5	9,48
11455810820	8,2	8,2	117	75	1	5	9,76
11455810830	8,3	8,3	117	75	1	5	9,68
11455810840	8,4	8,4	117	75	1	5	10,04
11455810850	8,5	8,5	117	75	1	5	9,11
11455810860	8,6	8,6	125	81	1	5	11,67
11455810870	8,7	8,7	125	81	1	5	11,67
11455810880	8,8	8,8	125	81	1	5	11,67
11455810890	8,9	8,9	125	81	1	5	11,95
11455810900	9	9	125	81	1	5	9,30
11455810910	9,1	9,1	125	81	1	5	11,95
11455810920	9,2	9,2	125	81	1	5	11,95
11455810930	9,3	9,3	125	81	1	5	12,61
11455810940	9,4	9,4	125	81	1	5	12,61
11455810950	9,5	9,5	125	81	1	5	12,35
11455810960	9,6	9,6	133	87	1	5	13,21
11455810970	9,7	9,7	133	87	1	5	13,21
11455810980	9,8	9,8	133	87	1	5	13,87
11455810990	9,9	9,9	133	87	1	5	13,87
11455811000	10	10	133	87	1	5	13,27
11455811020	10,2	10,2	133	87	1	5	16,07
11455811050	10,5	10,5	133	87	1	5	14,29
11455811100	11	11	142	94	1	5	15,78
11455811150	11,5	11,5	142	94	1	5	16,93
11455811200	12	12	151	101	1	5	18,22
11455811250	12,5	12,5	151	101	1	5	19,62
11455811300	13	13	151	101	1	5	20,19

ESTUCHE | E | CUTINOX 4F
Ø1-10 mm x 0,5 mm
 SET | E | CUTINOX 4F



19 PCS	HSS E5	BRIGHT UNCOATED	DIN 338		135°
------------------	-------------------------	---------------------------	--------------------------	--	-------------

11455870015		
QTY	PCB	€
19	1	121,92

ESTUCHE | G | CUTINOX 4F
Ø1-13 mm x 0,5 mm
 SET | G | CUTINOX 4F



25 PCS	HSS E5	BRIGHT UNCOATED	DIN 338		135°
------------------	-------------------------	---------------------------	--------------------------	--	-------------

11455870017		
QTY	PCB	€
25	1	264,62

BROCA TBX ACERO COBALTO 5% (HSSE5) CON RECUBRIMIENTO BLADE | SERIE CORTA DIN 338 | TALADRADOS DE PROFUNDIDAD MEDIA <3xd | APLICACIÓN: ACEROS INOXIDABLES Y ACEROS DUROS HASTA 1200 N/mm²

TBX COBALT DRILL 5% (HSSE5) BLADE | SHORT SERIE DIN 338 | MEDIUM DEEP DRILLING <3xd | APPLICATION: STAINLESS STEELS AND HARD STEELS UP TO 1200 N/mm²

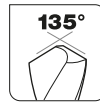
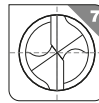
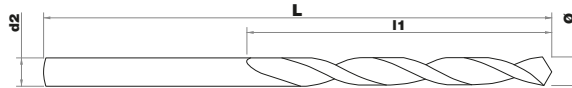

Aceros inoxidables ferríticos
Ferritic stainless steels



Aceros inoxidables martensíticos
Martensitic stainless steels



Aceros inoxidables austeníticos
Austenitic stainless steels



Aceros aleados y tratados <1200 N/mm²
Heat treatable steels <1200 N/mm²

1145611	Ø	d2	L	l1	QTY	PCB	€
11456110100	1	1	34	12	1	10	2,52
11456110110	1,1	1,1	36	14	1	10	3,72
11456110120	1,2	1,2	38	16	1	10	4,35
11456110130	1,3	1,3	38	16	1	10	3,60
11456110140	1,4	1,4	40	18	1	10	3,72
11456110150	1,5	1,5	40	18	1	10	2,61
11456110160	1,6	1,6	43	20	1	10	3,27
11456110170	1,7	1,7	43	20	1	10	3,72
11456110180	1,8	1,8	46	22	1	10	3,08
11456110190	1,9	1,9	46	22	1	10	3,04
11456110200	2	2	49	24	1	10	2,63
11456110210	2,1	2,1	49	24	1	10	3,04
11456110220	2,2	2,2	53	27	1	10	3,04
11456110230	2,3	2,3	53	27	1	10	3,04
11456110240	2,4	2,4	57	30	1	10	3,41
11456110250	2,5	2,5	57	30	1	10	3,33
11456110260	2,6	2,6	57	30	1	10	3,40
11456110270	2,7	2,7	61	33	1	10	3,40
11456110280	2,8	2,8	61	33	1	10	3,44
11456110290	2,9	2,9	61	33	1	10	4,53
11456110300	3	3	61	33	1	10	2,93
11456110310	3,1	3,1	65	36	1	10	3,64
11456110320	3,2	3,2	65	36	1	10	3,37
11456110330	3,3	3,3	65	36	1	10	3,83
11456110340	3,4	3,4	70	39	1	10	3,83
11456110350	3,5	3,5	70	39	1	10	3,53
11456110360	3,6	3,6	70	39	1	10	4,80
11456110370	3,7	3,7	70	39	1	10	4,85
11456110380	3,8	3,8	75	43	1	10	4,89
11456110390	3,9	3,9	75	43	1	10	5,06
11456110400	4	4	75	43	1	10	3,85
11456110410	4,1	4,1	75	43	1	10	4,33
11456110420	4,2	4,2	75	43	1	10	4,33
11456110430	4,3	4,3	80	47	1	10	4,76
11456110440	4,4	4,4	80	47	1	10	5,70
11456110450	4,5	4,5	80	47	1	10	4,45
11456110460	4,6	4,6	80	47	1	10	5,79
11456110470	4,7	4,7	80	47	1	10	5,03
11456110480	4,8	4,8	86	52	1	10	5,03
11456110490	4,9	4,9	86	52	1	10	5,12
11456110500	5	5	86	52	1	10	4,70
11456110510	5,1	5,1	86	52	1	10	5,40
11456110520	5,2	5,2	86	52	1	10	5,40
11456110530	5,3	5,3	86	52	1	10	5,97
11456110540	5,4	5,4	93	57	1	10	7,88
11456110550	5,5	5,5	93	57	1	10	6,28
11456110560	5,6	5,6	93	57	1	10	7,11
11456110570	5,7	5,7	93	57	1	10	7,40
11456110580	5,8	5,8	93	57	1	10	6,69
11456110590	5,9	5,9	93	57	1	10	7,56
11456110600	6	6	93	57	1	10	6,48
11456110610	6,1	6,1	101	63	1	10	7,22

AFILADO 4 CARAS "PLANO"

- Un concentrado de tecnología:
- ▶ Incidencia principal + secundaria planas
 - ▶ Ángulo de incidencia constante
 - ▶ Asociado a una geometría optimizada de aguzado del núcleo y perfil de estrías, este afilado aporta a las nuevas brocas de cobalto TBX 4F:
 - ▶ Estabilidad geométrica fillos de corte reforzados
 - ▶ Distribución uniforme del desgaste
 - ▶ Fragmentación de la viruta
 - ▶ Autocentrado



COBALTO INOX 4F



1145611	Ø	d2	L	I1	QTY	PCB	€
11456110620	6,2	6,2	101	63	1	10	7,22
11456110630	6,3	6,3	101	63	1	10	7,33
11456110640	6,4	6,4	101	63	1	10	8,31
11456110650	6,5	6,5	101	63	1	10	7,43
11456110660	6,6	6,6	101	63	1	10	9,67
11456110670	6,7	6,7	101	63	1	10	7,93
11456110680	6,8	6,8	109	69	1	10	9,94
11456110690	6,9	6,9	109	69	1	10	9,70
11456110700	7	7	109	69	1	10	8,95
11456110710	7,1	7,1	109	69	1	10	9,84
11456110720	7,2	7,2	109	69	1	10	10,14
11456110730	7,3	7,3	109	69	1	10	10,14
11456110740	7,4	7,4	109	69	1	10	10,23
11456110750	7,5	7,5	109	69	1	10	9,40
11456110760	7,6	7,6	117	75	1	10	11,11
11456110770	7,7	7,7	117	75	1	10	12,01
11456110780	7,8	7,8	117	75	1	10	11,25
11456110790	7,9	7,9	117	75	1	10	11,54
11456110800	8	8	117	75	1	10	10,71
11456110810	8,1	8,1	117	75	1	5	11,76
11456110820	8,2	8,2	117	75	1	5	12,11
11456110830	8,3	8,3	117	75	1	5	11,98
11456110840	8,4	8,4	117	75	1	5	12,47
11456110850	8,5	8,5	117	75	1	5	11,29
11456110860	8,6	8,6	125	81	1	5	14,47
11456110870	8,7	8,7	125	81	1	5	14,47
11456110880	8,8	8,8	125	81	1	5	14,47
11456110890	8,9	8,9	125	81	1	5	14,81
11456110900	9	9	125	81	1	5	11,54
11456110910	9,1	9,1	125	81	1	5	14,81
11456110920	9,2	9,2	125	81	1	5	14,81
11456110930	9,3	9,3	125	81	1	5	15,65
11456110940	9,4	9,4	125	81	1	5	15,65
11456110950	9,5	9,5	125	81	1	5	15,33
11456110960	9,6	9,6	133	87	1	5	16,40
11456110970	9,7	9,7	133	87	1	5	16,40
11456110980	9,8	9,8	133	87	1	5	17,19
11456110990	9,9	9,9	133	87	1	5	17,19
11456111000	10	10	133	87	1	5	16,47
11456111020	10,2	10,2	133	87	1	5	19,95
11456111050	10,5	10,5	133	87	1	5	17,75
11456111100	11	11	142	94	1	5	19,56
11456111150	11,5	11,5	142	94	1	5	21,00
11456111200	12	12	151	101	1	5	22,61
11456111250	12,5	12,5	151	101	1	5	24,35
11456111300	13	13	151	101	1	5	25,03
11456111400	14	12	160	108	1	1	47,76
11456111500	15	12	169	114	1	1	51,57
11456111600	16	12	178	120	1	1	61,82
11456111700	17	12	184	125	1	1	69,33
11456111800	18	12	191	130	1	1	83,37
11456111900	19	12	198	135	1	1	91,95
11456112000	20	12	205	140	1	1	115,69

1145614	Ø	d2	L	I1	QTY	PCB	€
11456140300	3	3	61	33	1	3	3,78
11456140320	3,2	3,2	65	36	1	3	4,22
11456140350	3,5	3,5	70	39	1	3	4,36
11456140400	4	4	75	43	1	3	4,70
11456140420	4,2	4,2	75	43	1	3	5,21
11456140450	4,5	4,5	80	47	1	3	5,29
11456140500	5	5	86	52	1	3	5,57
11456140520	5,2	5,2	86	52	1	3	6,26
11456140550	5,5	5,5	93	57	1	3	7,15
11456140600	6	6	93	57	1	3	7,35
11456140650	6,5	6,5	101	63	1	3	8,27
11456140700	7	7	109	69	1	1	9,81
11456140750	7,5	7,5	109	69	1	1	10,23
11456140800	8	8	117	75	1	1	11,58
11456140850	8,5	8,5	117	75	1	1	12,16
11456140900	9	9	125	81	1	1	12,38
11456140950	9,5	9,5	125	81	1	1	16,16
11456141000	10	10	133	87	1	1	17,33
11456141050	10,5	10,5	133	87	1	1	18,59
11456141100	11	11	142	94	1	1	20,40
11456141150	11,5	11,5	142	94	1	1	21,84
11456141200	12	12	151	101	1	1	23,47
11456141250	12,5	12,5	151	101	1	1	25,19
11456141300	13	13	151	101	1	1	25,89





1145616	Ø	d2	L	I1	QTY	PCB	€
11456160300	3	3	61	33	10	1	29,37
11456160320	3,2	3,2	65	36	10	1	33,56
11456160350	3,5	3,5	70	39	10	1	35,18
11456160400	4	4	75	43	10	1	38,41
11456160420	4,2	4,2	75	43	10	1	43,42
11456160450	4,5	4,5	80	47	10	1	44,45
11456160500	5	5	86	52	10	1	47,11
11456160550	5,5	5,5	93	57	10	1	62,79
11456160600	6	6	93	57	10	1	64,77
11456160650	6,5	6,5	101	63	10	1	74,17
11456160700	7	7	109	69	10	1	89,68
11456160800	8	8	117	75	10	1	107,03

ESTUCHE | E | TBX 4F
Ø 1>10 mm x 0,5 mm
 SET | E | TBX 4F



**19
PCS**

**HSS
E5**

**BLADE
COATED**
Ø3-13mm
ONLY

**DIN
338**

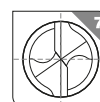

11456170015		
QTY	PCB	€
19	1	151,26

ESTUCHE | G | TBX 4F
Ø 1>13 mm x 0,5 mm
 SET | G | TBX 4F



**25
PCS**

**HSS
E5**

**BLADE
COATED**
Ø3-13mm
ONLY

**DIN
338**

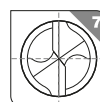

11456170017		
QTY	PCB	€
25	1	328,32



**BROCA ACERO COBALTO 8% (HSSE8) SERIE CORTA DIN 338 |
TALADRADOS DE PROFUNDIDAD MEDIA <3xd | APLICACIÓN:
ALEACIONES REFRACTARIAS Co/Ni Y ALEACIONES DE TITANIO**

COBALT DRILL 8% (HSSE8) | SHORT SERIE DIN 338 | MEDIUM DEEP DRILLING
<3xd | APPLICATION: Co/Ni BASED SPECIAL ALLOYS AND TITANIUM ALLOYS

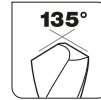
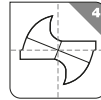
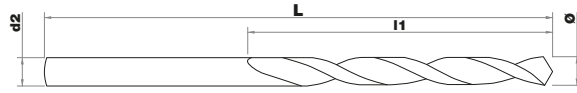

Aleaciones refractarias Co / Ni
Ni / Co based special alloys



Aleaciones de titanio
Titanium alloys

8140161	Ø	d2	L	I1	QTY	PCB	€
81401610200	2	2	49	24	1	10	4,76
81401610210	2,1	2,1	49	24	1	10	5,99
81401610220	2,2	2,2	53	27	1	10	5,33
81401610225	2,25	2,25	53	27	1	10	10,16
81401610230	2,3	2,3	53	27	1	10	8,96
81401610240	2,4	2,4	57	30	1	10	5,28
81401610250	2,5	2,5	57	30	1	10	5,09
81401610260	2,6	2,6	57	30	1	10	6,09
81401610270	2,7	2,7	61	33	1	10	6,01
81401610275	2,75	2,75	61	33	1	10	10,14
81401610280	2,8	2,8	61	33	1	10	6,02
81401610290	2,9	2,9	61	33	1	10	5,61
81401610300	3	3	61	33	1	10	4,59
81401610310	3,1	3,1	65	36	1	10	6,41
81401610320	3,2	3,2	65	36	1	10	5,61
81401610325	3,25	3,25	65	36	1	10	5,69
81401610330	3,3	3,3	65	36	1	10	5,88
81401610340	3,4	3,4	70	39	1	10	6,06
81401610350	3,5	3,5	70	39	1	10	5,61
81401610360	3,6	3,6	70	39	1	10	7,19
81401610370	3,7	3,7	70	39	1	10	7,82
81401610375	3,75	3,75	70	39	1	10	9,88
81401610380	3,8	3,8	75	43	1	10	6,26
81401610390	3,9	3,9	75	43	1	10	6,46
81401610400	4	4	75	43	1	10	6,06
81401610410	4,1	4,1	75	43	1	10	6,56
81401610420	4,2	4,2	75	43	1	10	6,63
81401610425	4,25	4,25	75	43	1	10	6,52
81401610430	4,3	4,3	80	47	1	10	7,03
81401610440	4,4	4,4	80	47	1	10	9,33
81401610450	4,5	4,5	80	47	1	10	6,74
81401610460	4,6	4,6	80	47	1	10	8,33
81401610470	4,7	4,7	80	47	1	10	7,56
81401610475	4,75	4,75	80	47	1	10	7,46
81401610480	4,8	4,8	86	52	1	10	7,66
81401610490	4,9	4,9	86	52	1	10	7,80
81401610500	5	5	86	52	1	10	7,21
81401610510	5,1	5,1	86	52	1	10	7,88
81401610520	5,2	5,2	86	52	1	10	7,98
81401610525	5,25	5,25	86	52	1	10	8,10
81401610530	5,3	5,3	86	52	1	10	8,10
81401610540	5,4	5,4	93	57	1	10	15,12
81401610550	5,5	5,5	93	57	1	10	9,25
81401610560	5,6	5,6	93	57	1	10	10,21
81401610570	5,7	5,7	93	57	1	10	10,21
81401610575	5,75	5,75	93	57	1	10	10,21
81401610580	5,8	5,8	93	57	1	10	10,21
81401610590	5,9	5,9	93	57	1	10	10,21
81401610600	6	6	93	57	1	10	9,67
81401610610	6,1	6,1	101	63	1	10	11,29
81401610620	6,2	6,2	101	63	1	10	11,41
81401610625	6,25	6,25	101	63	1	10	11,41
81401610630	6,3	6,3	101	63	1	10	11,41
81401610640	6,4	6,4	101	63	1	10	13,56
81401610650	6,5	6,5	101	63	1	10	11,29
81401610660	6,6	6,6	101	63	1	10	12,33



8140161	Ø	d2	L	I1	QTY	PCB	€
81401610670	6,7	6,7	101	63	1	10	12,33
81401610675	6,75	6,75	109	69	1	10	13,23
81401610680	6,8	6,8	109	69	1	10	13,23
81401610690	6,9	6,9	109	69	1	10	13,23
81401610700	7	7	109	69	1	10	11,91
81401610710	7,1	7,1	109	69	1	10	16,11
81401610720	7,2	7,2	109	69	1	10	16,11
81401610725	7,25	7,25	109	69	1	10	16,11
81401610730	7,3	7,3	109	69	1	10	16,11
81401610740	7,4	7,4	109	69	1	10	16,11
81401610750	7,5	7,5	109	69	1	10	12,65
81401610760	7,6	7,6	117	75	1	10	19,54
81401610770	7,7	7,7	117	75	1	10	19,54
81401610775	7,75	7,75	117	75	1	10	19,54
81401610780	7,8	7,8	117	75	1	10	19,54
81401610790	7,9	7,9	117	75	1	10	19,54
81401610800	8	8	117	75	1	10	14,79
81401610810	8,1	8,1	117	75	1	5	19,54
81401610820	8,2	8,2	117	75	1	5	19,54
81401610825	8,25	8,25	117	75	1	5	18,61
81401610830	8,3	8,3	117	75	1	5	19,54
81401610840	8,4	8,4	117	75	1	5	19,54
81401610850	8,5	8,5	117	75	1	5	15,41
81401610860	8,6	8,6	125	81	1	5	22,90
81401610870	8,7	8,7	125	81	1	5	22,90
81401610875	8,75	8,75	125	81	1	5	23,79
81401610880	8,8	8,8	125	81	1	5	23,79
81401610890	8,9	8,9	125	81	1	5	23,79
81401610900	9	9	125	81	1	5	19,71
81401610910	9,1	9,1	125	81	1	5	25,44
81401610920	9,2	9,2	125	81	1	5	25,44
81401610925	9,25	9,25	125	81	1	5	26,29
81401610930	9,3	9,3	125	81	1	5	27,97
81401610940	9,4	9,4	125	81	1	5	27,97
81401610950	9,5	9,5	125	81	1	5	20,34
81401610960	9,6	9,6	133	87	1	5	31,38
81401610970	9,7	9,7	133	87	1	5	32,15
81401610975	9,75	9,75	133	87	1	5	31,02
81401610980	9,8	9,8	133	87	1	5	32,21
81401610990	9,9	9,9	133	87	1	5	32,21
81401611000	10	10	133	87	1	5	22,51
81401611010	10,1	10,1	133	87	1	5	36,62
81401611020	10,2	10,2	133	87	1	5	32,21
81401611025	10,25	10,25	133	87	1	5	44,20
81401611030	10,3	10,3	133	87	1	5	43,30
81401611040	10,4	10,4	133	87	1	5	44,27
81401611050	10,5	10,5	133	87	1	5	33,07
81401611060	10,6	10,6	133	87	1	5	39,40
81401611070	10,7	10,7	142	94	1	5	47,01
81401611075	10,75	10,75	142	94	1	5	47,04
81401611080	10,8	10,8	142	94	1	5	37,56
81401611090	10,9	10,9	142	94	1	5	47,13
81401611100	11	11	142	94	1	5	36,47
81401611110	11,1	11,1	142	94	1	5	42,21
81401611120	11,2	11,2	142	94	1	5	49,38
81401611125	11,25	11,25	142	94	1	5	49,40
81401611130	11,3	11,3	142	94	1	5	49,44
81401611140	11,4	11,4	142	94	1	5	49,49
81401611150	11,5	11,5	142	94	1	5	46,64
81401611160	11,6	11,6	142	94	1	5	57,26
81401611170	11,7	11,7	142	94	1	5	75,20
81401611175	11,75	11,75	142	94	1	5	75,24
81401611180	11,8	11,8	142	94	1	5	75,36
81401611190	11,9	11,9	151	101	1	5	63,69
81401611200	12	12	151	101	1	5	50,02
81401611210	12,1	12,1	151	101	1	5	63,66
81401611220	12,2	12,2	151	101	1	5	84,07
81401611225	12,25	12,25	151	101	1	5	84,11
81401611230	12,3	12,3	151	101	1	5	84,16
81401611240	12,4	12,4	151	101	1	5	76,95
81401611250	12,5	12,5	151	101	1	5	62,73
81401611260	12,6	12,6	151	101	1	5	69,77
81401611270	12,7	12,7	151	101	1	5	86,83
81401611275	12,75	12,75	151	101	1	5	86,87
81401611280	12,8	12,8	151	101	1	5	86,93
81401611300	13	13	151	101	1	5	67,81
81401611400	14	14	160	108	1	5	69,31
81401611500	15	15	169	114	1	5	99,74
81401611600	16	16	178	120	1	1	119,63



BROCA HSS SERIE LARGA DIN 340 | TALADRADOS PROFUNDOS <7xd | APLICACIÓN: ACEROS BLANDOS HASTA 400 N/mm²

HSS DRILL LONG SERIES DIN 340 | DEEP DRILLING <7xd | APPLICATION: SOFT STEELS UP TO 400 N/mm²

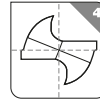
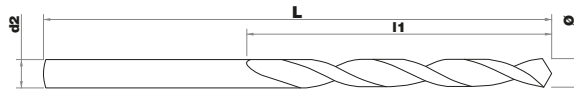

SPLIT POINT



Aceros débilmente aleados <400 N/mm²
Low alloyed steels <400N/mm²

1140561	Ø	d2	L	I1	QTY	PCB	€
11405610100	1	1	56	33	1	10	4,77
11405610120	1,2	1,2	65	41	1	10	4,32
11405610150	1,5	1,5	70	45	1	10	3,40
11405610180	1,8	1,8	80	53	1	10	3,33
11405610200	2	2	85	56	1	10	2,36
11405610220	2,2	2,2	90	59	1	10	2,64
11405610225	2,25	2,25	90	59	1	10	2,64
11405610250	2,5	2,5	95	62	1	10	2,64
11405610275	2,75	2,75	100	66	1	10	2,95
11405610300	3	3	100	66	1	10	2,46
11405610320	3,2	3,2	106	69	1	10	2,66
11405610325	3,25	3,25	106	69	1	10	2,71
11405610330	3,3	3,3	106	69	1	10	2,71
11405610350	3,5	3,5	112	73	1	10	2,71
11405610375	3,75	3,75	112	73	1	10	3,26
11405610380	3,8	3,8	119	78	1	10	3,26
11405610400	4	4	119	78	1	10	2,87
11405610410	4,1	4,1	119	78	1	10	3,50
11405610420	4,2	4,2	119	78	1	10	3,58
11405610425	4,25	4,25	119	78	1	10	3,67
11405610450	4,5	4,5	126	82	1	10	3,28
11405610475	4,75	4,75	126	82	1	10	4,06
11405610480	4,8	4,8	132	87	1	10	4,06
11405610500	5	5	132	87	1	10	3,52
11405610520	5,2	5,2	132	87	1	10	4,38
11405610525	5,25	5,25	132	87	1	10	4,53
11405610550	5,5	5,5	139	91	1	10	4,39
11405610575	5,75	5,75	139	91	1	10	4,98
11405610580	5,8	5,8	139	91	1	10	4,98
11405610600	6	6	139	91	1	10	4,53
11405610625	6,25	6,25	148	97	1	10	5,71
11405610650	6,5	6,5	148	97	1	10	5,72
11405610675	6,75	6,75	156	102	1	10	7,07
11405610680	6,8	6,8	156	102	1	10	7,07
11405610700	7	7	156	102	1	10	6,57
11405610750	7,5	7,5	156	102	1	10	7,05
11405610800	8	8	165	109	1	10	8,20
11405610850	8,5	8,5	165	109	1	5	9,02
11405610900	9	9	175	115	1	5	9,68
11405610950	9,5	9,5	175	115	1	5	10,25
11405611000	10	10	184	121	1	5	10,33
11405611050	10,5	10,5	184	121	1	5	18,06
11405611100	11	11	195	128	1	5	16,73
11405611150	11,5	11,5	195	128	1	5	18,06
11405611200	12	12	205	134	1	5	18,87
11405611250	12,5	12,5	205	134	1	5	19,69
11405611300	13	13	205	134	1	5	20,50



**BROCA ACERO COBALTO 5% (HSSE5) SERIE LARGA DIN 340 |
TALADRADOS PROFUNDOS <7xd | APLICACIÓN: ACEROS SEMI-DUROS
HASTA 700 N/mm², INOXIDABLES**

COBALT DRILL 5% (HSSE5) | LONG SERIE DIN 340 | DEEP DRILLING <7xd |
APPLICATION: SEMI-HARD STEELS UP TO 700 N/mm², STAINLESS STEELS

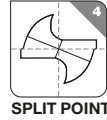
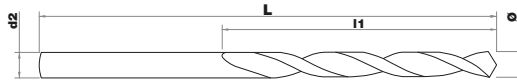

Aceros aleados
200-700 N/mm²
Alloyed steels
200-700N/mm²



Aceros
inoxidables
ferríticos
Ferritic
stainless
steels

1140571	Ø	d2	L	I1	QTY	PCB	€
11405710250	2,5	2,5	95	62	1	10	5,54
11405710300	3	3	100	66	1	10	5,54
11405710350	3,5	3,5	112	73	1	10	6,59
11405710400	4	4	119	78	1	10	6,59
11405710450	4,5	4,5	126	82	1	10	8,40
11405710500	5	5	132	87	1	10	8,40
11405710550	5,5	5,5	139	91	1	10	9,20
11405710600	6	6	139	91	1	10	9,20
11405710650	6,5	6,5	148	97	1	10	11,73
11405710700	7	7	156	102	1	10	12,71
11405710800	8	8	165	109	1	10	14,33
11405710850	8,5	8,5	165	109	1	5	17,68
11405710900	9	9	175	115	1	5	17,68
11405711000	10	10	184	121	1	5	27,74

BROCA HSS SERIE EXTRALARGA | TALADRADOS MUY PROFUNDOS
>10xd | APLICACIÓN: ACEROS BLANDOS HASTA 400 N/mm²

HSS DRILL EXTRA LONG SERIE | VERY DEEP DRILLING >10xd | APPLICATION:
 SOFT STEELS UP TO 400 N/mm²

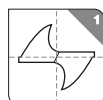
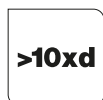
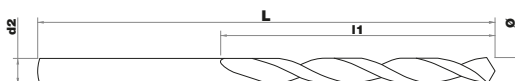

Aceros débilmente
aleados <400 N/mm²
Low alloyed
steels <400N/mm²

1142061	Ø	d2	L	l1	QTY	PCB	€
11420610300	3	3	160	120	1	1	13,33
11420610350	3,5	3,5	160	120	1	1	13,82
11420610400	4	4	160	120	1	1	13,82
11420610450	4,5	4,5	160	120	1	1	14,53
11420610500	5	5	160	120	1	1	14,93
11420610550	5,5	5,5	160	120	1	1	16,23
11420610600	6	6	160	120	1	1	17,16

1142071	Ø	d2	L	l1	QTY	PCB	€
11420710300	3	3	200	150	1	1	17,28
11420710350	3,5	3,5	200	150	1	1	17,98
11420710400	4	4	200	150	1	1	18,21
11420710450	4,5	4,5	200	150	1	1	19,24
11420710500	5	5	200	150	1	1	19,45
11420710550	5,5	5,5	200	150	1	1	21,21
11420710600	6	6	200	150	1	1	21,68
11420710650	6,5	6,5	200	150	1	1	23,33
11420710700	7	7	200	150	1	1	24,92
11420710750	7,5	7,5	200	150	1	1	26,29
11420710800	8	8	200	150	1	1	28,78
11420710850	8,5	8,5	200	150	1	1	30,07
11420710900	9	9	200	150	1	1	31,23
11420710950	9,5	9,5	200	150	1	1	33,07
11420711000	10	10	200	150	1	1	34,35

1142081	Ø	d2	L	l1	QTY	PCB	€
11420810350	3,5	3,5	250	187	1	1	21,59
11420810400	4	4	250	187	1	1	21,59
11420810450	4,5	4,5	250	187	1	1	23,11
11420810500	5	5	250	187	1	1	24,44
11420810550	5,5	5,5	250	187	1	1	25,63
11420810600	6	6	250	187	1	1	26,10
11420810650	6,5	6,5	250	187	1	1	28,91
11420810700	7	7	250	187	1	1	30,39
11420810750	7,5	7,5	250	187	1	1	32,19
11420810800	8	8	250	187	1	1	32,63
11420810850	8,5	8,5	250	187	1	1	34,76
11420810900	9	9	250	187	1	1	36,70
11420810950	9,5	9,5	250	187	1	1	37,92
11420811000	10	10	250	187	1	1	38,83
11420811050	10,5	10,5	250	187	1	1	40,23
11420811100	11	11	250	187	1	1	42,28
11420811150	11,5	11,5	250	187	1	1	47,19
11420811200	12	12	250	187	1	1	48,78
11420811250	12,5	12,5	250	187	1	1	53,91
11420811300	13	13	250	187	1	1	55,27



1142091	Ø	d2	L	I1	QTY	PCB	€
11420910400	4	4	315	235	1	1	26,35
11420910450	4,5	4,5	315	235	1	1	28,49
11420910500	5	5	315	235	1	1	30,05
11420910550	5,5	5,5	315	235	1	1	32,74
11420910600	6	6	315	235	1	1	34,46
11420910650	6,5	6,5	315	235	1	1	36,70
11420910700	7	7	315	235	1	1	38,67
11420910750	7,5	7,5	315	235	1	1	40,33
11420910800	8	8	315	235	1	1	41,52
11420910850	8,5	8,5	315	235	1	1	43,78
11420910900	9	9	315	235	1	1	45,48
11420910950	9,5	9,5	315	235	1	1	47,04
11420911000	10	10	315	235	1	1	47,65
11420911050	10,5	10,5	315	235	1	1	50,33
11420911100	11	11	315	235	1	1	51,06
11420911150	11,5	11,5	315	235	1	1	53,70
11420911200	12	12	315	235	1	1	54,39
11420911250	12,5	12,5	315	235	1	1	57,57
11420911300	13	13	315	235	1	1	60,98

1142101	Ø	d2	L	I1	QTY	PCB	€
11421010500	5	5	400	300	1	1	39,73
11421010550	5,5	5,5	400	300	1	1	39,73
11421010600	6	6	400	300	1	1	39,03
11421010650	6,5	6,5	400	300	1	1	42,93
11421010700	7	7	400	300	1	1	45,70
11421010750	7,5	7,5	400	300	1	1	48,93
11421010800	8	8	400	300	1	1	50,81
11421010850	8,5	8,5	400	300	1	1	54,31
11421010900	9	9	400	300	1	1	56,96
11421010950	9,5	9,5	400	300	1	1	59,51
11421011000	10	10	400	300	1	1	60,86
11421011050	10,5	10,5	400	300	1	1	65,34
11421011100	11	11	400	300	1	1	68,38
11421011150	11,5	11,5	400	300	1	1	71,44
11421011200	12	12	400	300	1	1	73,10
11421011250	12,5	12,5	400	300	1	1	77,80
11421011300	13	13	400	300	1	1	81,28



**BROCA HSS MANGO CÓNICO | SERIE CORTA DIN 345 |
TALADRADOS DE PROFUNDIDAD MEDIA <3xd |
APLICACIÓN ACEROS BLANDOS HASTA 400 N/mm²**

HSS MORSE TAPER SHANK DRILL DIN 345 | MEDIUM DEEP DRILLING <3xd |
APPLICATION: SOFT STEELS UP TO 400 N/mm²

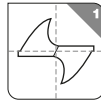
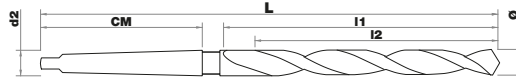

Aceros débilmente
aleados <400 N/mm²
Low alloyed
steels <400N/mm²

1143791	Ø	CM	L	I1	QTY	PCB	€
11437911000	10	CM1	168	87	1	1	15,21
11437911050	10,5	CM1	168	87	1	1	16,29
11437911100	11	CM1	175	94	1	1	16,51
11437911150	11,5	CM1	175	94	1	1	16,51
11437911200	12	CM1	182	101	1	1	16,74
11437911250	12,5	CM1	182	101	1	1	17,59
11437911300	13	CM1	182	101	1	1	16,99
11437911350	13,5	CM1	189	108	1	1	18,87
11437911400	14	CM1	189	108	1	1	18,87
11437911450	14,5	CM2	212	114	1	1	21,74
11437911500	15	CM2	212	114	1	1	25,26
11437911550	15,5	CM2	218	120	1	1	25,26
11437911600	16	CM2	218	120	1	1	24,79
11437911650	16,5	CM2	223	125	1	1	28,12
11437911700	17	CM2	223	125	1	1	26,66
11437911750	17,5	CM2	228	130	1	1	29,38
11437911800	18	CM2	228	130	1	1	31,30
11437911850	18,5	CM2	233	135	1	1	33,01
11437911900	19	CM2	233	135	1	1	32,14
11437911950	19,5	CM2	238	140	1	1	36,61
11437912000	20	CM2	238	140	1	1	34,43
11437912050	20,5	CM2	243	145	1	1	40,00
11437912100	21	CM2	243	145	1	1	40,85
11437912150	21,5	CM2	248	150	1	1	44,54
11437912200	22	CM2	248	150	1	1	44,06
11437912250	22,5	CM2	253	155	1	1	47,87
11437912300	23	CM2	253	155	1	1	51,09
11437912350	23,5	CM3	276	155	1	1	49,18
11437912400	24	CM3	281	160	1	1	51,51
11437912450	24,5	CM3	281	160	1	1	53,62
11437912500	25	CM3	281	160	1	1	48,83
11437912550	25,5	CM3	286	165	1	1	60,32
11437912600	26	CM3	286	165	1	1	61,18
11437912650	26,5	CM3	286	165	1	1	61,65
11437912700	27	CM3	291	170	1	1	66,54
11437912750	27,5	CM3	291	170	1	1	67,45
11437912800	28	CM3	291	170	1	1	69,67
11437912850	28,5	CM3	296	175	1	1	78,61
11437912900	29	CM3	296	175	1	1	75,04
11437912950	29,5	CM3	296	175	1	1	77,74
11437913000	30	CM3	296	175	1	1	80,87
11437913050	30,5	CM3	301	180	1	1	97,34
11437913100	31	CM3	301	180	1	1	91,19
11437913150	31,5	CM3	301	180	1	1	102,76
11437913200	32	CM4	334	185	1	1	96,47
11437913300	33	CM4	334	185	1	1	103,70
11437913400	34	CM4	339	190	1	1	116,39
11437913500	35	CM4	344	195	1	1	115,26
11437913600	36	CM4	344	195	1	1	129,58
11437913700	37	CM4	344	195	1	1	133,94
11437913800	38	CM4	349	200	1	1	147,38
11437913900	39	CM4	349	200	1	1	150,98
11437914000	40	CM4	349	200	1	1	166,16

**BROCA HSS MANGO CÓNICO | SERIE CORTA DIN 345 |
TALADRADOS DE PROFUNDIDAD MEDIA <3xd | APLICACIÓN:
ACEROS SEMI-DUROS HASTA 700 N/mm²**

HSS MORSE TAPER SHANK DRILL DIN 345 | MEDIUM DEEP <3xd |
APPLICATION: SEMI-HARD STEELS UP TO 700 N/mm²

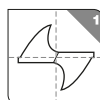
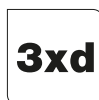
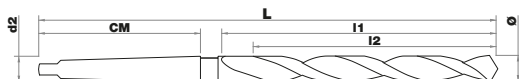

Aceros aleados
200-700 N/mm²
Alloyed steels
200-700N/mm²

1140981	Ø	CM	L	I1	QTY	PCB	€
11409810300	3	CM1	114	33	1	1	29,78
11409810350	3,5	CM1	120	39	1	1	31,37
11409810400	4	CM1	124	43	1	1	28,21
11409810420	4,2	CM1	124	43	1	1	40,51
11409810450	4,5	CM1	128	47	1	1	26,98
11409810500	5	CM1	133	52	1	1	25,01
11409810520	5,2	CM1	133	52	1	1	42,06
11409810550	5,5	CM1	138	57	1	1	26,24
11409810600	6	CM1	138	57	1	1	24,64
11409810620	6,2	CM1	144	63	1	1	42,06
11409810650	6,5	CM1	144	63	1	1	24,22
11409810670	6,7	CM1	144	63	1	1	42,06
11409810675	6,75	CM1	150	69	1	1	24,22
11409810680	6,8	CM1	150	69	1	1	42,06
11409810700	7	CM1	150	69	1	1	23,02
11409810750	7,5	CM1	150	69	1	1	26,24
11409810800	8	CM1	156	75	1	1	23,25
11409810850	8,5	CM1	156	75	1	1	26,98
11409810880	8,8	CM1	162	81	1	1	35,32
11409810900	9	CM1	162	81	1	1	27,79
11409810950	9,5	CM1	162	81	1	1	29,78
11409810975	9,75	CM1	168	87	1	1	46,81
11409810980	9,8	CM1	168	87	1	1	46,81
11409811000	10	CM1	168	87	1	1	30,92
11409811020	10,2	CM1	168	87	1	1	38,51
11409811025	10,25	CM1	168	87	1	1	38,29
11409811050	10,5	CM1	168	87	1	1	37,40
11409811075	10,75	CM1	175	94	1	1	45,08
11409811100	11	CM1	175	94	1	1	38,45
11409811150	11,5	CM1	175	94	1	1	38,72
11409811175	11,75	CM1	175	94	1	1	59,05
11409811200	12	CM1	182	101	1	1	38,65
11409811250	12,5	CM1	182	101	1	1	35,12
11409811270	12,7	CM1	182	101	1	1	43,39
11409811275	12,75	CM1	182	101	1	1	40,30
11409811300	13	CM1	182	101	1	1	34,83
11409811325	13,25	CM1	189	108	1	1	48,33
11409811350	13,5	CM1	189	108	1	1	42,48
11409811375	13,75	CM1	189	108	1	1	56,96
11409811400	14	CM1	189	108	1	1	36,04
11409811410	14,1	CM2	212	114	1	1	56,81
11409811425	14,25	CM2	212	114	1	1	51,52
11409811450	14,5	CM2	212	114	1	1	46,76
11409811475	14,75	CM2	212	114	1	1	59,85
11409811500	15	CM2	212	114	1	1	46,79
11409811525	15,25	CM2	218	120	1	1	58,17
11409811550	15,5	CM2	218	120	1	1	48,42
11409811575	15,75	CM2	218	120	1	1	60,20
11409811600	16	CM2	218	120	1	1	47,46
11409811625	16,25	CM2	223	125	1	1	56,13
11409811650	16,5	CM2	223	125	1	1	52,10
11409811675	16,75	CM2	223	125	1	1	55,32
11409811700	17	CM2	223	125	1	1	49,40

	1140981	Ø	CM	L	I1	QTY	PCB	€
	11409811720	17,2	CM2	228	130	1	1	80,49
	11409811750	17,5	CM2	228	130	1	1	54,43
	11409811775	17,75	CM2	228	130	1	1	56,81
	11409811800	18	CM2	228	130	1	1	58,00
	11409811825	18,25	CM2	233	135	1	1	65,55
	11409811850	18,5	CM2	233	135	1	1	61,15
	11409811875	18,75	CM2	233	135	1	1	66,51
	11409811900	19	CM2	233	135	1	1	59,51
	11409811925	19,25	CM2	238	140	1	1	67,81
	11409811950	19,5	CM2	238	140	1	1	67,81
	11409811975	19,75	CM2	238	140	1	1	68,77
	11409812000	20	CM2	238	140	1	1	63,79
	11409812025	20,25	CM2	243	145	1	1	82,06
	11409812050	20,5	CM2	243	145	1	1	74,10
	11409812075	20,75	CM2	243	145	1	1	78,89
	11409812100	21	CM2	243	145	1	1	75,70
	11409812150	21,5	CM2	248	150	1	1	82,47
	11409812200	22	CM2	248	150	1	1	81,59
	11409812250	22,5	CM2	253	155	1	1	88,67
	11409812300	23	CM2	253	155	1	1	94,70
	11409812350	23,5	CM3	276	155	1	1	91,09
	11409812400	24	CM3	281	160	1	1	95,41
	11409812450	24,5	CM3	281	160	1	1	99,32
	11409812500	25	CM3	281	160	1	1	90,48
	11409812550	25,5	CM3	286	165	1	1	111,73
	11409812575	25,75	CM3	286	165	1	1	128,25
	11409812600	26	CM3	286	165	1	1	113,32
	11409812650	26,5	CM3	286	165	1	1	114,21
	11409812700	27	CM3	291	170	1	1	123,24
	11409812750	27,5	CM3	291	170	1	1	124,93
	11409812800	28	CM3	291	170	1	1	129,14
	11409812850	28,5	CM3	296	175	1	1	145,59
	11409812900	29	CM3	296	175	1	1	139,06
	11409812950	29,5	CM3	296	175	1	1	143,98
	11409813000	30	CM3	296	175	1	1	149,77
	11409813050	30,5	CM3	301	180	1	1	180,35
	11409813100	31	CM3	301	180	1	1	168,90
	11409813150	31,5	CM3	301	180	1	1	190,37
	11409813200	32	CM4	334	185	1	1	178,76
	11409813250	32,5	CM4	334	185	1	1	208,61
	11409813300	33	CM4	334	185	1	1	192,10
	11409813350	33,5	CM4	334	185	1	1	221,80
	11409813400	34	CM4	339	190	1	1	215,59
	11409813450	34,5	CM4	339	190	1	1	254,98
	11409813500	35	CM4	339	190	1	1	213,52
	11409813550	35,5	CM4	339	190	1	1	251,45
	11409813600	36	CM4	344	195	1	1	240,05
	11409813650	36,5	CM4	344	195	1	1	266,38
	11409813700	37	CM4	344	195	1	1	248,16
	11409813750	37,5	CM4	344	195	1	1	287,83
	11409813800	38	CM4	349	200	1	1	273,06
	11409813850	38,5	CM4	349	200	1	1	344,48
	11409813900	39	CM4	349	200	1	1	279,72
	11409813950	39,5	CM4	349	200	1	1	344,48
	11409814000	40	CM4	349	200	1	1	307,85
	11409814050	40,5	CM4	354	205	1	1	384,19
	11409814100	41	CM4	354	205	1	1	364,16
	11409814200	42	CM4	354	205	1	1	380,69
	11409814300	43	CM4	359	210	1	1	407,02
	11409814400	44	CM4	359	210	1	1	421,95
	11409814500	45	CM4	359	210	1	1	438,47
	11409814600	46	CM4	364	215	1	1	446,73
	11409814700	47	CM4	364	215	1	1	463,57
	11409814800	48	CM4	369	220	1	1	496,25
	11409814900	49	CM4	369	220	1	1	513,08
	11409815000	50	CM4	369	220	1	1	537,85
	11409815100	51	CM5	412	225	1	1	634,65
	11409815200	52	CM5	412	225	1	1	666,44
	11409815300	53	CM5	412	225	1	1	666,44
	11409815400	54	CM5	417	230	1	1	714,05
	11409815500	55	CM5	417	230	1	1	730,23
	11409815600	56	CM5	417	230	1	1	730,23
	11409815700	57	CM5	422	235	1	1	785,43
	11409815800	58	CM5	422	235	1	1	825,14
	11409815900	59	CM5	422	235	1	1	825,14
	11409816000	60	CM5	422	235	1	1	856,89

**BROCA ACERO COBALTO 5% (HSSE5) MANGO CÓNICO | SERIE CORTA
DIN 345 | TALADRADOS DE PROFUNDIDAD MEDIA <3xd | APLICACIÓN:
ACEROS SEMI-DUROS HASTA 700 N/mm², INOXIDABLES**

COBALT DRILL 5% (HSSE5) MORSE TAPER SHANK DIN 345 | MEDIUM DEEP
DRILLING <3xd | APPLICATION: SEMI-HARD STEELS UP TO 700 N/mm² AND
STAINLESS STEELS

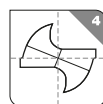
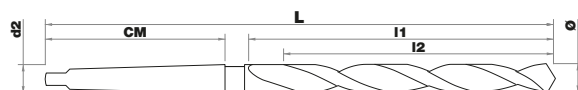

SPLIT POINT



Aceros aleados
200-700 N/mm²
Alloyed steels
200-700N/mm²



Aceros
inoxidables
ferríticos
Ferritic
stainless
steels

1141051	Ø	CM	L	I1	QTY	PCB	€
11410511000	10	CM1	168	87	1	1	73,01
11410511050	10,5	CM1	168	87	1	1	76,18
11410511100	11	CM1	175	94	1	1	73,01
11410511150	11,5	CM1	175	94	1	1	76,18
11410511200	12	CM1	182	101	1	1	78,08
11410511250	12,5	CM1	182	101	1	1	82,66
11410511300	13	CM1	182	101	1	1	80,21
11410511350	13,5	CM1	189	108	1	1	104,80
11410511400	14	CM1	189	108	1	1	102,77
11410511450	14,5	CM2	212	114	1	1	114,11
11410511500	15	CM2	212	114	1	1	104,80
11410511550	15,5	CM2	218	120	1	1	116,14
11410511600	16	CM2	218	120	1	1	112,04
11410511650	16,5	CM2	223	125	1	1	117,17
11410511700	17	CM2	223	125	1	1	113,03
11410511750	17,5	CM2	228	130	1	1	123,36
11410511800	18	CM2	228	130	1	1	121,27
11410511850	18,5	CM2	233	135	1	1	132,58
11410511900	19	CM2	233	135	1	1	129,51
11410511950	19,5	CM2	238	140	1	1	149,03
11410512000	20	CM2	238	140	1	1	144,89
11410512050	20,5	CM2	243	145	1	1	166,47
11410512100	21	CM2	243	145	1	1	168,55
11410512150	21,5	CM2	248	150	1	1	190,17
11410512200	22	CM2	248	150	1	1	171,53
11410512250	22,5	CM2	253	155	1	1	211,68
11410512300	23	CM2	253	155	1	1	199,49
11410512350	23,5	CM3	276	155	1	1	211,68
11410512400	24	CM3	281	160	1	1	213,76
11410512450	24,5	CM3	281	160	1	1	228,25
11410512500	25	CM3	281	160	1	1	225,81
11410512550	25,5	CM3	286	165	1	1	279,60
11410512600	26	CM3	286	165	1	1	265,00
11410512650	26,5	CM3	286	165	1	1	293,90
11410512700	27	CM3	291	170	1	1	293,90
11410512750	27,5	CM3	291	170	1	1	351,52
11410512800	28	CM3	291	170	1	1	325,19
11410512850	28,5	CM3	296	175	1	1	359,74
11410512900	29	CM3	296	175	1	1	332,41
11410513000	30	CM3	296	175	1	1	339,48
11410513100	31	CM3	301	180	1	1	398,28
11410513200	32	CM4	334	185	1	1	430,25
11410513400	34	CM4	339	190	1	1	559,93
11410513500	35	CM4	339	190	1	1	533,43
11410513600	36	CM4	344	195	1	1	646,59
11410513700	37	CM4	344	195	1	1	675,48
11410513800	38	CM4	349	200	1	1	774,51
11410513900	39	CM4	349	200	1	1	804,08
11410514000	40	CM4	349	200	1	1	778,62

CASQUILLO DE REDUCCIÓN TEMPLADO | CONOS INTERIORES Y EXTERIORES RECTIFICADOS

TEMPERED ADAPTER | RECTIFIED INTERIOR AND EXTERIOR CONES



**DIN
2185**

1110341	CE	CI	L	QTY	PCB	€
11103410201	2	1	92	1	1	14,92
11103410301	3	1	99	1	1	18,62
11103410302	3	2	112	1	1	18,62
11103410402	4	2	124	1	1	24,78
11103410403	4	3	140	1	1	24,78
11103410504	5	4	171	1	1	43,41

CASQUILLO DE REDUCCIÓN LARGO TEMPLADO | CONOS INTERIORES Y EXTERIORES RECTIFICADOS

TEMPERED ELONGATED ADAPTER | RECTIFIED INTERIOR AND EXTERIOR CONES

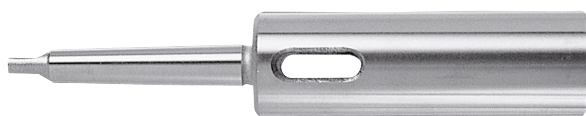

**DIN
2187**

1110361	CE	CI	L	QTY	PCB	€
11103610201	2	1	160	1	1	62,73
11103610202	2	2	175	1	1	78,92
11103610203	2	3	196	1	1	109,12
11103610302	3	2	194	1	1	78,92
11103610304	3	4	240	1	1	174,68
11103610405	4	5	300	1	1	294,65

EXTRACTOR DE CONOS

CONE PUNCH



**TIVOLY
NORM**

1110371	CM	QTY	PCB	€
11103710102	1/2	1	1	6,84
11103710203	2/3	1	1	11,42
11103710304	3/4	1	1	12,59

**BROCA HSS ESCALONADA | CANAL RECTO | APLICACIÓN:
TALADRADO DE CHAPAS <3mm Y PLÁSTICOS**

HSS STEP DRILL | STRAIGHT FLUTE | APPLICATION: METAL SHEET <3mm AND PLASTICS

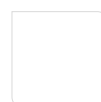
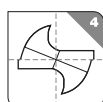
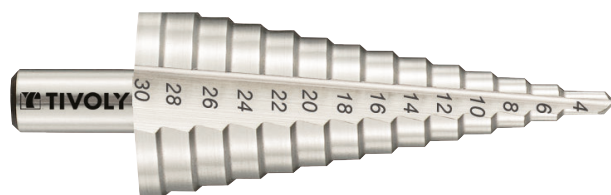

SPLIT POINT



Metal
Metal

1 144862	Ø	d1	d2	d3	L	QTY	PCB	€
11448620412	4>12	12	6	4	65	1	1	26,13
11448620420	4>20	20	8	4	75	1	1	34,46
11448620430	4>30	30	10	4	100	1	1	58,47
11448620637	6>37	37	10	6	100	1	1	83,08

ESTUCHE DE BROCAS ESCALONADAS HSS | CANAL RECTO

HSS STEP DRILL SET | STRAIGHT FLUTE



1 1448670001		
COMPOSICIÓN	PCB	€
4-12mm 4-20mm 4-30mm	1	118,99



BROCA HSS ESCALONADA | CANAL HELICOIDAL | APLICACIÓN:

TALADRADO DE CHAPAS <3mm Y PLÁSTICOS

HSS STEP DRILL | HELICOIDAL FLUTE | APPLICATION: METAL SHEET <3mm AND PLASTICS

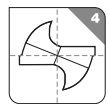
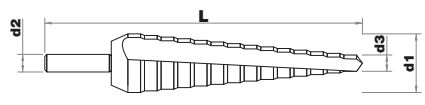

SPLIT POINT



Metal
Metal



Fundiciones
Cast Iron

1144852	Ø	d1	d2	d3	L	QTY	PCB	€
11448520412	4>12	12	6	4	65	1	1	35,49
11448520420	4>20	20	8	4	75	1	1	45,33
11448520430	4>30	30	10	4	100	1	1	65,67
11448520637	6>37	37	10	6	100	1	1	104,22



ESTUCHE DE BROCAS ESCALONADAS HSS | CANAL HELICOIDAL

HSS STEP DRILL SET | HELICOIDAL FLUTE



11448570001		
COMPOSICIÓN	PCB	€
4-12mm 4-20mm 4-30mm	1	146,49

**BROCA HSS ESCALONADA TiAlN | CANAL HELICOIDAL | APLICACIÓN:
TALADRADO DE CHAPAS <3mm Y PLÁSTICOS**

HSS STEP DRILL TiAlN | HELICOIDAL FLUTE | APPLICATION: METAL SHEET <3mm AND PLASTICS

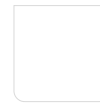
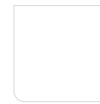
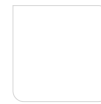
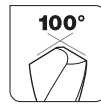
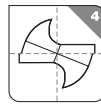
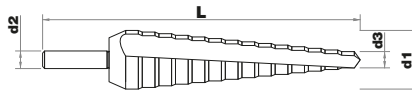

Metal
Metal



Fundiciones
Cast Iron

1143872	Ø	d1	d2	d3	L	QTY	PCB	€
11438720412	4>12	12	6	4	65	1	1	50,28
11438720420	4>20	20	8	4	75	1	1	64,22
11438720430	4>30	30	10	4	100	1	1	111,10
11438720637	6>37	37	10	6	100	1	1	176,31

**ESTUCHE DE BROCAS ESCALONADAS HSS TiAlN |
CANAL HELICOIDAL**

HSS STEP DRILL TiAlN SET | HELICOIDAL FLUTE



11438770001		
COMPOSICIÓN	PCB	€
4-12mm 4-20mm 4-30mm	1	226,73

BROCA ESCALONADA ACERO COBALTO 5% (HSSE5) TiAlN | CANAL HELICOIDAL | APLICACIÓN: TALADRADO DE CHAPAS <3mm Y PLÁSTICOS

HSSE5 STEP DRILL TiAlN | HELICOIDAL FLUTE | APPLICATION: METAL SHEET <3mm AND PLASTICS

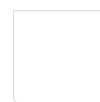
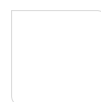
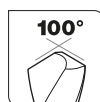
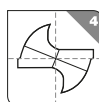
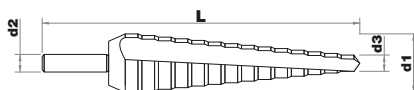

Metal
Metal



Fundiciones
Cast Iron



Aceros
inoxidables
Stainless
Steel

1144872	Ø	d1	d2	d3	L	QTY	PCB	€
11448720412	4>12	12	6	4	65	1	1	70,40
11448720420	4>20	20	8	4	75	1	1	89,91
11448720430	4>30	30	10	4	100	1	1	155,56
11448720637	6>37	37	10	6	100	1	1	246,85

ESTUCHE DE BROCAS ESCALONADAS HSSE5 TiAlN | CANAL HELICOIDAL

HSSE5 STEP DRILL TiAlN SET | HELICOIDAL FLUTE



11448770001		
COMPOSICIÓN	PCB	€
4-12mm 4-20mm 4-30mm	1	318,08

**BROCA PARA PUNTEAR 90° ACERO COBALTO 5% (HSSE5) | APLICACIÓN:
ACEROS SEMI-DUROS HASTA 700 N/mm²**
SPOTTING DRILL 90° COBALT DRILL 5% (HSSE5) | APPLICATION: SEMI-HARD
STEELS UP TO 700 N/mm²

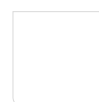
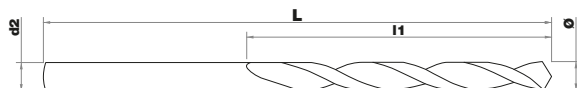
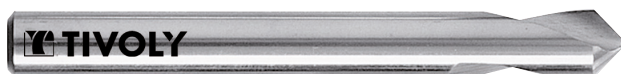

Aceros débilmente aleados <400 N/mm²
Low alloyed steels <400N/mm²



Aceros aleados y tratados < 700N/mm²
Heat Treatable Steels <700N/mm²

8140891	Ø	d2	L	l1	QTY	PCB	€
81408910300	3	3	50	10	1	1	22,14
81408910400	4	4	52	12	1	1	22,14
81408910500	5	5	60	15	1	1	24,95
81408910600	6	6	66	20	1	1	24,95
81408910800	8	8	79	25	1	1	28,12
81408911000	10	10	89	25	1	1	28,27
81408911200	12	12	102	30	1	1	38,98
81408911600	16	16	115	35	1	1	53,70
81408912000	20	20	131	40	1	1	105,62
8140911	Ø	d2	L	l1	QTY	PCB	€
81409110300	3	3	50	10	1	1	22,14
81409110400	4	4	52	12	1	1	22,14
81409110500	5	5	60	15	1	1	24,95
81409110600	6	6	66	20	1	1	24,95
81409110800	8	8	79	25	1	1	28,12
81409111000	10	10	89	25	1	1	28,12
81409111200	12	12	102	30	1	1	38,98
81409111600	16	16	115	35	1	1	53,70
81409112000	20	20	131	40	1	1	105,62



**BROCA DE CENTRAR 60° HSS DIN 333A. FORMA A | APLICACIÓN:
ACEROS BLANDOS HASTA 400 N/mm²**

60° CENTER DRILL HSS | A FORM | APPLICATION: SOFT STEELS UP TO
400 N/mm²

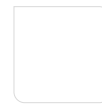
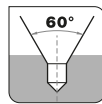
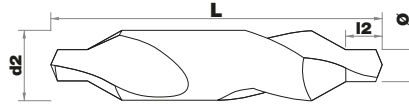

Aceros débilmente
aleados <400 N/mm²
Low alloyed
steels <400N/mm²

8140811	Ø	d2	L	QTY	PCB	€
8140811050315	3,15	0,5	25	1	1	9,91
8140811063315	3,15	0,63	25	1	1	9,91
8140811080315	3,15	0,8	25	1	1	9,91
8140811100315	3,15	1	31	1	1	9,91
8140811100400	4	1	35	1	1	9,91
8140811125315	3,15	1,25	31	1	1	9,91
8140811150500	5	1,5	40	1	1	10,72
8140811160400	4	1,6	35	1	1	9,91
8140811200500	5	2	40	1	1	10,72
8140811200600	6	2	45	1	1	11,90
8140811250630	6,3	2,5	45	1	1	11,90
8140811250800	8	2,5	50	1	1	13,13
8140811300100	10	3	55	1	1	17,06
8140811300800	8	3	50	1	1	13,13
8140811315800	8	3,15	50	1	1	13,13
8140811400100	10	4	55	1	1	17,06
8140811400120	12	4	63	1	1	28,58
8140811500120	12	5	63	1	1	28,58
8140811500125	12,5	5	63	1	1	28,58
8140811500140	14	5	71	1	1	36,07
8140811600180	18	6	80	1	1	55,90
8140811630160	16	6,3	71	1	1	40,86
8140811800200	20	8	80	1	1	76,52





■ **BROCAS METAL DURO 70**
CARBIDE BITS



**BROCA METAL DURO TiAlN DIN 6537K | SIN REFRIGERACIÓN
INTERNA | TALADRADOS DE PROFUNDIDAD <3xd | APLICACIÓN:
ACEROS MUY DUROS HASTA 1400 N/mm²**

HM DRILL WITH TiAlN DIN 6537K | WITHOUT COOLANT FEED | DEEP DRILLING
<3xd | APPLICATION: VERY HARD STEELS UP TO 1400 N/mm²

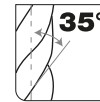
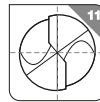
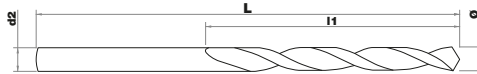

Aceros aleados
200-700 N/mm²
Alloyed steels
200-700N/mm²



Aceros aleados
y tratados
700-1400 N/mm²
Heat treatables steels
700-1400N/mm²



Funciones
Cast iron

8241501	Ø	d2	L	I1	QTY	PCB	€
82415010300	3	6	62	20	1	1	31,64
82415010330	3,3	6	62	20	1	1	31,64
82415010350	3,5	6	62	20	1	1	31,64
82415010400	4	6	66	24	1	1	31,64
82415010420	4,2	6	66	24	1	1	31,64
82415010450	4,5	6	66	24	1	1	31,64
82415010500	5	6	66	28	1	1	31,64
82415010550	5,5	6	66	28	1	1	31,64
82415010600	6	6	66	28	1	1	31,64
82415010650	6,5	8	79	34	1	1	31,64
82415010675	6,75	8	79	34	1	1	31,64
82415010680	6,8	8	79	34	1	1	31,64
82415010700	7	8	79	34	1	1	31,64
82415010750	7,5	8	79	41	1	1	31,64
82415010800	8	8	79	41	1	1	31,64
82415010850	8,5	8	79	41	1	1	31,64
82415010900	9	10	89	47	1	1	35,49
82415010950	9,5	10	89	47	1	1	35,49
82415011000	10	10	89	47	1	1	35,49
82415011020	10,2	12	102	55	1	1	52,87
82415011050	10,5	12	102	55	1	1	52,87
82415011100	11	12	102	55	1	1	52,87
82415011150	11,5	12	102	55	1	1	52,87
82415011200	12	12	102	55	1	1	52,87
82415011250	12,5	14	107	60	1	1	70,98
82415011300	13	14	107	60	1	1	70,98
82415011350	13,5	14	107	60	1	1	70,98
82415011400	14	14	107	60	1	1	70,98
82415011450	14,5	16	115	65	1	1	91,60
82415011500	15	16	115	65	1	1	91,60
82415011550	15,5	16	115	65	1	1	91,60
82415011600	16	16	115	65	1	1	91,60



**BROCA METAL DURO TiALN DIN 6537K | CON REFRIGERACIÓN INTERNA
| TALADRADOS DE PROFUNDIDAD <5xd | APLICACIÓN: ACEROS DUROS
HASTA 1400 N/mm², ACEROS INOXIDABLES, FUNDICIÓN**

HM DRILL WITH TiALN DIN 6537K | COOLANT FEED | DEEP DRILLING <5xd |
APPLICATION: VERY HARD STEELS UP TO 1400 N/mm² AND STAINLESS
STEELS, CAST IRON

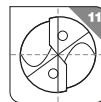
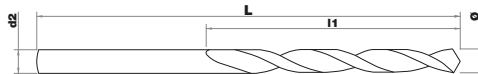

Aceros aleados
200-700 N/mm²
Alloyed steels
200-700N/mm²



Aceros aleados
y tratados
700-1400 N/mm²
Heat treatables steels
700-1400N/mm²



Aceros
inoxidables
Stainless
Steels



Fundiciones
Cast iron

8241701	Ø	d2	L	I1	QTY	PCB	€
82417010400	4	6	74	36	1	1	55,46
82417010420	4,2	6	74	36	1	1	55,46
82417010450	4,5	6	74	36	1	1	55,46
82417010500	5	6	82	44	1	1	55,46
82417010550	5,5	6	82	44	1	1	55,46
82417010600	6	6	82	44	1	1	55,46
82417010650	6,5	8	91	53	1	1	61,31
82417010675	6,75	8	91	53	1	1	61,31
82417010680	6,8	8	91	53	1	1	61,31
82417010700	7	8	91	53	1	1	61,31
82417010750	7,5	8	91	53	1	1	61,31
82417010800	8	8	91	53	1	1	61,31
82417010850	8,5	10	103	61	1	1	70,36
82417010900	9	10	103	61	1	1	70,36
82417010950	9,5	10	103	61	1	1	70,36
82417011000	10	10	103	61	1	1	70,36
82417011020	10,2	12	118	71	1	1	102,64
82417011050	10,5	12	118	71	1	1	102,64
82417011100	11	12	118	71	1	1	102,64
82417011150	11,5	12	118	71	1	1	102,64
82417011200	12	12	118	71	1	1	102,64
82417011250	12,5	14	124	77	1	1	138,14
82417011300	13	14	124	77	1	1	138,14
82417011350	13,5	14	124	77	1	1	138,14
82417011400	14	14	124	77	1	1	138,14
82417011450	14,5	16	133	83	1	1	170,39
82417011500	15	16	133	83	1	1	170,39
82417011550	15,5	16	133	83	1	1	170,39
82417011600	16	16	133	83	1	1	170,39
82417011650	16,5	18	143	93	1	1	273,04
82417011700	17	18	143	93	1	1	273,04
82417011750	17,5	18	143	93	1	1	273,04
82417011800	18	18	143	93	1	1	273,04
82417011850	18,5	20	153	101	1	1	296,85
82417011900	19	20	153	101	1	1	296,85
82417011950	19,5	20	153	101	1	1	296,85
82417012000	20	20	153	101	1	1	296,85



**BROCA METAL DURO MONOBLOC SIM. DIN 338 | SERIE CORTA |
TALADRADOS DE PROFUNDIDAD MEDIA <3xd | APLICACIÓN: ACEROS
DUROS HASTA 1400 N/mm², ACEROS INOXIDABLES, FUNDICIÓN**

SOLID CARBIDE JOBBER LENGTH DRILL SIM. DIN 338 | MEDIUM DEEP
DRILLING <3xd | APPLICATION: VERY HARD STEELS UP TO 1200 N/mm² AND
STAINLESS STEELS, CAST IRON

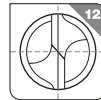
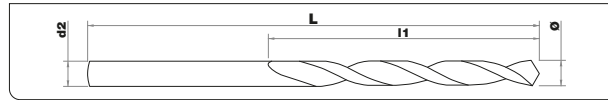

Aceros aleados
200-700 N/mm²
Alloyed steels
200-700N/mm²



Aceros aleados
y tratados
700-1400 N/mm²
Heat treatables steels
700-1400N/mm²



Aceros
inoxidables
Stainless
Steels



Fundiciones
Cast iron



Aleaciones
de aluminio
Aluminium
alloys



Aleaciones
refractarias Co
/ Ni y Titanio
Ni / Co based
special alloys &
Titanium

	8243921	Ø	d2	L	l1	QTY	PCB	€
	82439210100	1	1	34	12	1	1	6,95
	82439210110	1,1	1,1	36	14	1	1	7,37
	82439210120	1,2	1,2	38	16	1	1	7,69
	82439210130	1,3	1,3	38	16	1	1	8,13
	82439210140	1,4	1,4	40	18	1	1	8,75
	82439210150	1,5	1,5	40	18	1	1	8,89
	82439210160	1,6	1,6	43	20	1	1	9,02
	82439210170	1,7	1,7	43	20	1	1	9,18
	82439210180	1,8	1,8	46	22	1	1	10,37
	82439210190	1,9	1,9	46	22	1	1	10,37
	82439210200	2	2	49	24	1	1	10,55
	82439210210	2,1	2,1	49	24	1	1	11,29
	82439210220	2,2	2,2	53	27	1	1	12,49
	82439210230	2,3	2,3	53	27	1	1	12,49
	82439210240	2,4	2,4	57	30	1	1	13,71
	82439210250	2,5	2,5	57	30	1	1	12,36
	82439210260	2,6	2,6	57	30	1	1	14,01
	82439210270	2,7	2,7	61	33	1	1	16,12
	82439210280	2,8	2,8	61	33	1	1	16,42
	82439210290	2,9	2,9	61	33	1	1	16,12
	82439210300	3	3	61	33	1	1	15,06
	82439210310	3,1	3,1	65	36	1	1	17,17
	82439210320	3,2	3,2	65	36	1	1	17,17
	82439210330	3,3	3,3	65	36	1	1	17,92
	82439210340	3,4	3,4	70	39	1	1	18,53
	82439210350	3,5	3,5	70	39	1	1	18,53
	82439210360	3,6	3,6	70	39	1	1	19,89
	82439210370	3,7	3,7	70	39	1	1	20,81
	82439210380	3,8	3,8	75	43	1	1	20,93
	82439210390	3,9	3,9	75	43	1	1	21,38
	82439210400	4	4	75	43	1	1	19,89
	82439210410	4,1	4,1	75	43	1	1	22,00
	82439210420	4,2	4,2	75	43	1	1	22,00
	82439210430	4,3	4,3	80	47	1	1	29,05
	82439210440	4,4	4,4	80	47	1	1	29,05
	82439210450	4,5	4,5	80	47	1	1	26,50
	82439210460	4,6	4,6	80	47	1	1	29,81
	82439210470	4,7	4,7	80	47	1	1	29,81
	82439210480	4,8	4,8	86	52	1	1	31,15
	82439210490	4,9	4,9	86	52	1	1	31,15
	82439210500	5	5	86	52	1	1	29,05
	82439210510	5,1	5,1	86	52	1	1	33,72
	82439210520	5,2	5,2	86	52	1	1	33,72
	82439210530	5,3	5,3	86	52	1	1	33,72
	82439210540	5,4	5,4	93	57	1	1	38,40

 8243921	Ø	d2	L	I1	QTY	PCB	€
82439210550	5,5	5,5	93	57	1	1	36,13
82439210560	5,6	5,6	93	57	1	1	40,04
82439210570	5,7	5,7	93	57	1	1	40,04
82439210580	5,8	5,8	93	57	1	1	41,55
82439210590	5,9	5,9	93	57	1	1	41,55
82439210600	6	6	93	57	1	1	38,84
82439210610	6,1	6,1	101	63	1	1	52,09
82439210620	6,2	6,2	101	63	1	1	52,09
82439210630	6,3	6,3	101	63	1	1	50,57
82439210640	6,4	6,4	101	63	1	1	51,51
82439210650	6,5	6,5	101	63	1	1	48,03
82439210660	6,6	6,6	101	63	1	1	62,35
82439210670	6,7	6,7	101	63	1	1	62,35
82439210680	6,8	6,8	109	69	1	1	58,57
82439210690	6,9	6,9	109	69	1	1	62,35
82439210700	7	7	109	69	1	1	55,52
82439210750	7,5	7,5	109	69	1	1	60,07
82439210780	7,8	7,8	117	75	1	1	77,98
82439210800	8	8	117	75	1	1	82,21
82439210850	8,5	8,5	117	75	1	1	78,73
82439210900	9	9	125	81	1	1	88,37
82439210950	9,5	9,5	125	81	1	1	99,67
82439211000	10	10	133	87	1	1	115,16
82439211020	10,2	10,2	133	87	1	1	122,54
82439211050	10,5	10,5	133	87	1	1	124,80
82439211100	11	11	142	94	1	1	150,97
82439211150	11,5	11,5	142	94	1	1	167,38
82439211200	12	12	151	101	1	1	179,44
82439211300	13	13	151	101	1	1	216,48
82439211400	14	14	160	108	1	1	251,99

**BROCA CON PUNTA DE METAL DURO sim.DIN 338 | SERIE CORTA |
TALADRADOS DE PROFUNDIDAD MEDIA <3xd | APLICACIÓN:
ACEROS MUY DUROS HASTA 1200 N/mm²**

CARBIDE TIPPED JOBBER LENGTH DRILL | MEDIUM DEEP DRILLING <3xd |
APPLICATION: VERY HARD STEELS UP TO 1200 N/mm²

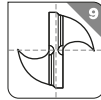
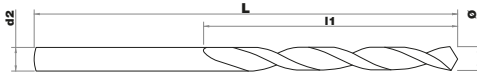

Aceros aleados
200-700 N/mm²
Alloyed steels
200-700N/mm²



Aceros aleados
y tratados
700-1400 N/mm²
Heat treatables steels
700-1400N/mm²

8240201	Ø	d2	L	l1	QTY	PCB	€
82402010200	2	2	49	24	1	1	16,27
82402010210	2,1	2,1	49	24	1	1	18,55
82402010220	2,2	2,2	53	27	1	1	18,55
82402010230	2,3	2,3	53	27	1	1	18,55
82402010240	2,4	2,4	57	30	1	1	18,55
82402010250	2,5	2,5	57	30	1	1	16,27
82402010260	2,6	2,6	57	30	1	1	18,55
82402010270	2,7	2,7	61	33	1	1	18,55
82402010280	2,8	2,8	61	33	1	1	18,55
82402010290	2,9	2,9	61	33	1	1	18,55
82402010300	3	3	61	33	1	1	16,27
82402010310	3,1	3,1	65	36	1	1	18,55
82402010320	3,2	3,2	65	36	1	1	18,55
82402010330	3,3	3,3	65	36	1	1	18,55
82402010340	3,4	3,4	70	39	1	1	18,55
82402010350	3,5	3,5	70	39	1	1	16,27
82402010360	3,6	3,6	70	39	1	1	18,55
82402010370	3,7	3,7	70	39	1	1	18,55
82402010380	3,8	3,8	75	43	1	1	18,55
82402010390	3,9	3,9	75	43	1	1	18,55
82402010400	4	4	75	43	1	1	16,27
82402010410	4,1	4,1	75	43	1	1	19,08
82402010420	4,2	4,2	75	43	1	1	19,08
82402010430	4,3	4,3	80	47	1	1	19,08
82402010440	4,4	4,4	80	47	1	1	19,08
82402010450	4,5	4,5	80	47	1	1	16,69
82402010460	4,6	4,6	80	47	1	1	19,08
82402010470	4,7	4,7	80	47	1	1	19,08
82402010480	4,8	4,8	86	52	1	1	19,08
82402010490	4,9	4,9	86	52	1	1	19,08
82402010500	5	5	86	52	1	1	16,69
82402010510	5,1	5,1	86	52	1	1	19,95
82402010520	5,2	5,2	86	52	1	1	19,95
82402010530	5,3	5,3	86	52	1	1	19,95
82402010540	5,4	5,4	93	57	1	1	19,95
82402010550	5,5	5,5	93	57	1	1	17,58
82402010560	5,6	5,6	93	57	1	1	20,98
82402010570	5,7	5,7	93	57	1	1	20,98
82402010580	5,8	5,8	93	57	1	1	20,98
82402010590	5,9	5,9	93	57	1	1	20,98
82402010600	6	6	93	57	1	1	18,45
82402010610	6,1	6,1	101	63	1	1	24,16
82402010620	6,2	6,2	101	63	1	1	24,16
82402010630	6,3	6,3	101	63	1	1	24,16



8240201	Ø	d2	L	I1	QTY	PCB	€
82402010640	6,4	6,4	101	63	1	1	24,16
82402010650	6,5	6,5	101	63	1	1	21,96
82402010660	6,6	6,6	101	63	1	1	24,16
82402010670	6,7	6,7	101	63	1	1	24,16
82402010680	6,8	6,8	109	69	1	1	24,16
82402010690	6,9	6,9	109	69	1	1	24,16
82402010700	7	7	109	69	1	1	21,96
82402010710	7,1	7,1	109	69	1	1	25,14
82402010720	7,2	7,2	109	69	1	1	25,14
82402010730	7,3	7,3	109	69	1	1	25,14
82402010740	7,4	7,4	109	69	1	1	25,14
82402010750	7,5	7,5	109	69	1	1	22,85
82402010760	7,6	7,6	117	75	1	1	25,14
82402010770	7,7	7,7	117	75	1	1	25,14
82402010780	7,8	7,8	117	75	1	1	25,14
82402010790	7,9	7,9	117	75	1	1	25,14
82402010800	8	8	117	75	1	1	22,85
82402010810	8,1	8,1	117	75	1	1	27,37
82402010820	8,2	8,2	117	75	1	1	27,37
82402010830	8,3	8,3	117	75	1	1	27,37
82402010840	8,4	8,4	117	75	1	1	27,37
82402010850	8,5	8,5	117	75	1	1	24,93
82402010860	8,6	8,6	125	81	1	1	27,37
82402010870	8,7	8,7	125	81	1	1	27,37
82402010880	8,8	8,8	125	81	1	1	27,37
82402010890	8,9	8,9	125	81	1	1	27,37
82402010900	9	9	125	81	1	1	24,93
82402010910	9,1	9,1	125	81	1	1	29,93
82402010920	9,2	9,2	125	81	1	1	29,93
82402010930	9,3	9,3	125	81	1	1	29,93
82402010940	9,4	9,4	125	81	1	1	29,93
82402010950	9,5	9,5	125	81	1	1	27,24
82402010960	9,6	9,6	133	87	1	1	29,93
82402010970	9,7	9,7	133	87	1	1	29,93
82402010980	9,8	9,8	133	87	1	1	29,93
82402010990	9,9	9,9	133	87	1	1	29,93
82402011000	10	10	133	87	1	1	27,24
82402011020	10,2	10,2	133	87	1	1	38,63
82402011050	10,5	10,5	133	87	1	1	35,11
82402011100	11	11	142	94	1	1	35,11
82402011120	11,2	11,2	142	94	1	1	44,43
82402011150	11,5	11,5	142	94	1	1	40,37
82402011200	12	12	151	101	1	1	40,37
82402011220	12,2	12,2	151	101	1	1	53,10
82402011250	12,5	12,5	151	101	1	1	48,27
82402011300	13	13	151	101	1	1	48,27
82402011350	13,5	13,5	160	108	1	1	56,18
82402011400	14	14	160	108	1	1	56,18
82402011420	14,2	14,2	169	114	1	1	70,51
82402011450	14,5	14,5	169	114	1	1	64,07
82402011500	15	15	169	114	1	1	64,07
82402011520	15,2	15,2	178	120	1	1	81,11
82402011550	15,5	15,5	178	120	1	1	73,75
82402011600	16	16	178	120	1	1	73,75
82402011650	16,5	16,5	184	125	1	1	80,77
82402011700	17	17	184	125	1	1	80,77
82402011750	17,5	17,5	191	130	1	1	86,89
82402011800	18	18	191	130	1	1	86,89
82402011850	18,5	18,5	198	135	1	1	107,93
82402011900	19	19	198	135	1	1	107,93
82402011950	19,5	19,5	204	140	1	1	122,88
82402012000	20	20	204	140	1	1	122,88

BROCA METAL DURO MONOBLOC "ROMPECERRADURAS" DISEÑO PARA DESTRUCCIÓN DE CERRADURAS | ALTO RENDIMIENTO
 SOLID CARBIDE DRILL. LOCK DESTROYER | DESIGNED FOR DESTROYING LOCKS | HIGH PERFORMANCE

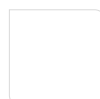
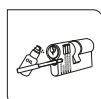
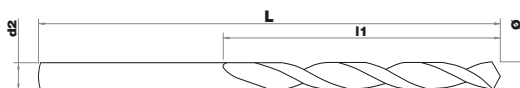

Aceros aleados
200-700 N/mm²
Alloyed steels
200-700N/mm²

8240011	Ø	d2	L	l1	QTY	PCB	€
82400110001	6	6	67	35	1	1	41,38



Aceros aleados
y tratados
700-1400 N/mm²
Heat treatables steels
700-1400N/mm²



Aceros
inoxidables
Stainless
Steels

KIT PARA APERTURA DE CERRADURAS | DISEÑO PARA CERRADURAS DE DESTRUCCIÓN, ALTO RENDIMIENTO.
 SOLID CARBIDE DRILL SET | LOCK DESTROYER | DESIGNED FOR DESTROYING LOCKS, HIGH

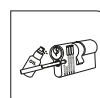
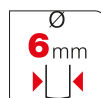

82400170001		
QTY	PCB	€
3	1	62,60

BROCA MULTI-MATERIAL 3 EN 1 | TALADRADO DE METAL, HORMIGÓN Y MADERA
MULTIMAT DRILL BIT 3 IN 1 | METAL, MASONRY AND WOOD DRILLING

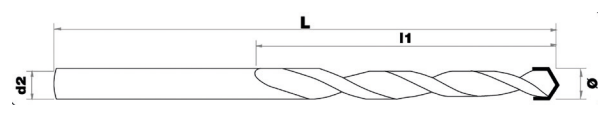

Chapas
Hormigón
Madera blanda
Sheet Steel
Concrete
Softwood

1190184	Ø	L	QTY	PCB	€
11901840300	3	70	1	1	2,93
11901840400	4	75	1	1	2,90
11901840500	5	85	1	1	2,96
11901840600	6	100	1	1	3,12
11901840700	7	100	1	1	4,50
11901840800	8	120	1	1	3,64
11901840900	9	120	1	1	5,20
11901841000	10	120	1	1	6,79
11901841100	11	150	1	1	9,15
11901841200	12	150	1	1	7,61

ESTUCHE BROCAS MULTI-MATERIAL | BROCAS 3 EN 1 Ø 3-4-5-6-8 mm
MULTIMAT SET | DRILLS 3 in 1 Ø 3-4-5-6-8 mm



11901870001		
QTY	PCB	€
5	1	18,18



DAJ57-51-1
MT3-19-50



■ **FRESAS PARA
TALADRO MAGNÉTICO 80**
CORE HOLE DRILLS

FRESA HUECA HSS TIALN WELDON | SERIE CORTA | APLICACIÓN: ACEROS HASTA 950 N/mm², INOXIDABLES Y FUNDICIÓN

HSS TIALN CORE HOLE DRILL WELDON | SHORT SERIE | APPLICATION:
 STEELS UP TO 950 N/mm², STAINLESS STEELS AND CAST IRON

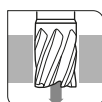
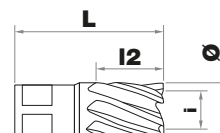

Aceros aleados y tratados < 950N/mm²
 Heat Treatable Steels < 950N/mm²



Aceros inoxidables
 Stainless Steels



Fundiciones
 Cast iron

1037001	Ø	L	I2	i	Z	QTY	PCB	€
10370011200	12	60	30	6	4	1	1	42,85
10370011300	13	60	30	6	4	1	1	43,49
10370011400	14	60	30	6	4	1	1	44,00
10370011500	15	60	30	6	4	1	1	44,19
10370011600	16	60	30	7	5	1	1	44,27
10370011700	17	60	30	8	5	1	1	47,43
10370011800	18	60	30	9	5	1	1	47,78
10370011900	19	60	30	10	5	1	1	46,90
10370012000	20	60	30	11	5	1	1	50,59
10370012100	21	60	30	12	5	1	1	52,08
10370012200	22	60	30	13	6	1	1	54,24
10370012300	23	60	30	14	6	1	1	56,16
10370012400	24	60	30	15	6	1	1	58,07
10370012500	25	60	30	16	6	1	1	59,98
10370012600	26	60	30	17	6	1	1	61,69
10370012700	27	60	30	18	6	1	1	66,30
10370012800	28	60	30	19	8	1	1	68,97
10370012900	29	60	30	20	8	1	1	71,42
10370013000	30	60	30	21	8	1	1	73,22
10370013100	31	60	30	22	8	1	1	79,76
10370013200	32	60	30	23	8	1	1	79,31
10370013300	33	60	30	24	8	1	1	87,19
10370013400	34	60	30	25	10	1	1	89,37
10370013500	35	60	30	26	10	1	1	98,33
10370013600	36	60	30	27	10	1	1	100,77
10370013700	37	60	30	28	10	1	1	106,48
10370013800	38	60	30	29	10	1	1	107,86
10370013900	39	60	30	30	10	1	1	111,88
10370014000	40	60	30	31	12	1	1	114,63
10370014100	41	60	30	32	12	1	1	119,18
10370014200	42	60	30	33	12	1	1	125,54
10370014300	43	60	30	34	12	1	1	128,20
10370014400	44	60	30	35	12	1	1	137,23
10370014500	45	60	30	36	12	1	1	141,62
10370014600	46	60	30	37	14	1	1	144,51
10370014700	47	60	30	38	14	1	1	149,24
10370014800	48	60	30	39	14	1	1	156,22
10370014900	49	60	30	40	14	1	1	158,51
10370015000	50	60	30	41	14	1	1	162,45

FRESAS HUECAS
CORE HOLE DRILLING



FRESA HUECA HSS TIALN WELDON | SERIE LARGA | APLICACIÓN: ACEROS HASTA 950 N/mm², INOXIDABLES Y FUNDICIÓN

HSS TIALN CORE HOLE DRILL WELDON | LONG SERIE | APPLICATION: STEELS
UP TO 950 N/mm², STAINLESS STEELS AND CAST IRON

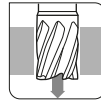
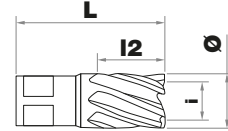

Aceros aleados
y tratados
< 950N/mm²
Heat Treatable
Steels
<950N/mm²



Aceros
inoxidables
Stainless
Steels



Fundiciones
Cast iron

1037011	Ø	L	I2	i	Z	QTY	PCB	€
10370111200	12	80	50	6	4	1	1	63,41
10370111300	13	80	50	6	4	1	1	63,70
10370111400	14	80	50	6	4	1	1	64,04
10370111500	15	80	50	6	4	1	1	64,41
10370111600	16	80	50	7	5	1	1	64,99
10370111700	17	80	50	8	5	1	1	65,41
10370111800	18	80	50	9	5	1	1	65,69
10370111900	19	80	50	10	5	1	1	66,42
10370112000	20	80	50	11	5	1	1	69,46
10370112100	21	80	50	12	5	1	1	71,21
10370112200	22	80	50	14	6	1	1	73,50
10370112300	23	80	50	14	6	1	1	78,29
10370112400	24	80	50	15	6	1	1	80,63
10370112500	25	80	50	16	6	1	1	81,03
10370112600	26	80	50	17	6	1	1	84,75
10370112700	27	80	50	18	6	1	1	90,48
10370112800	28	80	50	19	8	1	1	94,36
10370112900	29	80	50	20	8	1	1	98,25
10370113000	30	80	50	21	8	1	1	102,39
10370113100	31	80	50	22	8	1	1	107,31
10370113200	32	80	50	23	8	1	1	112,15
10370113300	33	80	50	24	8	1	1	117,50
10370113400	34	80	50	25	10	1	1	121,90
10370113500	35	80	50	26	10	1	1	126,94
10370113600	36	80	50	27	10	1	1	132,59
10370113700	37	80	50	28	10	1	1	134,77
10370113800	38	80	50	29	10	1	1	139,68
10370113900	39	80	50	30	10	1	1	149,59
10370114000	40	80	50	31	12	1	1	153,70
10370114100	41	80	50	32	12	1	1	155,31
10370114200	42	80	50	33	12	1	1	170,73
10370114300	43	80	50	34	12	1	1	175,85
10370114400	44	80	50	35	12	1	1	180,59
10370114500	45	80	50	36	12	1	1	182,42
10370114600	46	80	50	37	14	1	1	195,57
10370114700	47	80	50	38	14	1	1	198,83
10370114800	48	80	50	39	14	1	1	205,11
10370114900	49	80	50	40	14	1	1	207,13
10370115000	50	80	50	41	14	1	1	208,21

FRESA HUECA HSS WELDON | SERIE CORTA |
APLICACIÓN: ACEROS BLANDOS HASTA 400 N/mm²

HSS CORE HOLE DRILL WELDON | SHORT SERIE |
 APPLICATION: SOFT STEELS UP TO 400 N/mm²

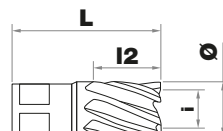

HSS

BRIGHT UNCOATED

TIVOLY NORM

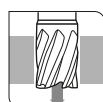

Z 4-14

WELDON 19mm

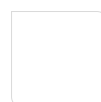
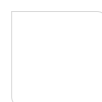

A

Aceros débilmente aleados <400 N/mm²
 Low alloyed steels <400N/mm²

1037051	Ø	L	I2	i	Z	QTY	PCB	€
10370511200	12	60	30	6	4	1	1	24,59
10370511300	13	60	30	6	4	1	1	24,95
10370511400	14	60	30	6	4	1	1	25,25
10370511500	15	60	30	7	4	1	1	25,34
10370511600	16	60	30	8	5	1	1	25,38
10370511700	17	60	30	9	5	1	1	27,24
10370511800	18	60	30	10	5	1	1	27,41
10370511900	19	60	30	11	5	1	1	26,92
10370512000	20	60	30	12	6	1	1	29,04
10370512100	21	60	30	13	6	1	1	29,90
10370512200	22	60	30	14	6	1	1	31,12
10370512300	23	60	30	15	6	1	1	32,25
10370512400	24	60	30	16	6	1	1	33,35
10370512500	25	60	30	17	6	1	1	34,44
10370512600	26	60	30	18	6	1	1	35,38
10370512700	27	60	30	19	6	1	1	38,06
10370512800	28	60	30	20	8	1	1	39,56
10370513000	30	60	30	22	8	1	1	42,01
10370513200	32	60	30	24	8	1	1	45,50
10370513400	34	60	30	24	14	1	1	52,38
10370513500	35	60	30	27	10	1	1	56,41
10370513600	36	60	30	24	14	1	1	58,84
10370513800	38	60	30	30	10	1	1	61,90
10370514000	40	60	30	32	10	1	1	65,76
10370514200	42	60	30	34	10	1	1	72,03
10370514500	45	60	30	37	12	1	1	81,26
10370514800	48	60	30	40	12	1	1	89,65
10370515000	50	60	30	42	12	1	1	93,22

FRESAS HUECAS
CORE HOLE DRILLING



FRESA HUECA HSS WELDON | SERIE LARGA |

APLICACIÓN: ACEROS BLANDOS HASTA 400 N/mm²

HSS CORE HOLE DRILL WELDON | LONG SERIE |

APPLICATION: SOFT STEELS UP TO 400 N/mm²

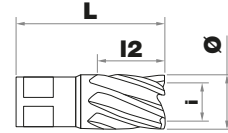

HSS

BRIGHT UNCOATED

TIVOLY NORM

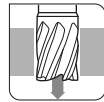

**Z
4-14**

**WELDON
19mm**



A

Aceros débilmente aleados <400 N/mm²
Low alloyed steels <400N/mm²

1037061	Ø	L	I2	i	Z	QTY	PCB	€
10370611200	12	80	50	6	4	1	1	36,39
10370611300	13	80	50	6	4	1	1	36,53
10370611400	14	80	50	6	4	1	1	36,76
10370611500	15	80	50	7	4	1	1	36,94
10370611600	16	80	50	8	5	1	1	37,30
10370611700	17	80	50	9	5	1	1	37,54
10370611800	18	80	50	10	5	1	1	37,69
10370611900	19	80	50	11	5	1	1	38,13
10370612000	20	80	50	12	6	1	1	39,87
10370612100	21	80	50	13	6	1	1	40,87
10370612200	22	80	50	14	6	1	1	42,20
10370612300	23	80	50	15	6	1	1	44,92
10370612400	24	80	50	16	6	1	1	46,26
10370612500	25	80	50	17	6	1	1	46,51
10370612600	26	80	50	18	6	1	1	48,63
10370612700	27	80	50	19	6	1	1	51,92
10370612800	28	80	50	20	8	1	1	54,16
10370613000	30	80	50	22	8	1	1	58,75
10370613200	32	80	50	24	8	1	1	64,36
10370613500	35	80	50	27	10	1	1	72,85
10370613800	38	80	50	30	10	1	1	80,16
10370614000	40	80	50	32	12	1	1	88,22
10370614200	42	80	50	34	12	1	1	98,00
10370614500	45	80	50	37	12	1	1	104,68
10370614800	48	80	50	40	14	1	1	117,71
10370615000	50	80	50	42	14	1	1	119,45



ESTUCHE DE 4 FRESAS HUECAS HSS TiALN | Ø 12-14-18- 22 + EXPULSOR

SET OF 4 CORE HOLE DRILLS HSS TiALN | Ø 12-14-18- 22 + EJECTOR



FCH 04

WELDON 19mm

04 PCS

HSS

TiALN COATED

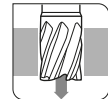

10370070001

QTY	PCB	€
4	1	197,90



ESTUCHE DE 8 FRESAS HUECAS HSS TiALN | Ø 12-14-14-16-18-18-22 + EXPULSOR

SET OF 8 CORE HOLE DRILLS HSS TiALN | Ø 12-14-14-16-18-18-22 + EJECTOR



FCH 08

WELDON 19mm

08 PCS

HSS

TiALN COATED

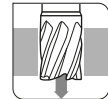

10370070005

QTY	PCB	€
8	1	327,09



FRESA PARA DESBASTAR HSS WELDON | PARA ACEROS HASTA 400 N/mm²

HSS DEBURRING TOOLS WELDON | SOFT STEELS UP TO 400 N/mm²

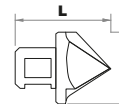

HSS

BRIGHT UNCOATED

TIVOLY NORM



Z3

WELDON 19mm



Aceros débilmente aleados <400 N/mm²
Low alloyed steels <400N/mm²

1037031	Ø	L	Z	QTY	PCB	€
10370312500	25	43	3	1	1	130,54
10370313000	30	47	3	1	1	145,14
10370314000	40	52	3	1	1	172,39
10370315500	55	63	4	1	1	258,03



EXPULSORES PARA FRESA HUECA | PUNTEADO PREVIO AL TALADRADO Y EXTRACTOR

PILOT PIN FOR CORE HOLE DRILL | POINTING BEFORE DRILLING AND CORE EJECTION



TIVOLY
NORM

WELDON
19mm

111121	Ø	L	QTY	PCB	€
1111210001	6.34	77	1	1	12,40
1111210002	6.34	103	1	1	13,58

FRESAS HUECAS
CORE HOLE DRILLING



ADAPTADOR FEIN A WELDON | PARA USO CON FRESAS HUECAS WELDON EN MÁQUINAS FEIN

ADAPTER FEIN => WELDON | FOR USE WITH WELDON CORE HOLE DRILL ON FEIN MACHINE

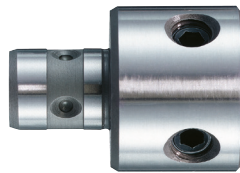

TIVOLY
NORM

WELDON
19mm

FEIN
QUICK-IN

111151	Ø	L	QTY	PCB	€
1111510001	6.34	77	1	1	34,03

ADAPTADORES DE CM A WELDON | PARA USO CON FRESAS HUECAS WELDON EN TALADROS DE COLUMNA

ARBOR HOLDERS CM => WELDON | FOR USE WITH WELDON CORE HOLE DRILL ON CM COLUMN DRILL

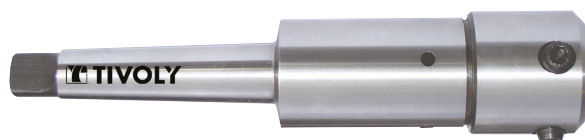

**TIVOLY
NORM**

**WELDON
19mm**

1111131	Ø	CM	QTY	PCB	€
11111310002	19	2	1	1	154,56
11111310003	19	3	1	1	166,53

ADAPTADORES DE CM A WELDON CON SISTEMA DE LUBRICACIÓN INTEGRADO | PARA USO CON FRESAS HUECAS WELDON EN TALADROS DE COLUMNA

ARBOR HOLDERS WITH LUBRICATION | CM => WELDON | FOR USE WITH WELDON CORE HOLE DRILL ON CM COLUMN DRILL

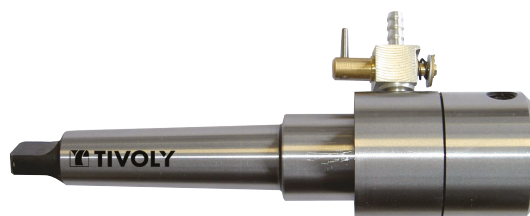

**TIVOLY
NORM**

**WELDON
19mm**





1111141	Ø	CM	QTY	PCB	€
11111410002	19	2	1	1	359,10
11111410003	19	3	1	1	366,14









■ TABLA APLICACIONES MACHOS	90
APPLICATIONS TABLE TAPS	
■ MACHOS DE ROSCAR	94
REGULAR TAPS	
■ MACHOS DE ROSCAR MULTI-APLICACIÓN	126
GENERAL PURPOSE TAPS	
■ MACHOS DE ROSCAR FLASH-CUT	145
FLASH-CUT TAPS	
■ COJINETES	167
DIES	
■ ACCESORIOS	174
ACCESSORIES	
■ ESTUCHES	177
SETS	



		ESTÁNDAR									
		201 301	301	252 352	222	002	302	310	301	255 355	
				6G SOBRE MEDIDA		LH IZDA.		CONIC. 1:16		CONIC. 1:16	
M-MF UNC-UNF BSP GAS BSW NPT	PAG. INDEX	106		108	109	109					110
				116							118
			122				122				
				120							121
								124	124		
Material		HSS-E	HSS-E	HSS-E	HSS-E	HSS-E	HSS-E	HSS	HSS	HSS-E	
Recubrimiento/Coating		BRILLANTE BRIGHT									
Tipo de orificio /Type of hole											
A	A1	Aceros debilmente aleados / Unalloyed & low alloyed steels									
B	B1	Aceros de construcción / Structural steels									
B	B2	Aceros bonificados / Plain carbon steels									
B	B3	Aceros aleados / Alloyed steels									
C	C1	Aceros para tratamiento térmico / Heat Treatable Steels R < 1000 N/mm ²									
D	D1	Aceros para tratamiento térmico / Heat Treatable Steels R > 1200 N/mm ²									
F	F1	Aceros inoxidables ferríticos / Stainless Steels, Ferritic									
G	G1	Aceros inoxidables martensíticos / Stainless Steels, Martensitic									
H	H1	Aceros inoxidables austeníticos / Austenitic stainless steel R < 850 N/mm ²									
H	H2	Aleaciones de Ni-Cr / Chromium and nickel alloys R < 1200 N/mm ²									
I	I1	Fundición gris con grafito laminar / Cast Iron with lamellar graphite									
J	J1	Fundición con grafito laminar / Lamellar graphite cast iron (GG) 500 < R ≤ 1000 N/mm ²									
	J2	Fundición maleable / Malleable cast iron (GGG) R ≤ 750 N/mm ²									
	J3	Fundición grafito esferoidal/Spheroidal graphite cast iron (GGG) 750 < R ≤ 1000 N/mm ²									
K	K1	Aluminio y magnesio no aleado / Not alloyed aluminum and magnesium									
	K2	Aleaciones de magnesio / Magnesium alloys									
L	L1	Aleaciones de Aluminio / Aluminum alloys Si < 0,5% R < 500 N/mm ²									
	L2	Aleaciones de Aluminio / Aluminum alloys with 0,5% < Si < 10% R < 600 N/mm ²									
M	M1	Aleaciones de Aluminio / Aluminium alloys Si > 10% R < 600 N/mm ²									
N	N1	Cobre R ≤ 350 N / mm ² / Copper R ≤ 350 N/mm ²									
	N2	Aleaciones de cobre viruta corta / Short chip copper alloys									
	N3	Aleaciones de cobre viruta larga / Long chip copper alloys									
Q	Q1	Niquel / Nickel R ≤ 500 N/mm ²									
	Q1	Aleaciones de niquel / Nickel alloys R < 900 N/mm ² (INCONEL 600)									
P	P1	Plásticos / Thermoplastique / Thermoplastic									

Este cuadro es una recomendación inicial que hay que confirmar con la aplicación real | This chart is an initial recommendation, you must check with the real application

ESTÁNDAR				MULTI-APLICACIÓN				FLASH CUT													
225	005	305	303	202 302	342	205 305	345	CT1	BT1	ST2	IT2	AT2	ST5	IT5	AT5	SRH	IRH	GSH			
6G SOBRE MEDIDA	LH IZDA.		15°										DIENTE ALTERNO		DIENTE ALTERNO	ROLL. RAN.	ROLL. RAN.	ROLL. RAN.			
111	111			132		136		164	161	146	151	156	147	155	157	148	153	158			
		123	123		132		129	165	162	149	154	159	150	155	160						
								166	163												
HSS-E	HSS-E	HSS-E	HSS-E	HSS-E	HSS-E	HSS-E	HSS-E	HSS-E	HSS-E	HSS-E	HSS-EE	HSS-EE	HSS-E	HSS-EE	HSS-EE	HSS-EE	HSS-EE	HSS-EE			
BRILLANTE BRIGHT				VAPORIZADO STEAM				TiCN		TiN	TiCN	TiN	TiN	TiCN MP	TiN	TiN	TiCN MP	TiN			
																					
A1	●	●	●	●	●	●	●									●		○			
B1	○	○	○	○	○	○	○			●	●			●	●	●		○			
B2	○	○	○	○	○	○	○			●	●			●	●			○			
B3	○	○	○	○	○	○	○			●	●			●	●			○			
C1										○				○			○				
D1																					
F1				○	○	○	○				●			●			●				
G1				○	○	○	○				●			●			●				
H1				○	○	○	○				●			●			○				
H2																	○				
I1								●													
J1				○	○	○	○	●		○				○							
J2				○	○	○	○	●		○				○							
J3				○	○	○	○	●		○											
K1												●			●	○		●			
K2												●			●	○		●			
L1												●			●	○		●			
L2												●			●	○		●			
M1												●			●			●			
N1									●							○		●			
N2																○		●			
N3																○		●			
Q1																○		●			
Q1																○		●			
P1																					

● Recomendado / Suggested

○ Alternativo / alternative



- **MACHOS DE MANO M-MF** **94**
REGULAR-HAND TAPS
M-MF
- **MACHOS DE MANO UNC-UNF** **100**
REGULAR-HAND TAPS
UNC-UNF
- **MACHOS DE MANO BSW-BSF** **102**
REGULAR-HAND TAPS
BSW-BSF
- **MACHOS DE MANO BSP GAS** **104**
REGULAR-HAND TAPS
BSP GAS

Ref.
151



JUEGO DE 3 MACHOS DE MANO HSS DIN 352 | MÉTRICO | AGUJERO PASANTE/CIEGO | APLICACIÓN: ACEROS BLANDOS HASTA 400 N/mm²

SET OF 3 HSS DIN 352 HAND TAPS | METRIC | THROUGH/BLIND HOLE |

APPLICACIÓN: SOFT STEELS UP TO 400 N/mm²

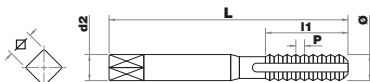

HSS

BRIGHT UNCOATED

DIN 352

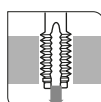

x3 SET

6H

M

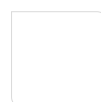

A

Aceros débilmente aleados <400 N/mm²
Low alloyed steels <400N/mm²

1501511	Ø	P	L	l	d2	DIN	QTY	PCB	€
150151100100025	M1	0,25	32	5,5	2,5	352	1	1	56,88
150151100120025	M1,2	0,25	32	5,5	2,5	352	1	1	56,88
150151100140030	M1,4	0,3	32	7	2,5	352	1	1	56,88
150151100200040	M2	0,4	36	9	2,8	352	1	1	26,24
150151100220045	M2,2	0,45	36	9	2,8	352	1	1	27,74
150151100230040	M2,3	0,4	36	9	2,8	352	1	1	27,74
150151100250045	M2,5	0,45	40	10	2,8	352	1	1	25,56
150151100260045	M2,6	0,45	40	9	2,8	352	1	1	24,89
150151100300050	M3	0,5	40	11	3,5	352	1	1	15,65
150151100350060	M3,5	0,6	45	13	4	352	1	1	18,79
150151100400070	M4	0,7	45	13	4,5	352	1	1	15,65
150151100450075	M4,5	0,75	50	16	6	352	1	1	24,43
150151100500080	M5	0,8	50	15	6	352	1	1	16,29
150151100600100	M6	1	50	16	6	352	1	1	16,29
150151100700100	M7	1	50	19	6	352	1	1	20,19
150151100800125	M8	1,25	56	22	6	352	1	1	18,90
150151100900125	M9	1,25	63	22	6	352	1	1	32,35
150151101000150	M10	1,5	70	24	7	352	1	1	24,34
150151101100150	M11	1,5	70	24	8	352	1	1	40,78
150151101200175	M12	1,75	75	29	9	352	1	1	34,84
150151101400200	M14	2	80	30	11	352	1	1	41,15
150151101500200	M15	2	80	32	12	352	1	1	68,42
150151101600200	M16	2	80	32	12	352	1	1	56,35
150151101800250	M18	2,5	95	40	14	352	1	1	77,00
150151102000250	M20	2,5	95	40	16	352	1	1	85,47
150151102200250	M22	2,5	100	40	18	352	1	1	112,70
150151102400300	M24	3	110	45	18	352	1	1	132,24
150151102700300	M27	3	110	50	20	352	1	1	168,43
150151103000350	M30	3,5	125	56	22	352	1	1	215,29
150151103300350	M33	3,5	125	56	25	352	1	1	273,49
150151103600400	M36	4	150	63	28	352	1	1	349,26
150151103900400	M39	4	150	63	32	352	1	1	389,26
150151104200450	M42	4,5	150	63	32	352	1	1	489,44
150151104500450	M45	4,5	160	70	36	352	1	1	543,05
150151105200500	M52	5	180	75	40	352	1	1	765,51
150151105600550	M56	5,5	200	85	45	352	1	1	1.095,71
150151106000550	M60	5,5	200	85	45	352	1	1	1.108,16
150151106400600	M64	6	220	90	50	352	1	1	1.347,33
150151106800600	M68	6	220	90	50	352	1	1	1.613,00

● Ampliación de gama | Extended range

Ref.
152



**JUEGO DE 2 MACHOS DE MANO HSS DIN 2181 | MÉTRICO FINO |
AGUJERO PASANTE/CIEGO | APLICACIÓN: ACEROS BLANDOS HASTA
400 N/mm²**

SET OF 2 HSS DIN 2181 HAND TAPS | METRIC FINE | THROUGH/BLIND HOLE |
APPLICATION: SOFT STEELS UP TO 400 N/mm²

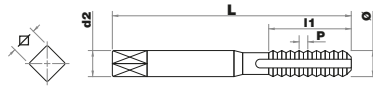

HSS

**BRIGHT
UNCOATED**

**DIN
2181**

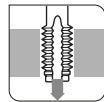

**x2
SET**

6H

MF



A

Aceros débilmente
aleados <400 N/mm²
Low alloyed
steels <400N/mm²

1501521	Ø	P	L	I	d2	DIN	QTY	PCB	€
150152100400050	MF4	0,5	50	14,5	6	2181	1	1	26,69
150152100450050	MF4,5	0,5	50	12	6	2181	1	1	26,68
150152100500050	MF5	0,5	50	11	6	2181	1	1	28,50
150152100500075	MF5	0,75	50	11	6	2181	1	1	27,18
150152100600050	MF6	0,5	50	14	6	2181	1	1	22,28
150152100600075	MF6	0,75	50	14	6	2181	1	1	17,21
150152100700050	MF7	0,5	50	14	6	2181	1	1	24,96
150152100700075	MF7	0,75	50	19	6	2181	1	1	20,28
150152100800050	MF8	0,5	50	19	6	2181	1	1	33,64
150152100800075	MF8	0,75	50	18	6	2181	1	1	23,25
150152100800100	MF8	1	56	22	6	2181	1	1	17,20
150152100900100	MF9	1	63	20	7	2181	1	1	23,46
150152101000050	MF10	0,5	63	20	7	2181	1	1	35,65
150152101000100	MF10	1	63	18	7	2181	1	1	18,43
150152101000125	MF10	1,25	70	24	7	2181	1	1	18,66
150152101100100	MF11	1	63	20	8	2181	1	1	32,43
150152101200050	MF12	0,5	70	22	9	2181	1	1	36,19
150152101200075	MF12	0,75	70	22	9	2181	1	1	48,67
150152101200100	MF12	1	70	20	9	2181	1	1	32,18
150152101200125	MF12	1,25	70	20	9	2181	1	1	32,23
150152101200150	MF12	1,5	70	20	9	2181	1	1	80,06
150152101300100	MF13	1	70	22	11	2181	1	1	51,52
150152101300150	MF13	1,5	70	22	11	2181	1	1	48,34
150152101400075	MF14	0,75	70	20	9	2181	1	1	61,51
150152101400100	MF14	1	70	22	11	2181	1	1	48,20
150152101400125	MF14	1,25	70	22	11	2181	1	1	42,43
150152101400150	MF14	1,5	70	22	11	2181	1	1	32,98
150152101500100	MF15	1	70	22	12	2181	1	1	68,26
150152101500150	MF15	1,5	70	22	12	2181	1	1	63,32
150152101600100	MF16	1	70	22	12	2181	1	1	67,52
150152101600125	MF16	1,25	70	22	12	2181	1	1	68,03
150152101600150	MF16	1,5	70	22	12	2181	1	1	41,25
150152101800100	MF17	1,5	70	22	12	2181	1	1	104,39
150152101800100	MF18	1	80	22	14	2181	1	1	75,01
150152101800125	MF18	1,25	80	22	14	2181	1	1	99,83
150152101800150	MF18	1,5	80	22	14	2181	1	1	54,56
150152101800200	MF18	2	80	22	14	2181	1	1	80,06
150152101900150	MF19	1,5	80	22	14	2181	1	1	151,49
150152102000100	MF20	1	80	22	16	2181	1	1	99,42

● Ampliación de gama | Extended range

1501521	Ø	P	L	I	d2	DIN	QTY	PCB	€
150152102000125	MF20	1,25	80	22	16	2181	1	1	150,94
150152102000150	MF20	1,5	80	22	16	2181	1	1	68,34
150152102000200	MF20	2	80	22	16	2181	1	1	83,38
150152102100150	MF21	1,5	80	22	16	2181	1	1	151,09
150152102200100	MF22	1	80	22	18	2181	1	1	106,70
150152102200125	MF22	1,25	80	22	18	2181	1	1	149,49
150152102200150	MF22	1,5	80	22	18	2181	1	1	74,52
150152102200200	MF22	2	80	22	18	2181	1	1	111,41
150152102400150	MF24	1,5	90	22	18	2181	1	1	95,07
150152102400200	MF24	2	90	22	18	2181	1	1	124,61
150152102500100	MF25	1	90	22	18	2181	1	1	166,88
150152102500150	MF25	1,5	90	22	18	2181	1	1	153,23
150152102600150	MF26	1,5	90	22	18	2181	1	1	139,97
150152102700100	MF27	1	90	22	20	2181	1	1	164,24
150152102700150	MF27	1,5	90	22	20	2181	1	1	156,46
150152102700200	MF27	2	90	22	18	2181	1	1	172,70
150152102800150	MF28	1,5	90	22	20	2181	1	1	155,49
150152102800200	MF28	2	90	22	20	2181	1	1	186,03
150152103000100	MF30	1	90	22	22	2181	1	1	172,67
150152103000150	MF30	1,5	90	22	22	2181	1	1	162,44
150152103000200	MF30	2	90	22	22	2181	1	1	187,26
150152103000300	MF30	3	125	56	18	2181	1	1	186,75
150152103200150	MF32	1,5	90	22	22	2181	1	1	192,01
150152103300150	MF33	1,5	100	25	25	2181	1	1	205,36
150152103300200	MF33	2	100	25	25	2181	1	1	259,28
150152103400150	MF34	1,5	100	25	28	2181	1	1	235,29
150152103500150	MF35	1,5	100	25	28	2181	1	1	258,12
150152103600150	MF36	1,5	100	25	28	2181	1	1	252,01
150152103600200	MF36	2	125	40	28	2181	1	1	323,04
150152103600300	MF36	3	125	40	28	2181	1	1	426,65
150152103800150	MF38	1,5	100	25	28	2181	1	1	283,47
150152103900150	MF39	1,5	110	25	32	2181	1	1	375,19
150152103900200	MF39	2	125	40	32	2181	1	1	375,19
150152103900300	MF39	3	125	40	32	2181	1	1	361,91
150152104000150	MF40	1,5	110	25	32	2181	1	1	332,88
150152104000200	MF40	2	125	40	32	2181	1	1	373,24
150152104200150	MF42	1,5	110	25	32	2181	1	1	368,42
150152104200200	MF42	2	125	40	32	2181	1	1	428,94
150152104200300	MF42	3	125	40	32	2181	1	1	430,79
150152104500150	MF45	1,5	110	25	36	2181	1	1	402,42
150152104500200	MF45	2	125	40	36	2181	1	1	515,13
150152104500300	MF45	3	125	40	36	2181	1	1	515,13
150152104800150	MF48	1,5	140	40	36	2181	1	1	449,28
150152104800200	MF48	2	140	40	36	2181	1	1	624,24
150152104800300	MF48	3	140	40	36	2181	1	1	624,24
150152105000150	MF50	1,5	140	40	36	2181	1	1	491,34
150152105200150	MF52	1,5	140	40	40	2181	1	1	520,12
150152105200200	MF52	2	140	40	40	2181	1	1	754,65
150152105200300	MF52	3	140	40	40	2181	1	1	694,79

● Ampliación de gama | Extended range

Ref.
005



**JUEGO DE 3 MACHOS DE MANO HSS DIN 352 | MÉTRICO |
AGUJERO PASANTE/CIEGO | APLICACIÓN: ACEROS BLANDOS HASTA
400 N/mm²**

SET OF 3 HSS DIN 352 HAND TAPS | METRIC | THROUGH/BLIND HOLE |
APPLICATION: SOFT STEELS UP TO 400 N/mm²

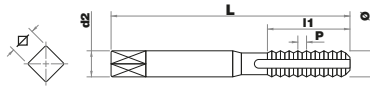

HSS

**BRIGHT
UNCOATED**

**DIN
352**

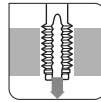

**X3
SET**

6H

M



A

Aceros débilmente
aleados <400 N/mm²
Low alloyed
steels <400N/mm²

1050051	Ø	P	L	l	d2	DIN	QTY	PCB	€
1050051030050	M3	0,5	40	11	3,5	352	1	1	12,23
1050051040070	M4	0,7	45	13	4	352	1	1	12,23
1050051050080	M5	0,8	50	15	6	352	1	1	12,23
1050051060100	M6	1	50	16	6	352	1	1	12,75
1050051070100	M7	1	50	19	6	352	1	1	13,70
1050051080125	M8	1,25	56	22	6	352	1	1	14,69
1050051100150	M10	1,5	70	24	7	352	1	1	17,58
1050051120175	M12	1,75	75	29	9	352	1	1	21,38
1050051140200	M14	2	80	30	11	352	1	1	29,96
1050051160200	M16	2	80	32	12	352	1	1	37,97
1050051180250	M18	2,5	95	40	14	352	1	1	43,96
1050051200250	M20	2,5	95	40	16	352	1	1	56,25
1050051220250	M22	2,5	100	40	18	352	1	1	66,19
1050051240300	M24	3	110	45	18	352	1	1	81,57
1050051270300	M27	3	110	50	20	352	1	1	100,00
1050051300350	M30	3,5	125	56	22	352	1	1	130,81

MACHOS & COJINETES
CORE HOLE DRILLING

Ref.
108



**JUEGO DE 3 MACHOS DE MANO HSS DIN 352 |
ROSCADO A IZQUIERDA | MÉTRICO | AGUJERO PASANTE/CIEGO |
APLICACIÓN: ACEROS BLANDOS HASTA 400 N/mm²**

SET OF 3 HSS DIN 352 HAND TAPS | **LEFT HAND** | METRIC |
APPLICATION: THROUGH/BLIND HOLE SOFT STEELS UP TO 400 N/mm²

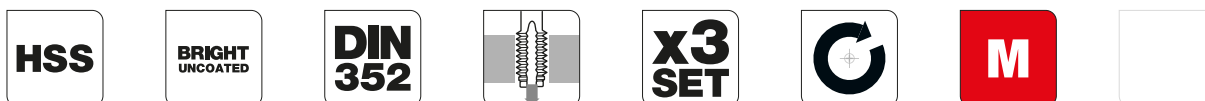
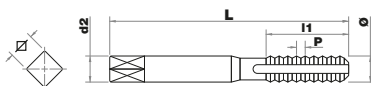

Aceros débilmente
aleados <400 N/mm²
Low alloyed
steels <400N/mm²

9501081	Ø	P	L	l	d2	DIN	QTY	PCB	€
950108100300050	M3	0,5	40	11	3,5	352	1	1	27,43
950108100400070	M4	0,7	45	13	4,5	352	1	1	49,40
950108100500080	M5	0,8	50	15	6	352	1	1	51,35
950108100600100	M6	1	50	16	6	352	1	1	51,35
950108100800125	M8	1,25	56	22	6	352	1	1	59,64
950108101000150	M10	1,5	70	24	7	352	1	1	76,76
950108101200175	M12	1,75	75	29	9	352	1	1	109,88
950108101400200	M14	2	80	30	11	352	1	1	119,31
950108101600200	M16	2	80	32	12	352	1	1	163,43
950108101800250	M18	2,5	95	40	14	352	1	1	128,18
950108102000250	M20	2,5	95	40	16	352	1	1	143,80
950108102200250	M22	2,5	100	40	18	352	1	1	193,11
950108102400300	M24	3	110	50	18	352	1	1	247,42
950108102700300	M27	3	110	50	20	352	1	1	291,26
950108103000350	M30	3,5	125	56	22	352	1	1	374,85

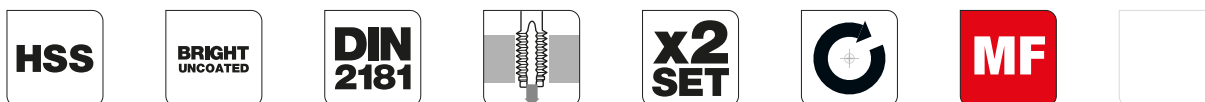

Aceros débilmente
aleados <400 N/mm²
Low alloyed
steels <400N/mm²

9501061	Ø	P	L	l	d2	DIN	QTY	PCB	€
950106100800100	MF8	1	56	22	6	352	1	1	32,92
950106101000100	MF10	1	63	20	7	352	1	1	35,26
950106101000125	MF10	1,25	70	24	7	352	1	1	35,75
950106101200100	MF12	1	70	22	9	352	1	1	62,52
950106101200125	MF12	1,25	70	22	9	352	1	1	62,33
950106101200150	MF12	1,5	70	22	9	352	1	1	53,12
950106101400150	MF14	1,5	70	22	11	352	1	1	59,19
950106101600150	MF16	1,5	70	22	12	352	1	1	73,64
950106101800150	MF18	1,5	80	22	14	352	1	1	97,04
950106102000150	MF20	1,5	80	22	16	352	1	1	121,52

● Ampliación de gama | Extended range

Ref.
103



JUEGO 3 DE MACHOS DE MANO ACERO SINTERIZADO PULVIMETALÚRGICO (HSSEE) ISO 529 | N°1 CON GUÍA | MÉTRICO | AGUJERO PASANTE/CIEGO | APLICACIÓN: ACEROS MUY DUROS HASTA 1400 N/mm², ACEROS INOXIDABLES

SET OF 3 HSSEE [ASP] ISO 529 HAND TAPS | SERIAL TYPE WITH PILOT | METRIC | THROUGH/BLIND HOLE | APPLICATION: VERY HARD STEELS UP TO 1400 N/mm², STAINLESS STEELS

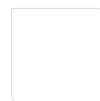
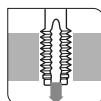
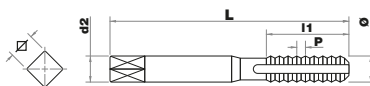

Aceros aleados
200-700 N/mm²
Alloyed steels
200-700N/mm²



Aceros aleados
y tratados
700-1400 N/mm²
Heat treatables steels
700-1400N/mm²



Aceros
inoxidables
Stainless
Steel

9501031	Ø	P	L	I	d2	ISO	QTY	PCB	€
950103100300050	M3	0,5	48	11	3,15	529	1	1	34,87
950103100400070	M4	0,7	53	13	4	529	1	1	34,87
950103100500080	M5	0,8	58	16	5	529	1	1	36,38
950103100600100	M6	1	66	19	6,3	529	1	1	39,19
950103100800125	M8	1,25	72	22	8	529	1	1	44,46
950103101000150	M10	1,5	80	24	10	529	1	1	53,48
950103101200175	M12	1,75	89	29	9	529	1	1	77,55
950103101400200	M14	2	95	30	11,2	529	1	1	89,51
950103101600200	M16	2	102	30	12,5	529	1	1	125,29

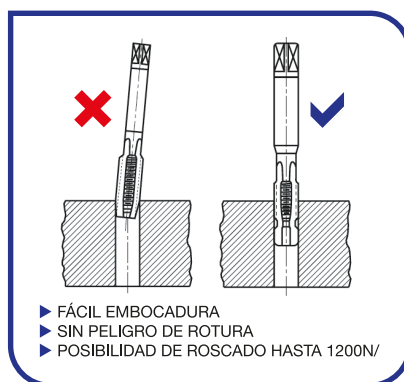

MACHOS & COJINETES
CORE HOLE DRILLING

Ref.
101



JUEGO DE 3 MACHOS DE MANO HSS DIN 352 | UNC | AGUJERO PASANTE/CIEGO | APLICACIÓN: ACEROS BLANDOS HASTA 400 N/mm²
 SET OF 3 HSS DIN 352 HAND TAPS | UNC | THROUGH/BLIND HOLE | APPLICATION: SOFT STEELS UP TO 400 N/mm²

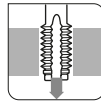
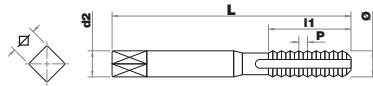

Aceros débilmente aleados <400 N/mm²
 Low alloyed steels <400N/mm²

9521011	Ø	P	L	I	d2	DIN	QTY	PCB	€
952101100001640	N°1	64	32	10	2,5	352	1	1	66,77
952101100002560	N°2	56	36	10	2,8	352	1	1	51,33
952101100003480	N°3	48	40	11	3,5	352	1	1	50,33
952101100004400	N°4	40	40	11	3,5	352	1	1	43,89
952101100005400	N°5	40	40	11	3,5	352	1	1	41,97
952101100006320	N°6	32	45	13	4	352	1	1	41,97
952101100008320	N°8	32	45	13	4	352	1	1	41,97
952101100010240	N°10	24	50	16	6	352	1	1	41,15
952101100012240	N°12	24	50	18	6	352	1	1	41,15
952101100140200	1/4	20	56	22	6	352	1	1	34,92
952101100516180	5/16	18	63	25	6	352	1	1	40,41
952101100380160	3/8	16	70	28	7	352	1	1	45,57
952101100716140	7/16	14	75	30	8	352	1	1	59,34
952101100120130	1/2	13	80	32	9	352	1	1	68,31
952101100916120	9/16	12	80	32	11	352	1	1	79,05
952101100580110	5/8	11	90	36	12	352	1	1	110,11
952101100340100	3/4	10	105	40	14	352	1	1	148,45
952101100780090	7/8	9	110	45	18	352	1	1	182,87
952101110000080	1"	8	110	50	20	352	1	1	246,95
952101110180070	1"1/8	7h	132	56	22	352	1	1	314,99
953102110140110	1"1/4	7h	132	56	22	352	1	1	396,47
952101110380060	1"3/8	6h	150	63	28	352	1	1	502,98
952101110120060	1"1/2	6h	150	63	32	352	1	1	617,55

● Ampliación de gama | Extended range

Ref.
102



JUEGO DE 2 MACHOS DE MANO HSS DIN 2181 | UNF | AGUJERO PASANTE/CIEGO | APLICACIÓN: ACEROS BLANDOS HASTA 400 N/mm²
 SET OF 3 HSS DIN 2181 HAND TAPS | UNF | THROUGH/BLIND HOLE | APPLICATION: SOFT STEELS UP TO 400 N/mm²

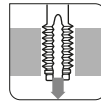
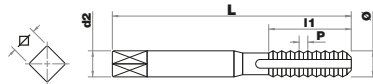

Aceros débilmente aleados <400 N/mm²
 Low alloyed steels <400N/mm²

9521021	Ø	P	L	I	d2	DIN	QTY	PCB	€
952102100000800	N°0	80	28	8	2,5	2181	1	1	40,72
952102100001720	N°1	72	32	9	2,8	2181	1	1	40,72
952102100003560	N°3	56	40	11	3,5	2181	1	1	47,34
952102100004480	N°4	48	40	11	3,5	2181	1	1	32,71
952102100005440	N°5	44	40	11	3,5	2181	1	1	32,71
952102100006400	N°6	40	45	13	4	2181	1	1	31,23
952102100008360	N°8	36	45	13	4	2181	1	1	31,23
952102100010320	N°10	32	50	16	6	2181	1	1	31,55
952102100012280	N°12	28	50	18	6	2181	1	1	32,71
952102100140280	1/4	28	56	22	6	2181	1	1	23,62
952102100516240	5/16	24	63	25	6	2181	1	1	25,82
952102100380240	3/8	24	70	25	7	2181	1	1	29,23
952102100716200	7/16	20	75	30	8	2181	1	1	38,80
952102100120200	1/2	20	80	32	9	2181	1	1	39,67
952102100916180	9/16	18	90	32	12	2181	1	1	51,71
952102100580180	5/8	18	90	32	12	2181	1	1	66,77
952102100340160	3/4	16	105	35	14	2181	1	1	89,71
952102100780140	7/8	14	110	35	18	2181	1	1	115,27
952102110000120	1"	12	110	35	20	2181	1	1	151,37
952102110180120	1"1/8	12	110	50	22	2181	1	1	185,46
952102110140120	1"1/4	12	132	56	22	2181	1	1	226,50
952102110380120	1"3/8	12	132	56	28	2181	1	1	305,57
952102110120120	1"1/2	12	150	63	32	2181	1	1	386,04

● Ampliación de gama | Extended range

MACHOS & COJINETES
CORE HOLE DRILLING

Ref.
101



JUEGO DE 3 MACHOS DE MANO HSS DIN 352 | BSW | AGUJERO PASANTE/CIEGO | APLICACIÓN: ACEROS BLANDOS HASTA 400 N/mm²

SET OF 3 HSS DIN 352 HAND TAPS | BSW | THROUGH/BLIND HOLE | APPLICATION: SOFT STEELS UP TO 400 N/mm²

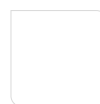
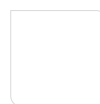
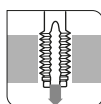
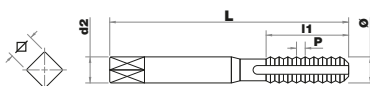

Aceros débilmente aleados <400 N/mm²
Low alloyed steels <400N/mm²

9511011	Ø	P	L	I	d2	DIN	QTY	PCB	€
951101100180400	1/8	40	40	11	3.5	352	1	1	24,28
951101100532320	5/32	32	45	13	4,5	352	1	1	24,28
951101100316240	3/16	24	50	16	6	352	1	1	24,28
951101100732240	7/32	24	50	18	6	352	1	1	36,05
951101100140200	1/4	20	56	22	6	352	1	1	27,62
951101100516180	5/16	18	63	25	6	352	1	1	32,86
951101100380160	3/8	16	70	28	7	352	1	1	36,33
951101100716140	7/16	14	75	30	8	352	1	1	47,62
951101100120120	1/2	12	80	32	9	352	1	1	52,61
951101100916120	9/16	12	80	32	9	352	1	1	69,63
951101100580110	5/8	11	90	36	12	352	1	1	81,34
951101100340100	3/4	10	105	40	14	352	1	1	116,29
951101100780090	7/8	9	110	45	18	352	1	1	144,90
951101110000080	1"	8	110	50	20	352	1	1	177,58
951101110140070	1 1/4"	7	125	56	25	352	1	1	315,31

Ref.
102



JUEGO DE 2 MACHOS DE MANO HSS DIN 2181 | BSF | AGUJERO PASANTE/CIEGO | APLICACIÓN: ACEROS BLANDOS HASTA 400 N/mm²

SET OF 3 HSS DIN 2181 HAND TAPS | BSF | THROUGH/BLIND HOLE | APPLICATION: SOFT STEELS UP TO 400 N/mm²

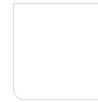
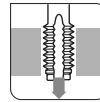
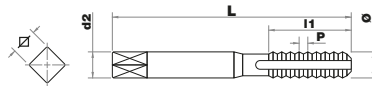

Aceros débilmente aleados <400 N/mm²
Low alloyed steels <400N/mm²

9511021	Ø	P	L	I	d2	DIN	QTY	PCB	€
951102100140260	1/4	26	56	22	6	2181	1	1	35,15
951102100380200	3/8	20	70	28	7	2181	1	1	47,86
951102100716180	7/16	18	75	30	8	2181	1	1	56,85
951102100120160	1/2	16	80	32	9	2181	1	1	64,32
951102100916160	9/16	16	80	32	11	2181	1	1	77,11
951102100780110	7/8	11	110	45	14,5	2181	1	1	184,10
951102110000100	1"	10	110	50	20	2181	1	1	258,40

MACHOS & COJINETES
CORE HOLE DRILLING

Ref.
102



JUEGO DE 2 MACHOS DE MANO HSS DIN 5157 | BSP GAS | AGUJERO PASANTE/CIEGO | APLICACIÓN: ACEROS BLANDOS HASTA 400 N/mm²

SET OF 3 HSS DIN 5157 HAND TAPS | BSP | THROUGH/BLIND HOLE | APPLICATION: SOFT STEELS UP TO 400 N/mm²

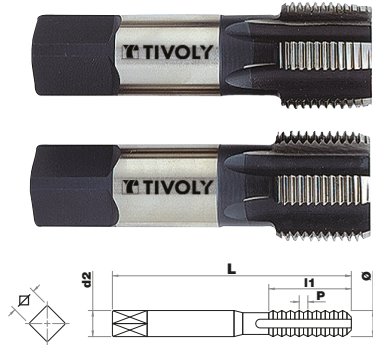

HSS

BRIGHT UNCOATED

DIN 5157

x2 SET

BSP G

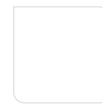
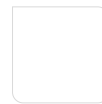

A

Aceros débilmente aleados <400 N/mm²
Low alloyed steels <400N/mm²

9531021	Ø	P	L	I	d2	DIN	QTY	PCB	€
953102100180280	1/8	28	63	18	7	5157	1	1	29,22
953102100140190	1/4	19	70	20	11	5157	1	1	41,15
953102100380190	3/8	19	70	20	12	5157	1	1	51,68
953102100120140	1/2	14	80	22	16	5157	1	1	72,50
953102100580140	5/8	14	80	22	18	5157	1	1	92,79
953102100340140	3/4	14	90	22	20	5157	1	1	113,18
953102100780140	7/8	14	90	22	22	5157	1	1	150,93
953102110000110	1"	11	100	25	25	5157	1	1	179,45
953102110180110	1 1/8"	11	125	32	28	5157	1	1	255,69
953102110140110	1 1/4"	11	125	32	32	5157	1	1	281,41
953102110380110	1 3/8"	11	125	32	36	5157	1	1	378,45
953102110120110	1 1/2"	11	140	32	36	5157	1	1	425,30
953102120000110	2"	11	160	36	45	5157	1	1	776,05

MACHOS & COJINETES
CORE HOLE DRILLING

Ref.
102



JUEGO DE 2 MACHOS DE MANO HSS DIN 5157 | BSP GAS ROSCADO IZQUIERDA | AGUJERO PASANTE/CIEGO | APLICACIÓN: ACEROS BLANDOS HASTA 400 N/mm²

SET OF 3 HSS DIN 5157 HAND TAPS | BSP LEFT HAND | THROUGH/BLIND HOLE | APPLICATION: SOFT STEELS UP TO 400 N/mm²

HSS

BRIGHT UNCOATED

DIN 5157

x2 SET

BSP G



9531061	Ø	P	L	I	d2	DIN	QTY	PCB	€
953106100180280	1/8"	28h	63	20	7	5157	1	1	44,65
953106100140190	1/4"	19h	70	22	11	5157	1	1	62,92
953106100380190	3/8"	19h	70	22	12	5157	1	1	78,98
953106100120140	1/2"	14h	80	22	16	5157	1	1	110,77
953106100580140	5/8"	14h	80	22	18	5157	1	1	141,73
953106100340140	3/4"	14h	90	22	20	5157	1	1	172,91
953106110000110	1"	11h	100	25	25	5157	1	1	274,12

● Ampliación de gama | Extended range



MACHOS Y COJINETES DE ROSCAR

TAPPING & THREADING

CATÁLOGO GENERAL
2021

- **MACHOS MÁQUINA M-MF** **106**
REGULAR - MACHINE TAP
M-MF
- **MACHOS MÁQUINA UNC-UNF** **116**
REGULAR - MACHINE TAP
UNC-UNF
- **MACHOS MÁQUINA BSW-BSF** **120**
REGULAR - MACHINE TAP
BSW-BSF
- **MACHOS MÁQUINA BSP GAS** **122**
REGULAR - MACHINE TAP
BSP GAS
- **MACHOS MÁQUINA NPT** **124**
REGULAR - MACHINE TAP
NPT

Ref.
201



**MACHO DE MÁQUINA ACERO COBALTO 5% (HSSE) |
MÉTRICO/MÉTRICO FINO | AGUJERO PASANTE/CIEGO |
APLICACIÓN: ACEROS SEMI-DUROS HASTA 700 N/mm²**

COBALT STEEL 5% MACHINE TAP (HSSE) | METRIC/METRIC FINE |
THROUGH/BLIND HOLE | APPLICATION: SEMI-HARD STEELS UP TO 700N/mm²

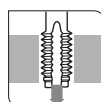
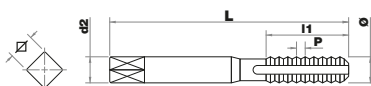

Aceros débilmente aleados <400 N/mm²
Low alloyed steels <400N/mm²



Aceros aleados y tratados < 700N/mm²
Heat Treatable Steels <700N/mm²

9602011	Ø	P	L	I	d2	DIN	QTY	PCB	€
960201100200040	M2	0,4	45	8	2,8	371	1	1	16,30
960201100250045	M2,5	0,45	50	9	2,8	371	1	1	16,57
960201100260045	M2,6	0,45	50	9	2,8	371	1	1	16,57
960201100300050	M3	0,5	56	10	3,5	371	1	1	12,42
960201100350060	M3,5	0,6	56	11	4	371	1	1	14,91
960201100400070	M4	0,7	63	12	4,5	371	1	1	12,61
960201100500080	M5	0,8	70	14	6	371	1	1	12,61
960201100600100	M6	1	80	16	6	371	1	1	14,36
960201100800125	M8	1,25	90	18	8	371	1	1	16,11
960201101000150	M10	1,5	100	20	10	371	1	1	18,42

9602011	Ø	P	L	I	d2	DIN	QTY	PCB	€
960201100400050	MF4	0,5	63	10	4,5	371	1	1	23,61
960201100500050	MF5	0,5	70	11	6	371	1	1	23,86
960201100700075	MF7	0,75	80	16	7	371	1	1	25,04
960201100800075	MF8	0,75	90	18	8	371	1	1	23,35
960201100800100	MF8	1	90	18	8	371	1	1	19,43
960201101000100	MF10	1	100	20	10	371	1	1	21,13
960201101000125	MF10	1,25	100	20	10	371	1	1	24,68

MACHOS & COJINETES
CORE HOLE DRILLING

Ref.
301



MACHO DE MÁQUINA ACERO COBALTO 5% (HSSE) | MÉTRICO/MÉTRICO FINO | AGUJERO PASANTE/CIEGO | APLICACIÓN: ACEROS SEMI-DUROS HASTA 700 N/mm²

COBALT STEEL 5% MACHINE TAP (HSSE) | METRIC/METRIC FINE | THROUGH/BLIND HOLE | APPLICATION: SEMI-HARD STEELS UP TO 700N/mm²

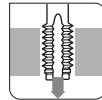
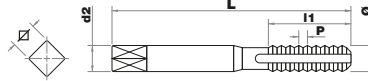

Aceros débilmente aleados <400 N/mm²
Low alloyed steels <400N/mm²



Aceros aleados y tratados < 700N/mm²
Heat Treatable Steels <700N/mm²

9603011	Ø	P	L	I	d2	DIN	QTY	PCB	€
960301100300050	M3	0,4	45	8	2,2	376	1	1	12,68
960301100400070	M4	0,7	63	12	2,8	376	1	1	12,93
960301100500080	M5	0,8	70	14	3,5	376	1	1	12,93
960301100600100	M6	1	80	16	4,5	376	1	1	14,90
960301100800125	M8	1,25	90	18	6	376	1	1	16,74
960301101000150	M10	1,5	100	20	7	376	1	1	19,08
960301101200175	M12	1,75	110	22	9	376	1	1	23,79
960301101400200	M14	2	10	25	11	376	1	1	30,68
960301101600200	M16	2	110	28	12	376	1	1	36,81
960301102000250	M20	2,5	140	32	16	376	1	1	56,33
960301102400300	M24	3	160	32	18	376	1	1	81,64
960301103000350	M30	3,5	180	40	22	376	1	1	130,57
960301103300350	M33	3,5	180	40	25	376	1	1	155,39
960301103600400	M36	4	200	45	28	376	1	1	198,19
960301103900400	M39	4	200	45	32	376	1	1	253,58
960301104200450	M42	4,5	200	50	32	376	1	1	329,35
960301104500450	M45	4,5	220	50	36	376	1	1	356,19
960301104800500	M48	5	250	56	36	376	1	1	438,00

9603011	Ø	P	L	I	d2	DIN	QTY	PCB	€
960301100600075	MF6	0,75	80	12	4,5	376	1	1	19,61
960301100800100	MF8	1	90	18	8	374	1	1	20,16
960301101000100	MF10	1	90	18	7	374/6	1	1	22,33
960301101000125	MF10	1,25	100	20	7	374/6	1	1	29,49
960301101200100	MF12	1	100	22	9	374/6	1	1	29,49
960301101200125	MF12	1,25	100	22	9	374/6	1	1	29,24
960301101200150	MF12	1,5	100	22	9	374/6	1	1	26,70
960301101300100	MF13	1	100	22	9	374/6	1	1	52,17
960301101400100	MF14	1	100	22	11	374/6	1	1	44,42
960301101400150	MF14	1,5	100	22	11	374/6	1	1	31,51
960301101500100	MF15	1	100	22	11	374/6	1	1	58,63
960301101600100	MF16	1	100	22	12	374/6	1	1	56,33
960301101600125	MF16	1,25	100	22	12	374/6	1	1	61,50
960301101600150	MF16	1,5	110	22	12	374/6	1	1	39,41
960301101800150	MF18	1,5	110	22	12	374/6	1	1	49,29
960301102000100	MF20	1	125	25	14	374/6	1	1	82,48
960301102000150	MF20	1	125	25	16	374/6	1	1	55,78
960301102200100	MF22	1	125	25	18	374/6	1	1	96,14
960301102200150	MF22	1,5	125	25	18	374/6	1	1	67,22
960301102400200	MF24	2	140	25	18	374/6	1	1	105,40
960301102500150	MF25	1,5	140	25	18	374/6	1	1	128,54
960301102700200	MF27	2	140	25	18	374/6	1	1	144,75
960301103000200	MF30	2	150	32	22	374/6	1	1	156,94
960301103200150	MF32	1,5	150	28	28	374/6	1	1	160,41
960301103600150	MF36	1,5	170	32	28	374/6	1	1	208,84
960301104000150	MF40	1,5	170	32	32	374/6	1	1	280,04

MACHOS & COJINETES
CORE HOLE DRILLING

Ref.
252
352



MACHO DE MÁQUINA ACERO COBALTO 5% (HSSE5) | MÉTRICO/MÉTRICO FINO | AGUJERO PASANTE | APLICACIÓN: ACEROS SEMI-DUROS HASTA 700 N/mm²

COBALT STEEL 5% (HSSE5) MACHINE TAP | METRIC/ METRIC FINE | THROUGH HOLE | APPLICATION: SEMI-HARD STEELS UP TO 700 N/mm²

MANGO REFORZADO

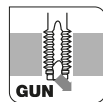
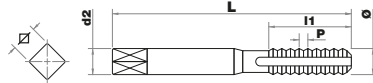

Aceros débilmente aleados <400 N/mm²
Low alloyed steels <400N/mm²



Aceros aleados y tratados < 700N/mm²
Heat Treatable Steels <700N/mm²

1602521	Ø	P	L	I	d2	DIN	QTY	PCB	€
160252100200040	M2	0,40	45	8	2,8	371	1	1	12,33
160252100250045	M2,5	0,45	50	9	2,8	371	1	1	12,33
160252100300050	M3	0,50	56	10	3,5	371	1	1	9,71
160252100400070	M4	0,70	63	12	4,5	371	1	1	9,93
160252100500080	M5	0,80	70	14	6	371	1	1	9,93
160252100600100	M6	1	80	16	6	371	1	1	10,86
160252100800125	M8	1,25	90	18	8	371	1	1	12,22
160252101000150	M10	1,5	100	20	10	371	1	1	15,04

1602521	Ø	P	L	I	d2	DIN	QTY	PCB	€
160252100800100	MF8	1	90	16	8	371	1	1	14,89
160252101000100	MF10	1	100	18	10	371	1	1	16,61

MANGO DELGADO



1603521	Ø	P	L	I	d2	DIN	QTY	PCB	€
160352101200175	M12	1,75	110	22	9	376	1	1	19,10
160352101400200	M14	2	110	25	11	376	1	1	25,54
160352101600200	M16	2	110	28	12	376	1	1	31,89
160352101800250	M18	2,5	125	32	14	376	1	1	51,13
160352102000250	M20	2,5	140	32	16	376	1	1	52,16
160352102400300	M24	3	160	32	18	376	1	1	70,76
160352102700300	M27	3	160	36	20	376	1	1	99,56
160352103000350	M30	3,5	180	40	22	376	1	1	113,74
160352103300350	M33	3,5	180	40	25	376	1	1	160,93

1603521	Ø	P	L	I	d2	DIN	QTY	PCB	€
160352101200150	MF12	1,5	100	22	9	374	1	1	26,15
160352101400150	MF14	1,5	100	22	11	374	1	1	32,63

Ref.
222



MACHO DE MÁQUINA ACERO COBALTO 5% (HSSE) | MÉTRICO | AGUJERO PASANTE | TOLERANCIA 6G | APLICACIÓN: ACEROS SEMI-DUROS HASTA 700 N/mm²

COBALT STEEL 5% (HSSE) MACHINE TAP | METRIC | THROUGH HOLE | **6G TOLERANCE** | APPLICATION: SEMI-HARD STEELS UP TO 700 N/mm²

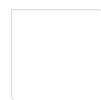
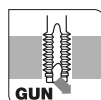
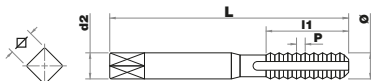

Aceros débilmente aleados <400 N/mm²
Low alloyed steels <400N/mm²



Aceros aleados y tratados < 700N/mm²
Heat Treatable Steels <700N/mm²

9602221	Ø	P	L	I	d2	DIN	QTY	PCB	€
960222100300050	M3	0,50	56	10	3,5	371	1	1	13,10
960222100400070	M4	0,70	63	12	4,5	371	1	1	13,41
960222100500080	M5	0,80	70	14	6	371	1	1	13,41
960222100600100	M6	1	80	16	6	371	1	1	14,66
960222100800125	M8	1,25	90	18	8	371	1	1	16,50
960222101000150	M10	1,5	100	20	10	371	1	1	20,31
960322101200175	M12	1,75	110	22	9	371	1	1	25,78

MACHOS & COJINETES
CORE HOLE DRILLING

Ref.
002



MACHO DE MÁQUINA ACERO COBALTO 5% (HSSE) | MÉTRICO | AGUJERO PASANTE | ROSCA IZQUIERDA | APLICACIÓN: ACEROS SEMI-DUROS HASTA 700 N/mm²

COBALT STEEL 5% (HSSE) MACHINE TAP | METRIC | THROUGH HOLE | **LEFT HAND THREAD** | APPLICATION: SEMI-HARD STEELS UP TO 700 N/mm²

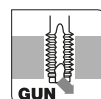
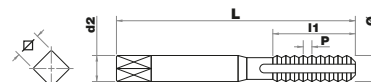

Aceros débilmente aleados <400 N/mm²
Low alloyed steels <400N/mm²



Aceros aleados y tratados < 700N/mm²
Heat Treatable Steels <700N/mm²

9600021	Ø	P	L	I	d2	DIN	QTY	PCB	€
960002100300050	M3	0,50	56	10	3,5	371	1	1	24,32
960002100400070	M4	0,70	63	12	4,5	371	1	1	24,90
960002100500080	M5	0,80	70	14	6	371	1	1	24,90
960002100600100	M6	1	80	16	6	371	1	1	27,22
960002100800125	M8	1,25	90	18	8	371	1	1	30,63
960002101000150	M10	1,5	100	20	10	371	1	1	37,70
960012101200175	M12	1,75	110	22	9	371	1	1	47,86

Ref.
255



MACHO DE MÁQUINA ACERO COBALTO 5% (HSSE) | HELICOIDAL 35°
| MÉTRICO/MÉTRICO FINO | AGUJERO CIEGO | APLICACIÓN:
ACEROS SEMI-DUROS HASTA 700 N/mm²

COBALT STEEL 5% (HSSE) MACHINE TAP | SPIRAL FLUTE 35° |
 METRIC/ METRIC FINE | BLIND HOLE | APPLICATION: SEMI-HARD STEELS UP
 TO 700 N/mm²

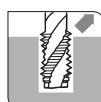
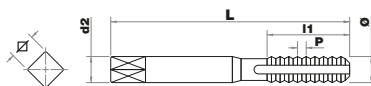

Aceros débilmente
aleados <400 N/mm²
Low alloyed
steels <400N/mm²



Aceros aleados y
tratados < 700N/mm²
Heat Treatable
Steels <700N/mm²

1602551	Ø	P	L	I	d2	DIN	QTY	PCB	€
160255100200040	M2	0,4	45	8	2,8	371	1	1	15,21
160255100250045	M2,5	0,45	50	5	2,8	371	1	1	25,08
160255100300050	M3	0,5	50	5	3,5	371	1	1	11,45
160255100400070	M4	0,7	63	7	4,5	371	1	1	11,47
160255100500080	M5	0,8	70	9	6	371	1	1	11,00
160255100600100	M6	1	80	10	6	371	1	1	12,09
160255100800125	M8	1,25	90	12	8	371	1	1	14,39
160255101000150	M10	1,5	100	14	10	371	1	1	17,11

1602551	Ø	P	L	I	d2	DIN	QTY	PCB	€
160255100800100	MF8	1	90	10	8	371	1	1	17,68
160255101000100	MF10	1	100	14	10	371	1	1	20,82



1603551	Ø	P	L	I	d2	DIN	QTY	PCB	€
160355101200175	M12	1,75	110	16	9	376	1	1	22,66
160355101400200	M14	2	110	18	11	376	1	1	29,65
160355101600200	M16	2	110	18	12	376	1	1	38,21
160355101800250	M18	2,5	125	25	14	376	1	1	57,87
160355102000250	M20	2,5	140	25	16	376	1	1	58,32
160355102400300	M24	3	160	30	18	376	1	1	82,01
160355102700300	M27	3	160	30	20	376	1	1	113,55
160355103000350	M30	3,5	180	35	22	376	1	1	129,32
160355103300350	M33	3,5	180	40	25	376	1	1	182,12

1603551	Ø	P	L	I	d2	DIN	QTY	PCB	€
160355101200150	MF12	1,5	100	14	9	374	1	1	31,55
160355101400150	MF14	1,50	100	18	11	374	1	1	40,89

MACHOS & COJINETES
CORE HOLE DRILLING

Ref.
225



MACHO DE MÁQUINA ACERO COBALTO 5% (HSSE) | HELICOIDAL 35°
| MÉTRICO | AGUJERO CIEGO | TOLERANCIA 6G
 COBALT STEEL 5% (HSSE) MACHINE TAP | SPIRAL FLUTE 35° | METRIC | BLIND HOLE | **6G TOLERANCE**

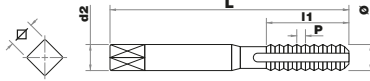

Aceros débilmente aleados <400 N/mm²
 Low alloyed steels <400N/mm²



Aceros aleados y tratados < 700N/mm²
 Heat Treatable Steels <700N/mm²

9602251	Ø	P	L	I	d2	DIN	QTY	PCB	€
960225100300050	M3	0,5	50	5	3,5	371	1	1	15,46
960225100400070	M4	0,7	63	7	4,5	371	1	1	15,49
960225100500080	M5	0,8	70	9	6	371	1	1	15,49
960225100600100	M6	1	80	10	6	371	1	1	16,33
960225100800125	M8	1,25	90	12	8	371	1	1	19,43
960225101000150	M10	1,5	100	14	10	371	1	1	23,08
960325101200175	M12	1,75	110	16	9	376	1	1	30,58

MACHOS & COJINETES
CORE HOLE DRILLING

Ref.
005



MACHO DE MÁQUINA ACERO COBALTO 5% (HSSE) | HELICOIDAL 35°
| MÉTRICO | AGUJERO CIEGO | ROSCA IZQUIERDA
 COBALT STEEL 5% (HSSE) MACHINE TAP | SPIRAL FLUTE 35° | METRIC | BLIND HOLE | **LEFT HAND THREAD**

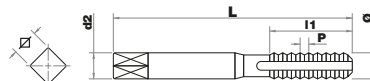

Aceros débilmente aleados <400 N/mm²
 Low alloyed steels <400N/mm²



Aceros aleados y tratados < 700N/mm²
 Heat Treatable Steels <700N/mm²

9600051	Ø	P	L	I	d2	DIN	QTY	PCB	€
960005100300050	M3	0,5	50	5	3,5	371	1	1	29,80
960005100400070	M4	0,7	63	7	4,5	371	1	1	29,85
960005100500080	M5	0,8	70	9	6	371	1	1	29,85
960005100600100	M6	1	80	10	6	371	1	1	31,47
960005100800125	M8	1,25	90	12	8	371	1	1	37,45
960005101000150	M10	1,5	100	14	10	371	1	1	44,51
960015101200175	M12	1,75	110	16	9	376	1	1	58,97

Ref.
008



MACHO DE MÁQUINA HSS | MÉTRICO | AGUJERO PASANTE |

APLICACIÓN: ACEROS BLANDOS HASTA 400 N/mm²

HSS MACHINE TAP | METRIC | THROUGH HOLE | APPLICATION: SOFT STEELS UP TO 400 N/mm²

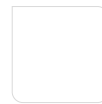
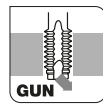
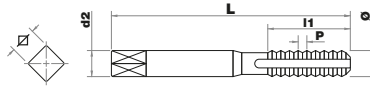

Aceros débilmente aleados <400 N/mm²
Low alloyed steels <400N/mm²

1050081	Ø	P	L	I	d2	DIN	QTY	PCB	€
1050081030050	M3	0,5	56	10	3,5	371	1	1	6,82
1050081040070	M4	0,7	63	12	4,5	371	1	1	6,82
1050081050080	M5	0,8	70	14	6	371	1	1	7,11
1050081060100	M6	1	80	16	6	371	1	1	7,43
1050081080125	M8	1,25	90	18	8	371	1	1	9,18
1050081100150	M10	1,5	100	20	10	371	1	1	11,33
1050081120175	M12	1,75	110	22	9	376	1	1	13,20
1050081140200	M14	2	110	25	11	376	1	1	17,13
1050081160200	M16	2	110	28	12	376	1	1	19,26
1050081180250	M18	2,5	125	32	14	376	1	1	27,05
1050081200250	M20	2,5	140	32	16	376	1	1	37,42

MACHOS & COJINETES
CORE HOLE DRILLING

Ref.
010



MACHO DE MÁQUINA HSS | HELICOIDAL 35° | MÉTRICO | AGUJERO CIEGO | APLICACIÓN: ACEROS BLANDOS HASTA 400 N/mm²

HSS MACHINE TAP | SPIRAL FLUTE 35° | METRIC | BLIND HOLE | APPLICATION: SOFT STEELS UP TO 400 N/mm²

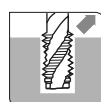
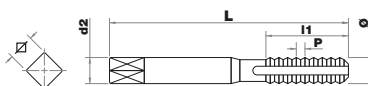

Aceros débilmente aleados <400 N/mm²
Low alloyed steels <400N/mm²

1050101	Ø	P	L	I	d2	DIN	QTY	PCB	€
1050101030050	M3	0,5	56	5	3,5	371	1	1	7,43
1050101040070	M4	0,7	63	7	4,5	371	1	1	7,43
1050101050080	M5	0,8	70	9	6	371	1	1	7,80
1050101060100	M6	1	80	10	6	371	1	1	8,15
1050101080125	M8	1,25	90	12	8	371	1	1	9,90
1050101100150	M10	1,5	100	14	10	371	1	1	12,40
1050101120175	M12	1,75	110	16	9	376	1	1	14,48
1050101140200	M14	2	110	18	11	376	1	1	18,68
1050101160200	M16	2	110	18	12	376	1	1	21,02
1050101180250	M18	2,5	125	25	14	376	1	1	29,80
1050101200250	M20	2,5	140	25	16	376	1	1	41,21

MACHOS & COJINETES
CORE HOLE DRILLING

Ref.
460



MACHO DE MÁQUINA LARGO ACERO COBALTO 5% (HSSE) | MÉTRICO | AGUJERO PASANTE/CIEGO | APLICACIÓN: ACEROS SEMI-DUROS HASTA 700 N/mm²

COBALT STEEL 5% (HSSE) LONG MACHINE TAP | METRIC | THROUGH/BLIND HOLE | APPLICATION: SEMI-HARD STEELS UP TO 700 N/mm²

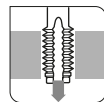
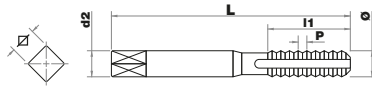

Aceros débilmente aleados <400 N/mm²
Low alloyed steels <400N/mm²



Aceros aleados y tratados < 700N/mm²
Heat Treatable Steels <700N/mm²

9704601	Ø	P	L	I	d2	NFE	QTY	PCB	€
970460100300050	M3	0.5	90	19	2.1	66112	1	1	122,44
970460100400070	M4	0.7	100	20	2.9	66112	1	1	70,84
970460100500080	M5	0.8	110	25	3.7	66112	1	1	79,99
970460100600100	M6	1	120	27	4.5	66112	1	1	79,99
970460100800125	M8	1.25	135	32	6.2	66112	1	1	106,46
970460101000150	M10	1.5	150	38	7.6	66112	1	1	114,34
970460101200175	M12	1.75	165	43	9	66112	1	1	121,54
970460101400200	M14	2	180	50	10.5	66112	1	1	174,79
970460101600200	M16	2	190	50	12.5	66112	1	1	174,79

MACHOS & COJINETES
CORE HOLE DRILLING

Ref.
461



**MACHO DE MÁQUINA LARGO ACERO COBALTO 5% (HSSE) |
ENTRADA CORREGIDA | MÉTRICO | AGUJERO PASANTE |
APLICACIÓN: ACEROS SEMI-DUROS HASTA 700 N/mm²**

COBALT STEEL 5% (HSSE) LONG MACHINE TAP | METRIC | THROUGH HOLE |
APPLICATION: SEMI-HARD STEELS UP TO 700 N/mm²

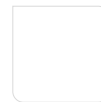
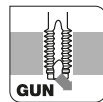
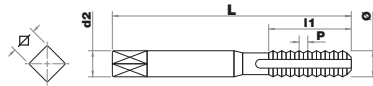

Aceros débilmente aleados <400 N/mm²
Low alloyed steels <400N/mm²



Aceros aleados y tratados < 700N/mm²
Heat Treatable Steels <700N/mm²

9704611	Ø	P	L	I	d2	NFE	QTY	PCB	€
970461100300050	M3	0.5	90	19	2.1	66112	1	1	76,24
970461100400070	M4	0.7	100	20	2.9	66112	1	1	83,44
970461100500080	M5	0.8	110	25	3.7	66112	1	1	80,84
970461100600100	M6	1	120	27	4.5	66112	1	1	80,84
970461100800125	M8	1.25	135	32	6.2	66112	1	1	95,80
970461101000150	M10	1.5	150	38	7.6	66112	1	1	111,47
970461101200175	M12	1.75	165	43	9	66112	1	1	121,54

MACHOS & COJINETES
CORE HOLE DRILLING

Ref.
202



MACHO DE MÁQUINA ACERO COBALTO 5% (HSSE) | UNC/UNF | AGUJERO PASANTE | APLICACIÓN: ACEROS SEMI-DUROS HASTA 700 N/mm²

COBALT STEEL 5% (HSSE) MACHINE TAP | UNC/UNF | THROUGH HOLE | APPLICATION: SEMI-HARD STEELS UP TO 700N/mm²

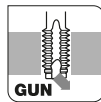
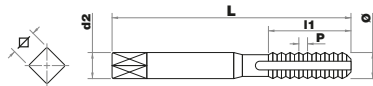

Aceros débilmente aleados <400 N/mm²
Low alloyed steels <400N/mm²



Aceros aleados y tratados < 700N/mm²
Heat Treatable Steels <700N/mm²

9622021	Ø	P	L	I	d2	DIN	QTY	PCB	€
962202100004400	UNC N°4	40	56	11	3.5	371	1	1	23,65
962202100005400	UNC N°5	40	56	11	3.5	371	1	1	23,89
962202100006320	UNC N°6	32	56	11	4	371	1	1	22,75
962202100008320	UNC N°8	32	63	12	4.5	371	1	1	22,75
962202100010240	UNC N°10	24	70	14	6	371	1	1	23,89
962202100012240	UNC N°12	24	80	14	6	371	1	1	22,69
962202100140200	UNC 1/4	20	80	16	7	371	1	1	20,34
962202100516180	UNC 5/16	18	90	18	8	371	1	1	23,35
962202100380160	UNC 3/8	16	90	18	9	371	1	1	26,65

9622021	Ø	P	L	I	d2	DIN	QTY	PCB	€
962202100010320	UNF N°10	32	70	14	6	371	1	1	25,03
962202100012280	UNF N°12	28	80	17	6	371	1	1	25,90
962202100140280	UNF 1/4	28	80	16	7	371	1	1	21,22
962202100516240	UNF 5/16	24	90	18	8	371	1	1	24,24
962202100380240	UNF 3/8	24	100	18	9	371	1	1	27,50

MACHOS & COJINETES
CORE HOLE DRILLING

Ref.
302



MACHO DE MÁQUINA ACERO COBALTO 5% (HSSE) | UNC/UNF | AGUJERO PASANTE | APLICACIÓN: ACEROS SEMI-DUROS HASTA 700 N/mm²

COBALT STEEL 5% (HSSE5) MACHINE TAP | UNC/UNF | THROUGH HOLE | APPLICATION: SEMI-HARD STEELS UP TO 700N/mm²

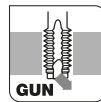
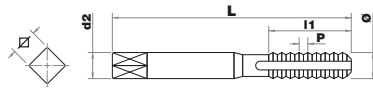

Aceros débilmente aleados <400 N/mm²
Low alloyed steels <400N/mm²



Aceros aleados y tratados < 700N/mm²
Heat Treatable Steels <700N/mm²

9623021	Ø	P	L	I	d2	DIN	QTY	PCB	€
962302100140200	UNC 1/4	20	80	16	4.5	376	1	1	24,13
962302100516180	UNC 5/16	18	90	18	6	376	1	1	27,61
962302100380160	UNC 3/8	16	90	18	7	376	1	1	31,66
962302100716140	UNC 7/16	14	100	22	8	376	1	1	34,54
962302100120130	UNC 1/2	13	110	25	9	376	1	1	36,74
962302100580110	UNC 5/8	11	110	28	12	376	1	1	50,74
962302100340100	UNC 3/4	10	125	32	14	376	1	1	65,03
962302100780090	UNC 7/8	9	140	32	18	376	1	1	80,97
962302110000080	UNC 1"	8	160	36	20	376	1	1	106,07

9623021	Ø	P	L	I	d2	DIN	QTY	PCB	€
962302100380240	UNF 3/8	24	100	18	7	376	1	1	29,36
962302100716200	UNF 7/16	20	100	22	8	376	1	1	37,49
962302100120200	UNF 1/2	20	110	25	9	376	1	1	41,52
962302100580180	UNF 5/8	18	110	25	12	376	1	1	55,08
962302100340160	UNF 3/4	16	125	32	14	376	1	1	72,88
962302100780140	UNF 7/8	14	125	32	18	376	1	1	94,84
962302110000120	UNF 1"	12	140	32	20	376	1	1	125,89

MACHOS & COJINETES
CORE HOLE DRILLING

Ref.
205



MACHO DE MÁQUINA ACERO COBALTO 5% (HSSE) | HELICOIDAL 35°
| UNC/UNF | AGUJERO CIEGO | APLICACIÓN: ACEROS SEMI-DUROS
HASTA 700 N/mm²

COBALT STEEL 5% (HSSE) MACHINE TAP | SPIRAL FLUTE 35° | UNC/UNF |
 BLIND HOLE | APPLICATION: SEMI-HARD STEELS UP TO 700N/mm²

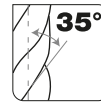
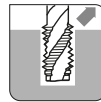
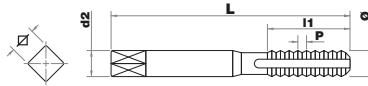

Aceros débilmente
aleados <400 N/mm²
Low alloyed
steels <400N/mm²



Aceros aleados y
tratados < 700N/mm²
Heat Treatable
Steels <700N/mm²

9622051	Ø	P	L	I	d2	DIN	QTY	PCB	€
962205100004400	UNC N°4	40	56	5	3.5	371	1	1	27,26
962205100006320	UNC N°6	32	56	7	4	371	1	1	25,93
962205100008320	UNC N°8	32	63	7	4.5	371	1	1	25,93
962205100010240	UNC N°10	24	70	10	6	371	1	1	27,26
962205100140200	UNC 1/4	20	80	12	7	371	1	1	23,09
962205100516180	UNC 5/16	18	90	12	8	371	1	1	26,59
962205100380160	UNC 3/8	19	90	14	9	371	1	1	30,61

9622051	Ø	P	L	I	d2	DIN	QTY	PCB	€
962205100010320	UNF N°10	32	70	9	6	371	1	1	32,21
962205100140280	UNF 1/4	28	80	10	7	371	1	1	24,48
962205100516240	UNF 5/16	24	90	12	8	371	1	1	27,61
962205100380240	UNF 3/8	24	100	14	9	371	1	1	30,93

MACHOS & COJINETES
CORE HOLE DRILLING

Ref.
305



MACHO DE MÁQUINA ACERO COBALTO 5% (HSSE) | HELICOIDAL 35°
| UNC/UNF | AGUJERO CIEGO | APLICACIÓN: ACEROS SEMI-DUROS
HASTA 700 N/mm²

COBALT STEEL 5% (HSSE) MACHINE TAP | SPIRAL FLUTE 35° | UNC/UNF |
 BLIND HOLE | APPLICATION: SEMI-HARD STEELS UP TO 700N/mm²

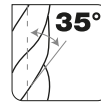
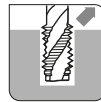
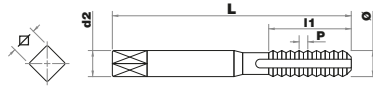

Aceros débilmente
aleados <400 N/mm²
Low alloyed
steels <400N/mm²



Aceros aleados y
tratados < 700N/mm²
Heat Treatable
Steels <700N/mm²

9623051	Ø	P	L	I	d2	DIN	QTY	PCB	€
962305100516180	UNC 5/16	18	90	12	6	376	1	1	31,43
962305100380160	UNC 3/8	16	90	14	7	376	1	1	35,53
962305100716140	UNC 7/16	14	100	16	8	376	1	1	39,25
962305100120130	UNC 1/2	13	110	16	9	376	1	1	41,72
962305100916120	UNC 9/16	12	110	18	11	376	1	1	51,21
962305100580110	UNC 5/8	11	110	20	12	376	1	1	57,72
962305100340100	UNC 3/4	10	125	25	14	376	1	1	73,86
962305100780090	UNC 7/8	9	140	28	18	376	1	1	128,46
962305110000080	UNC 1"	8	160	30	20	376	1	1	162,71

9623051	Ø	P	L	I	d2	DIN	QTY	PCB	€
962305100716200	UNF 7/16	20	100	14	8	376	1	1	43,35
962305100120200	UNF 1/2	20	110	16	9	376	1	1	47,39
962305100916180	UNF 9/16	18	110	18	11	376	1	1	63,72
962305100580180	UNF 5/8	18	110	18	12	376	1	1	62,58
962305100340160	UNF 3/4	16	125	18	14	376	1	1	82,89

MACHOS & COJINETES
CORE HOLE DRILLING

Ref.
202



MACHO DE MÁQUINA ACERO COBALTO 5% (HSSE) | BSW | AGUJERO PASANTE | APLICACIÓN: ACEROS SEMI-DUROS HASTA 700 N/mm²

COBALT STEEL 5% (HSSE) MACHINE TAP | BSW | THROUGH HOLE | APPLICATION: SEMI-HARD STEELS UP TO 700N/mm²

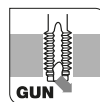
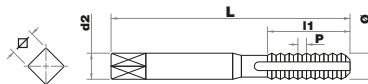

Aceros débilmente aleados <400 N/mm²
Low alloyed steels <400N/mm²



Aceros aleados y tratados < 700N/mm²
Heat Treatable Steels <700N/mm²

9612021	Ø	P	L	I	d2	DIN	QTY	PCB	€
961202100180400	W1/8	40	56	11	3.5	371	1	1	16,08
961202100316240	W3/16	24	70	14	6	371	1	1	16,08
961202100140200	W1/4	20	80	16	7	371	1	1	18,24
961202100516180	W5/16	18	90	18	8	371	1	1	21,35
961202100380160	W3/8	16	90	18	9	371	1	1	23,62

MACHOS & COJINETES
CORE HOLE DRILLING

Ref.
302



MACHO DE MÁQUINA ACERO COBALTO 5% (HSSE) | BSW | AGUJERO PASANTE | APLICACIÓN: ACEROS SEMI-DUROS HASTA 700 N/mm²

COBALT STEEL 5% (HSSE) MACHINE TAP | BSW | THROUGH HOLE | APPLICATION: SEMI-HARD STEELS UP TO 700N/mm²

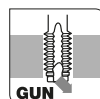
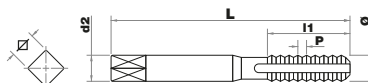

Aceros débilmente aleados <400 N/mm²
Low alloyed steels <400N/mm²



Aceros aleados y tratados < 700N/mm²
Heat Treatable Steels <700N/mm²

9613021	Ø	P	L	I	d2	DIN	QTY	PCB	€
961302100140200	W1/4	20	80	16	4.5	376	1	1	20,99
961302100380160	W3/8	16	90	18	7	376	1	1	27,17
961302100716140	W7/16	14	100	22	8	376	1	1	29,83
961302100120120	W1/2	12	110	25	9	376	1	1	31,21
961302100580110	W5/8	11	110	28	12	376	1	1	42,48
961302100340100	W3/4	10	125	32	14	376	1	1	54,35
961302110000080	W1"	8	160	36	20	376	1	1	92,42

Ref.
205



MACHO DE MÁQUINA ACERO COBALTO 5% (HSSE) | HELICOIDAL 35° | BSW | AGUJERO CIEGO | APLICACIÓN: ACEROS SEMI-DUROS HASTA 700 N/mm²

COBALT STEEL 5% (HSSE) MACHINE TAP | SPIRAL FLUTE 35° | BSW | BLIND HOLE | APPLICATION: SEMI-HARD STEELS UP TO 700N/mm²

MANGO • OVALADO • REFORZADO

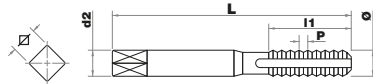

Aceros débilmente aleados <400 N/mm²
Low alloyed steels <400N/mm²



Aceros aleados y tratados < 700N/mm²
Heat Treatable Steels <700N/mm²

9612051	Ø	P	L	I	d2	DIN	QTY	PCB	€
961205100180400	W1/8	40	56	7	3.5	371	1	1	18,24
961205100316240	W3/16	24	70	10	6	371	1	1	18,24
961205100140200	W1/4	20	80	12	7	371	1	1	20,72
961205100516180	W5/16	18	90	12	8	371	1	1	24,15
961205100380160	W3/8	16	90	14	9	371	1	1	26,86

MACHOS & COJINETES
CORE HOLE DRILLING

Ref.
305



MACHO DE MÁQUINA ACERO COBALTO 5% (HSSE) | HELICOIDAL 35° | BSW | AGUJERO CIEGO | APLICACIÓN: ACEROS SEMI-DUROS HASTA 700 N/mm²

COBALT STEEL 5% (HSSE) MACHINE TAP | SPIRAL FLUTE 35° | BSW | BLIND HOLE | APPLICATION: SEMI-HARD STEELS UP TO 700N/mm²

MANGO • DELGADO

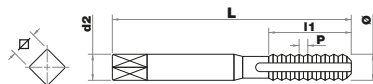

Aceros débilmente aleados <400 N/mm²
Low alloyed steels <400N/mm²



Aceros aleados y tratados < 700N/mm²
Heat Treatable Steels <700N/mm²

9613051	Ø	P	L	I	d2	DIN	QTY	PCB	€
961305100120120	W1/2	12	110	16	9	376	1	1	34,00
961305100580110	W5/8	11	110	20	12	376	1	1	45,64
961305100340100	W3/4	10	125	25	14	376	1	1	61,73
961305110000080	W1"	8	160	30	20	376	1	1	104,87

Ref.
301



**MACHO DE MÁQUINA ACERO COBALTO 5% (HSSE) | BSP GAS |
AGUJERO PASANTE/CIEGO | APLICACIÓN: ACEROS SEMI-DUROS
HASTA 700 N/mm²**

COBALT STEEL 5% (HSSE) MACHINE TAP | BSP GAS | THROUGH/BLIND HOLE |
APPLICATION: SEMI-HARD STEELS UP TO 700N/mm²

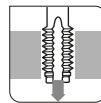
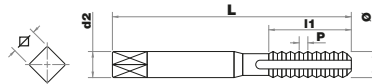

Aceros débilmente
aleados <400 N/mm²
Low alloyed
steels <400N/mm²



Aceros aleados y
tratados < 700N/mm²
Heat Treatable
Steels <700N/mm²

9633011	Ø	P	L	I	d2	DIN	QTY	PCB	€
963301100180280	G1/8	28	90	18	7	5156	1	1	23,64
963301100140190	G1/4	19	100	22	11	5156	1	1	35,03
963301100380190	G3/8	19	100	25	12	5156	1	1	41,93
963301100120140	G1/2	14	125	25	16	5156	1	1	53,01
963301100340140	G3/4	14	140	28	20	5156	1	1	82,96
963301110000110	G1"	11	160	36	25	5156	1	1	128,70
963301110140110	G1"1/4	11	170	40	32	5156	1	1	230,72

Ref.
302



**MACHO DE MÁQUINA ACERO COBALTO 5% (HSSE) | BSP GAS |
AGUJERO PASANTE | APLICACIÓN: ACEROS SEMI-DUROS HASTA
700 N/mm²**

COBALT STEEL 5% (HSSE) MACHINE TAP | BSP GAS | THROUGH HOLE |
APPLICATION: SEMI-HARD STEELS UP TO 700N/mm²

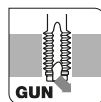
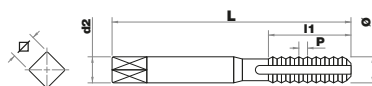

Aceros débilmente
aleados <400 N/mm²
Low alloyed
steels <400N/mm²



Aceros aleados y
tratados < 700N/mm²
Heat Treatable
Steels <700N/mm²

9633021	Ø	P	L	I	d2	DIN	QTY	PCB	€
963302100180280	G1/8	28	90	18	7	5156	1	1	28,76
963302100140190	G1/4	19	100	22	11	5156	1	1	38,54
963302100380190	G3/8	19	100	25	12	5156	1	1	46,11
963302100120140	G1/2	14	125	25	16	5156	1	1	58,30
963302100580140	G5/8	14	125	25	18	5156	1	1	72,43
963302100340140	G3/4	14	140	28	20	5156	1	1	91,27
963302110000110	G1"	11	160	36	25	5156	1	1	141,57

Ref.
305



MACHO DE MÁQUINA ACERO COBALTO 5% (HSSE) | HELICOIDAL 35°
| BSP GAS | AGUJERO CIEGO | APLICACIÓN: ACEROS SEMI-DUROS
HASTA 700 N/mm²

COBALT STEEL 5% (HSSE) MACHINE TAP | SPIRAL FLUTE 35° | BSP GAS |
 BLIND HOLE | APPLICATION: SEMI-HARD STEELS UP TO 700N/mm²

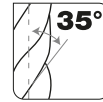
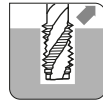
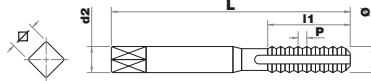

Aceros débilmente
aleados <400 N/mm²
Low alloyed
steels <400N/mm²



Aceros aleados y
tratados < 700N/mm²
Heat Treatable
Steels <700N/mm²

9633051	Ø	P	L	I	d2	DIN	QTY	PCB	€
963305100180280	G1/8	28	90	18	7	5156	1	1	30,63
963305100140190	G1/4	19	100	22	11	5156	1	1	44,01
963305100380190	G3/8	19	100	25	12	5156	1	1	52,50
963305100120140	G1/2	14	125	25	16	5156	1	1	66,23
963305100340140	G3/4	14	125	25	18	5156	1	1	103,67
963305110000110	G1"	14	140	28	20	5156	1	1	160,86
963305110140110	G1"1/4	11	160	36	25	5156	1	1	285,73
963305110120110	G1"1/2	11	190	32	36	5156	1	1	501,77

MACHOS & COJINETES
CORE HOLE DRILLING

Ref.
303



MACHO DE MÁQUINA ACERO COBALTO 5% (HSSE) | HELICOIDAL 15°
| BSP GAS | AGUJERO CIEGO | APLICACIÓN: ACEROS SEMI-DUROS
HASTA 700 N/mm²

COBALT STEEL 5% (HSSE) MACHINE TAP | SPIRAL FLUTE 15° | BSP GAS |
 APPLICATION: BLIND HOLE | SEMI-HARD STEELS UP TO 700N/mm²

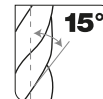
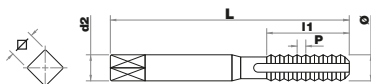

Aceros débilmente
aleados <400 N/mm²
Low alloyed
steels <400N/mm²



Aceros aleados y
tratados < 700N/mm²
Heat Treatable
Steels <700N/mm²

9633031	Ø	P	L	I	d2	DIN	QTY	PCB	€
963303100180280	G1/8	28	90	18	7	5156	1	1	30,63
963303100140190	G1/4	19	100	22	11	5156	1	1	44,01
963303100380190	G3/8	19	100	25	12	5156	1	1	52,50
963303100120140	G1/2	14	125	25	16	5156	1	1	66,23
963303100780140	G7/8	14	125	25	18	5156	1	1	139,43
963303100340140	G3/4	14	140	28	20	5156	1	1	103,67
963303110000110	G1"	11	160	36	25	5156	1	1	160,86

Ref.
310



**MACHO DE MÁQUINA HSS | NPT | AGUJERO PASANTE/CIEGO |
APLICACIÓN: ACEROS BLANDOS HASTA 400 N/mm²**

HSS MACHINE TAP | NPT | THROUGH/BLIND HOLE | APPLICATION: SOFT
STEELS UP TO 400 N/mm²

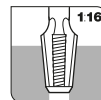
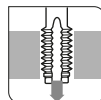
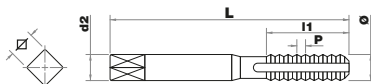

Aceros débilmente
aleados <400 N/mm²
Low alloyed
steels <400N/mm²

9643101	Ø	P	L	I	d2	QTY	PCB	€
964310100116270	NPT1/16	27	56	15	6	1	1	33,64
964310100180270	NPT1/8	27	70	15	8	1	1	33,64
964310100140180	NPT1/4	18	70	21	11	1	1	47,17
964310100380180	NPT3/8	18	75	21	14	1	1	64,54
964310100120140	NPT1/2	14	80	27	18	1	1	91,06
964310100340140	NPT3/4	14	90	27	22	1	1	139,20
964310110000115	NPT1"	11.5	110	33	25	1	1	156,45

Ref.
301



**MACHO DE MÁQUINA HSS | NPT | AGUJERO PASANTE/CIEGO |
APLICACIÓN: ACEROS BLANDOS HASTA 400 N/mm²**

HSS MACHINE TAP | SIM. DIN 5156 | NPT | THROUGH/BLIND HOLE |
APPLICATION: SOFT STEELS UP TO 400 N/mm²

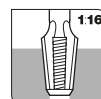
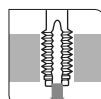
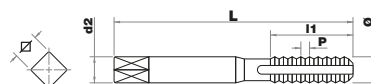

Aceros débilmente
aleados <400 N/mm²
Low alloyed
steels <400N/mm²

9643011	Ø	P	L	I	d2	QTY	PCB	€
964301100116270	NPT1/16	27	90	15	6	1	1	43,74
964301100180270	NPT1/8	27	90	15	8	1	1	43,74
964301100140180	NPT1/4	18	100	21	11	1	1	61,29
964301100380180	NPT3/8	18	110	21	14	1	1	84,70
964301100120140	NPT1/2	14	140	27	18	1	1	118,38
964301100340140	NPT3/4	14	140	27	22	1	1	181,01
964301110000115	NPT1"	11.5	160	33	25	1	1	203,37
964301110140115	NPT1"1/4	11.5	170	33	32	1	1	327,22

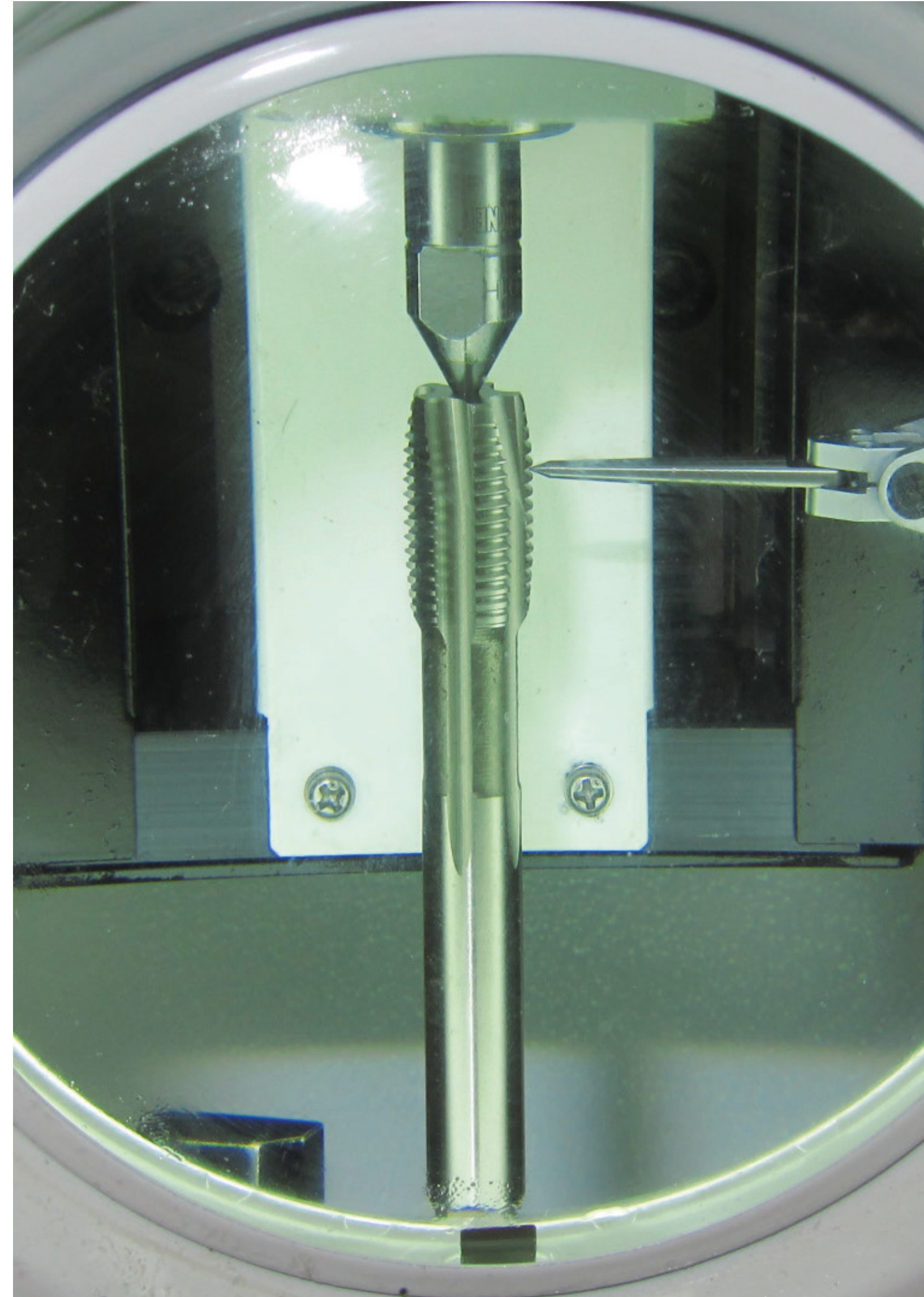



Polivalencia en los principales materiales utilizados:
Aceros de construcción, aceros para tratamiento térmico,
aceros inoxidable, chapas y perfiles de aluminio. ”

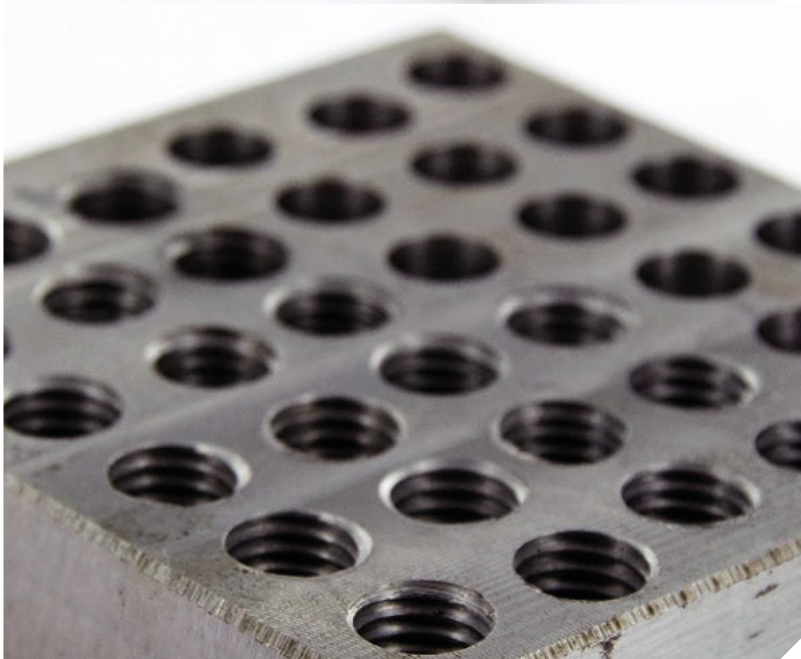

MACHOS MULTI- APLICACIÓN INNOVACIÓN Y RENDIMIENTO

Tivoly® ha diseñado geometrías especiales multi-aplicación: ángulos de corte específicos asociados a perfiles adecuados para evacuación junto con especialidades en conicidad inversa que garantizan roscados de alto rendimiento constantes en todo tipo de materiales:

- ▶ Reducción de rozamiento
- ▶ Mejor evacuación de la viruta
- ▶ Fácil extracción del macho
- ▶ Reducción de riesgos de recorte en la inversión y retroceso del macho.



- **MACHOS DE MANO MULTI-APLICACIÓN M-MF** **128**
MULTI-APPLICATIONS
HAND TAPS M-MF
- **MACHOS DE MANO MULTI-APLICACIÓN BSP GAS** **130**
MULTI-APPLICATIONS
HAND TAPS BSP GAS
- **MACHOS MÁQUINA MULTI-APLICACIÓN M-MF** **132**
MULTI-APPLICATIONS
MACHINE TAP M-MF
- **MACHOS MÁQUINA MULTI-APLICACIÓN BSP GAS** **138**
MULTI-APPLICATIONS
MACHINE TAP BSP GAS

Ref.
101



**JUEGO DE 3 MACHOS DE MANO MULTI-APLICACIÓN HSS
VAPORIZADO | MÉTRICO | AGUJERO PASANTE/CIEGO**

SET OF 3 MULTI-APPLICATION HAND TAPS HSS STEAM | METRIC | THROUGH/BLIND HOLE

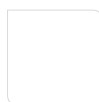
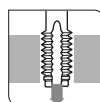
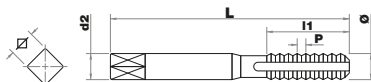
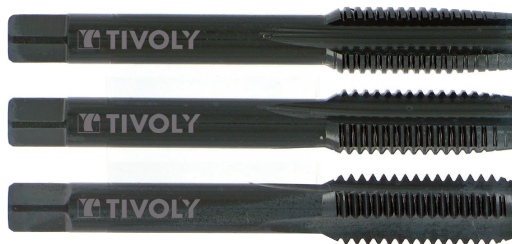

Aceros aleados
200-700 N/mm²
Alloyed steels
200-700N/mm²



Aceros aleados
y tratados
< 950N/mm²
Heat Treatable
Steels
<950N/mm²



Aceros
inoxidables
austeníticos
Austenitic
stainless
steels



Fundiciones
Cast iron



Aleaciones
de aluminio
Aluminium
alloys

9501011	Ø	P	L	I	d2	DIN	QTY	PCB	€
950101100200040	M2	0.4	36	11,5	2.8	352	1	1	38,24
950101100250045	M2,5	0.45	40	12	2.8	352	1	1	37,24
950101100300050	M3	0.5	40	11	3.5	352	1	1	22,81
950101100350060	M3,5	0.6	45	12	4	352	1	1	27,40
950101100400070	M4	0.7	45	12,5	4.5	352	1	1	22,81
950101100500080	M5	0.8	50	14,5	6	352	1	1	23,71
950101100600100	M6	1	50	15,5	6	352	1	1	23,71
950101100700100	M7	1	50	19	6	352	1	1	29,41
950101100800125	M8	1.25	56	22	6	352	1	1	27,54
950101100900125	M9	1.25	63	22	6	352	1	1	47,12
950101101000150	M10	1.5	70	24	7	352	1	1	35,45
950101101100150	M11	1.5	70	24	8	352	1	1	59,39
950101101200175	M12	1.75	75	29	9	352	1	1	50,77
950101101400200	M14	2	80	29	11	352	1	1	55,67
950101101600200	M16	2	80	31	12	352	1	1	76,23
950101101800250	M18	2.5	95	39	14	352	1	1	104,14
950101102000250	M20	2.5	95	39	16	352	1	1	115,61
950101102200250	M22	2.5	100	40	18	352	1	1	152,30
950101102400300	M24	3	110	45	18	352	1	1	178,90
950101102700300	M27	3	110	50	20	352	1	1	227,87
950101103000350	M30	3.5	125	56	22	352	1	1	291,29
950101103300350	M33	3.5	125	56	25	352	1	1	369,99
950101103600400	M36	4	150	63	28	352	1	1	472,55
950101103900400	M39	4	150	63	32	352	1	1	526,64
950101104200450	M42	4.5	150	63	32	352	1	1	662,16

MACHOS & COJINETES
CORE HOLE DRILLING

Ref.
102



**JUEGO DE 2 MACHOS DE MANO MULTI-APLICACIÓN HSS
VAPORIZADO | MÉTRICO FINO | AGUJERO PASANTE/CIEGO**

SET OF 2 MULTI-APPLICATION HAND TAPS HSS STEAM | METRIC FINE | THROUGH/BLIND HOLE

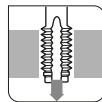
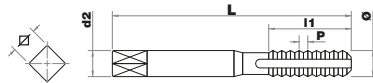

Aceros aleados
200-700 N/mm²
Alloyed steels
200-700N/mm²



Aceros aleados
y tratados
< 950N/mm²
Heat Treatable
Steels
<950N/mm²



Aceros
inoxidables
austeníticos
Austenitic
stainless
steels



Fundiciones
Cast iron



Aleaciones
de aluminio
Aluminium
alloys

9501021	Ø	P	L	I	d2	DIN	QTY	PCB	€
950102100500050	MF5	0.5	50	14,5	6	2181	1	1	41,51
950102100500075	MF5	0.75	50	15	6	2181	1	1	38,43
950102100600075	MF6	0.75	50	15,5	6	2181	1	1	25,09
950102100800075	MF8	0.75	50	22	6	2181	1	1	33,89
950102100800100	MF8	1	56	22	6	2181	1	1	25,07
950102101000100	MF10	1	63	18	7	2181	1	1	26,83
950102101000125	MF10	1.25	70	24	7	2181	1	1	27,17
950102101100100	MF11	1	63	20	8	2181	1	1	47,24
950102101100125	MF11	1.25	63	20	8	2181	1	1	47,24
950102101200100	MF12	1	70	20	9	2181	1	1	46,89
950102101200125	MF12	1.25	70	20	9	2181	1	1	46,98
950102101200150	MF12	1.5	70	20	9	2181	1	1	40,04
950102101400100	MF14	1	70	20	11	2181	1	1	65,19
950102101400125	MF14	1.25	70	20	11	2181	1	1	57,39
950102101400150	MF14	1.5	70	22	11	2181	1	1	44,63
950102101600100	MF16	1	70	22	12	2181	1	1	91,35
950102101600125	MF16	1.25	70	22	12	2181	1	1	96,09
950102101600150	MF16	1.5	70	22	12	2181	1	1	55,81
950102101800100	MF18	1	80	22	14	2181	1	1	101,50
950102101800125	MF18	1.25	80	22	14	2181	1	1	143,60
950102101800150	MF18	1.5	80	22	14	2181	1	1	73,82
950102101800200	MF18	2	80	22	14	2181	1	1	108,32
950102102000100	MF20	1	80	22	16	2181	1	1	134,52
950102102000150	MF20	1.5	80	22	16	2181	1	1	92,45
950102102000200	MF20	2	80	22	16	2181	1	1	112,82
950102102200150	MF22	1.5	80	22	18	2181	1	1	100,81
950102102200200	MF22	2	80	22	18	2181	1	1	150,74
950102102400150	MF24	1.5	90	22	18	2181	1	1	128,62
950102102400200	MF24	2	90	22	18	2181	1	1	168,57
950102102600150	MF26	1.5	90	22	20	2181	1	1	201,96
950102102700200	MF27	2	90	22	18	2181	1	1	233,63
950102103000150	MF30	1.5	90	22	22	2181	1	1	219,76
950102103000200	MF30	2	90	22	22	2181	1	1	253,32
950102103300200	MF33	2	100	25	25	2181	1	1	376,61

MACHOS & COJINETES
CORE HOLE DRILLING

Ref.
142



**JUEGO DE 2 MACHOS DE MANO MULTI-APLICACIÓN HSS
VAPORIZADO | BSP GAS | AGUJERO PASANTE/CIEGO**

SET OF 2 MULTI-APPLICATION HAND TAPS HSS STEAM | BSP GAS |
THROUGH/BLIND HOLE

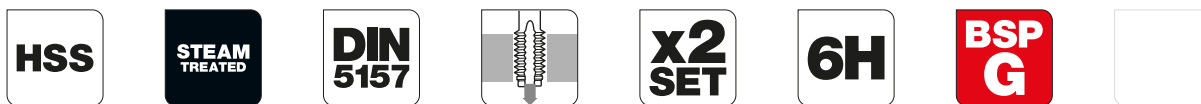
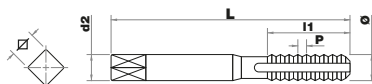

Aceros aleados
200-700 N/mm²
Alloyed steels
200-700N/mm²



Aceros aleados
y tratados
< 950N/mm²
Heat Treatable
Steels
<950N/mm²



Aceros
inoxidables
austeníticos
Austenitic
stainless
steels



Fundiciones
Cast iron



Aleaciones
de aluminio
Aluminium
alloys

9531421	Ø	P	L	I	d2	DIN	QTY	PCB	€
953142100180280	1/8	28	63	18	7	5157	1	1	31,60
953142100140190	1/4	19	70	20	11	5157	1	1	44,50
953142100380190	3/8	19	70	20	12	5157	1	1	55,90
953142100120140	1/2	14	80	22	16	5157	1	1	78,41
953142100580140	5/8	14	80	22	18	5157	1	1	100,36
953142100340140	3/4	14	90	22	20	5157	1	1	122,42
953142100780140	7/8	14	90	22	22	5157	1	1	163,25
953142110000110	1"	11	100	25	25	5157	1	1	194,09
953142110180110	1"1/8	11	125	32	28	5157	1	1	276,57
953142110140110	1"1/4	11	125	32	32	5157	1	1	304,38
953142110380110	1"3/8	11	125	32	36	5157	1	1	409,33
953142110120110	1"1/2	11	140	32	36	5157	1	1	460,01
953142120000110	2"	11	160	36	45	5157	1	1	839,38

MACHOS Y COJINETES DE ROSCAR
TAPPING & THREADING

- **MACHOS MÁQUINA
MULTI-APLICACIÓN
M-MF** **132**
MULTI-APPLICATION
MACHINE TAPS M-MF
- **MACHOS MÁQUINA
MULTI-APLICACIÓN
BSP GAS** **138**
MULTI-APPLICATION
MACHINE TAPS BSP GAS

Ref.
202



MACHO DE MÁQUINA MULTI-APLICACIÓN ACERO COBALTO 5% (HSSE) VAPORIZADO | MÉTRICO/MÉTRICO FINO | AGUJERO PASANTE
 COBALT 5% (HSSE) MULTI-APPLICATION MACHINE TAP | METRIC/METRIC FINE | THROUGH HOLE

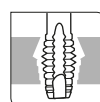
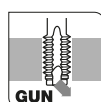
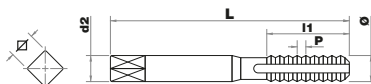

Aceros aleados
200-700 N/mm²
Alloyed steels
200-700N/mm²



Aceros aleados y tratados
< 950N/mm²
Heat Treatable
Steels
<950N/mm²



Aceros inoxidables
austeníticos
Austenitic
stainless
steels



Fundiciones
Cast iron



Aleaciones de aluminio
Aluminium
alloys

9602021	Ø	P	L	I	d2	DIN	QTY	PCB	€
960202100200040	M2	0.4	45	10	2.8	371	1	1	17,01
960202100250045	M2,5	0.45	50	10	2.8	371	1	1	17,01
960202100300050	M3	0.5	56	7	3.5	371	1	1	13,39
960202100350060	M3,5	0.6	56	8,4	4	371	1	1	15,62
960202100400070	M4	0.7	63	10	4.5	371	1	1	13,70
960202100500080	M5	0.8	70	11,2	6	371	1	1	13,70
960202100600100	M6	1	80	14	6	371	1	1	14,96
960202100700100	M7	1	80	14	7	371	1	1	18,52
960202100800125	M8	1.25	90	17,5	8	371	1	1	16,88
960202100900125	M9	1.25	90	17,5	8	371	1	1	24,44
960202101000150	M10	1.5	100	21	10	371	1	1	20,76

9602021	Ø	P	L	I	d2	DIN	QTY	PCB	€
960202100400050	MF4	0.5	63	10	4.5	371	1	1	24,54
960202100500050	MF5	0.5	70	11,2	6	371	1	1	25,24
960202100600075	MF6	0.75	80	14	6	371	1	1	20,40
960202100800075	MF8	0,75	90	17,5	8	371	1	1	20,40
960202100800100	MF8	1	90	17,5	8	371	1	1	20,51
960202101000100	MF10	1	90	21	10	371	1	1	22,90
960202101000125	MF10	1.25	100	21	10	371	1	1	27,28

MACHOS & COJINETES
CORE HOLE DRILLING



Ref.
302



**MACHO DE MÁQUINA MULTI-APLICACIÓN ACERO COBALTO 5%
(HSSE) VAPORIZADO | MÉTRICO | AGUJERO PASANTE**

COBALT 5% (HSSE) MULTI-APPLICATION MACHINE TAP | METRIC | THROUGH HOLE

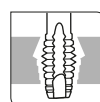
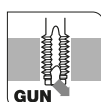
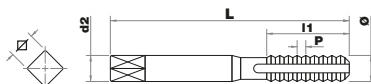

Aceros aleados
200-700 N/mm²
Alloyed steels
200-700N/mm²



Aceros aleados
y tratados
< 950N/mm²
Heat Treatable
Steels
<950N/mm²



Aceros
inoxidables
austeníticos
Austenitic
stainless
steels



Fundiciones
Cast iron



Aleaciones
de aluminio
Aluminium
alloys

9603021	Ø	P	L	I	d2	DIN	QTY	PCB	€
960302100300050	M3	0,5	56	10	2,7	376	1	1	13,90
960302100400070	M4	0,7	63	12	2,8	376	1	1	14,16
960302100500080	M5	0,8	70	13,5	3,5	376	1	1	14,16
960302100600100	M6	1	80	15,5	4,5	376	1	1	15,58
960302100800125	M8	1,25	90	17	6	376	1	1	17,76
960302101000150	M10	1,5	100	20	7	376	1	1	21,48
960302101200175	M12	1,75	110	22	9	376	1	1	26,52
960302101400200	M14	2	110	25	11	376	1	1	33,08
960302101600200	M16	2	110	28	12	376	1	1	38,73
960302101800250	M18	2,5	125	32	14	376	1	1	55,16
960302102000250	M20	2,5	140	32	16	376	1	1	59,60
960302102200250	M22	2,5	140	32	18	376	1	1	72,13
960302102400300	M24	3	160	32	18	376	1	1	85,91
960302102700300	M27	3	160	36	20	376	1	1	107,48
960302103000350	M30	3,5	180	40	22	376	1	1	138,11
960302103300350	M33	3,5	180	40	25	376	1	1	173,67
960302103600400	M36	4	200	45	28	376	1	1	212,21
960302103900400	M39	4	200	45	32	376	1	1	271,00
960302104200450	M42	4,5	200	50	32	376	1	1	348,35
960302104800500	M48	5	250	56	36	376	1	1	463,32

MACHOS & COJINETES
CORE HOLE DRILLING

Ref.
302



MACHO DE MÁQUINA MULTI-APLICACIÓN ACERO COBALTO 5% (HSSE) VAPORIZADO | MÉTRICO FINO | AGUJERO PASANTE

COBALT 5% (HSSE) MULTI-APPLICATION MACHINE TAP | METRIC FINE | THROUGH HOLE

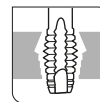
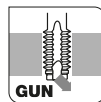
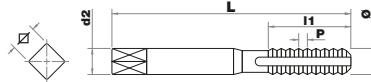

Aceros aleados
200-700 N/mm²
Alloyed steels
200-700N/mm²



Aceros aleados
y tratados
< 950N/mm²
Heat Treatable
Steels
<950N/mm²



Aceros
inoxidables
austeníticos
Austenitic
stainless
steels



Fundiciones
Cast iron



Aleaciones
de aluminio
Aluminium
alloys

9603021	Ø	P	L	I	d2	DIN	QTY	PCB	€
960302100800100	MF8	1	90	18	6	374	1	1	21,37
960302101000100	MF10	1	90	18	7	374	1	1	23,80
960302101000125	MF10	1.25	100	20	7	374	1	1	28,33
960302101100125	MF11	1.25	100	20	7	374	1	1	32,66
960302101200100	MF12	1	100	22	9	374	1	1	31,25
960302101200125	MF12	1.25	100	22	9	374	1	1	31,58
960302101200150	MF12	1.5	100	22	9	374	1	1	28,20
960302101400100	MF14	1	100	22	11	374	1	1	47,95
960302101400125	MF14	1.25	100	22	11	374	1	1	42,01
960302101400150	MF14	1.5	100	22	11	374	1	1	33,36
960302101500150	MF15	1.5	100	22	11	374	1	1	56,14
960302101600100	MF16	1	100	22	12	374	1	1	59,60
960302101600125	MF16	1.25	100	22	12	374	1	1	66,06
960302101600150	MF16	1.5	110	22	12	374	1	1	41,72
960302101800100	MF18	1	110	25	14	374	1	1	66,73
960302101800150	MF18	1.5	110	25	14	374	1	1	52,16
960302101800200	MF18	2	125	28	14	374	1	1	67,66
960302102000100	MF20	1	125	25	16	374	1	1	88,95
960302102000150	MF20	1.5	125	25	16	374	1	1	58,98
960302102000200	MF20	2	140	25	16	374	1	1	77,36
960302102200150	MF22	1.5	125	25	18	374	1	1	71,06
960302102200200	MF22	2	140	28	18	374	1	1	98,81
960302102400150	MF24	1.5	140	25	18	374	1	1	87,36
960302102400200	MF24	2	140	25	18	374	1	1	110,48
960302102500150	MF25	1.5	140	25	18	374	1	1	135,61
960302102600150	MF26	1.5	140	25	18	374	1	1	112,34
960302102700150	MF27	1.5	140	25	18	374	1	1	128,44
960302102800150	MF28	1.5	140	28	20	374	1	1	128,44
960302103000150	MF30	1.5	150	32	22	374	1	1	134,18
960302103000200	MF30	2	150	32	22	374	1	1	166,06
960302103200150	MF32	1.5	150	28	22	374	1	1	169,67
960302103600150	MF36	1.5	170	32	28	374	1	1	222,37
960302103600200	MF36	2	170	32	28	374	1	1	287,09
960302103600300	MF36	3	170	32	28	374	1	1	329,36

MACHOS & COJINETES
CORE HOLE DRILLING

Ref.
205



**MACHO DE MÁQUINA MULTI-APLICACIÓN ACERO COBALTO 5%
(HSSE) VAPORIZADO | HELICOIDAL 35° | METRICO/MÉTRICO FINO |
AGUJERO CIEGO**

COBALT 5% (HSSE) MULTI-APPLICATION MACHINE TAP | FLUTE 35° |
METRIC/METRIC FINE | BLIND HOLE

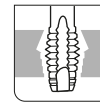
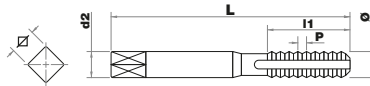

Aceros aleados
200-700 N/mm²
Alloyed steels
200-700N/mm²



Aceros
inoxidables
austeníticos
Austenitic
stainless
steels



Fundiciones
Cast iron



Aleaciones
de aluminio
Aluminium
alloys

9602051	Ø	P	L	I	d2	DIN	QTY	PCB	€
960205100200040	M2	0.4	45	10	2.8	371	1	1	19,58
960205100250045	M2,5	0,45	50	10	2,8	371	1	1	19,58
960205100300050	M3	0,5	50	7	3,5	371	1	1	15,79
960205100350060	M3,5	0,6	56	8,4	4	371	1	1	17,98
960205100400070	M4	0,7	63	10	4,5	371	1	1	15,80
960205100500080	M5	0,8	70	11,2	6	371	1	1	15,18
960205100600100	M6	1	80	14	6	371	1	1	16,67
960205100700100	M7	1	80	14	7	371	1	1	20,15
960205100800125	M8	1,25	90	17,5	8	371	1	1	19,85
960205100900125	M9	1,25	90	17,5	9	371	1	1	28,37
960205101000150	M10	1,50	100	21	10	371	1	1	23,59

9602051	Ø	P	L	I	d2	DIN	QTY	PCB	€
960205100800100	MF8	1	90	17,5	8	371	1	1	24,37
960205101000100	MF10	1	90	21	6	371	1	1	28,72
960205101000125	MF10	1,25	100	21	10	371	1	1	31,22

MACHOS & COJINETES
CORE HOLE DRILLING

Ref.
305



**MACHO DE MÁQUINA MULTI-APLICACIÓN ACERO COBALTO 5%
(HSSE) VAPORIZADO | HELICOIDAL 35° | METRICO/MÉTRICO FINO |
AGUJERO CIEGO**

COBALT 5% (HSSE) MULTI-APPLICATION MACHINE TAP | FLUTE 35° |
METRIC/METRIC FINE | BLIND HOLE

MANGO
DELGADO

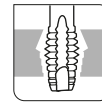
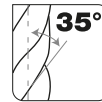
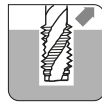
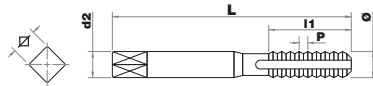

Aceros aleados
200-700 N/mm²
Alloyed steels
200-700N/mm²



Aceros
inoxidables
austeníticos
Austenitic
stainless
steels



Fundiciones
Cast iron



Aleaciones
de aluminio
Aluminium
alloys

9603051	Ø	P	L	I	d2	DIN	QTY	PCB	€
960305100400070	M4	0.7	63	7	2.8	376	1	1	16,35
960305100500080	M5	0,8	70	8,5	3,5	376	1	1	16,35
960305100600100	M6	1	80	9,5	3,5	376	1	1	17,17
960305100800125	M8	1,25	90	12	6	376	1	1	20,75
960305101000150	M10	1,5	100	14	7	376	1	1	24,26
960305101200175	M12	1,75	110	16	9	376	1	1	31,26
960305101400200	M14	2	110	18	11	376	1	1	38,15
960305101600200	M16	2	110	18	12	376	1	1	46,13
960305101800250	M18	2,5	125	25	14	376	1	1	62,09
960305102000250	M20	2,5	140	25	16	376	1	1	66,26
960305102200250	M22	2,5	140	25	18	376	1	1	81,46
960305102400300	M24	3	160	30	18	376	1	1	98,97
960305102700300	M27	3	160	30	20	376	1	1	121,82
960305103000350	M30	3,5	180	35	22	376	1	1	156,12
960305103300350	M33	3,5	180	40	25	376	1	1	195,41
960305103600400	M36	4	200	45	28	376	1	1	234,74

9603051	Ø	P	L	I	d2	DIN	QTY	PCB	€
960305100800100	MF8	1	90	12	6	374	1	1	25,07
960305101000100	MF10	1	90	12	7	374	1	1	29,55
960305101000125	MF10	1,25	100	14	7	374	1	1	32,18
960305101200100	MF12	1	100	14	9	374	1	1	36,72
960305101200125	MF12	1,25	100	14	9	374	1	1	35,19
960305101200150	MF12	1,5	100	14	9	374	1	1	33,84
960305101400100	MF14	1	100	16	11	374	1	1	56,70
960305101400125	MF14	1,25	100	16	11	374	1	1	51,97
960305101400150	MF14	1,5	100	18	11	374	1	1	41,56
960305101600150	MF16	1,5	110	18	12	374	1	1	51,08
960305101800150	MF18	1,5	110	18	14	374	1	1	61,71
960305102000150	MF20	1,5	125	18	16	374	1	1	70,51
960305102200150	MF22	1,5	125	18	18	374	1	1	73,59
960305102400150	MF24	1,5	140	18	18	374	1	1	103,40
960305103000150	MF30	1,5	150	22	22	374	1	1	158,97
960305103000200	MF30	2	150	22	22	374	1	1	295,19

MACHOS & COJINETES
CORE HOLE DRILLING

Ref.
342



**MACHO DE MÁQUINA MULTI-APLICACIÓN ACERO COBALTO 5%
(HSSE) VAPORIZADO | BSP GAS | AGUJERO PASANTE**

COBALT 5% (HSSE) MULTI-APPLICATION MACHINE TAP | BSP GAS |
THROUGH HOLE

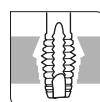
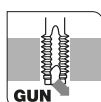
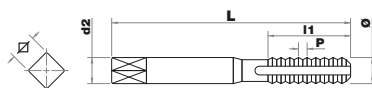

Aceros aleados
200-700 N/mm²
Alloyed steels
200-700N/mm²



Aceros
inoxidables
austeniticos
Austenitic
stainless
steels



Fundiciones
Cast iron



Aleaciones
de aluminio
Aluminium
alloys

9633421	Ø	P	L	I	d2	DIN	QTY	PCB	€
960202100200040	G1/8	28	90	18	7	5156	1	1	31,11
963342100140190	G1/4	19	100	22	11	5156	1	1	41,69
963342100380190	G3/8	19	100	25	12	5156	1	1	49,87
963342100120140	G1/2	14	125	25	16	5156	1	1	63,06
963342100580140	G5/8	14	125	25	18	5156	1	1	78,35
963342100340140	G3/4	14	140	28	20	5156	1	1	98,72
963342110000110	G1"	11	160	36	25	5156	1	1	153,12

Ref.
345



**MACHO DE MÁQUINA MULTI-APLICACIÓN ACERO COBALTO 5%
(HSSE) VAPORIZADO | HELICOIDAL 35° | BSP GAS | AGUJERO CIEGO**

COBALT 5% (HSSE) MULTI-APPLICATION MACHINE TAP | SPIRAL FLUTE 35° |
BSP GAS | BLIND HOLE

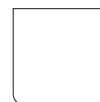
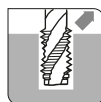
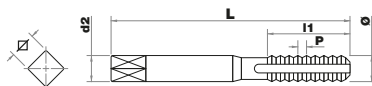

Aceros aleados
200-700 N/mm²
Alloyed steels
200-700N/mm²



Aceros
inoxidables
austeníticos
Austenitic
stainless
steels



Fundiciones
Cast iron



Aleaciones
de aluminio
Aluminium
alloys

9633451	Ø	P	L	I	d2	DIN	QTY	PCB	€
963345100180280	G1/8	28	90	18	7	5156	1	1	33,13
963345100140190	G1/4	19	100	22	11	5156	1	1	47,60
963345100380190	G3/8	19	100	25	12	5156	1	1	56,79
963345100120140	G1/2	14	125	25	16	5156	1	1	71,63
963345100340140	G3/4	14	125	25	18	5156	1	1	112,13
963345110000110	G1"	14	140	28	20	5156	1	1	173,98
963345110140110	G1"1/4	11	160	36	25	5156	1	1	309,05
963345110120110	G1"1/2	11	190	32	36	5156	1	1	542,72

MACHOS & COJINETES
CORE HOLE DRILLING

Ref.
582



MACHO DE MÁQUINA ACERO SINTERIZADO PULVIMETALÚRGICO (HSSEE) | MÉTRICO/MÉTRICO FINO | AGUJERO PASANTE | APLICACIÓN: ACEROS INOXIDABLES

MACHINE TAP (HSSEE) [ASP] | METRIC/METRIC FINE | THROUGH HOLE | APPLICATION: STAINLESS STEEL

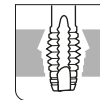
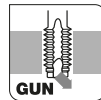
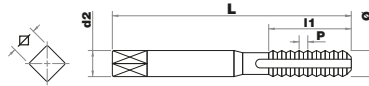

Aceros
inoxidables
ferríticos
Ferritic
stainless
steels



Aceros
inoxidables
martensíticos
Martensitic
stainless
steels



Aceros
inoxidables
austeníticos
Austenitic
stainless
steels

9605821	Ø	P	L	I	d2	DIN	QTY	PCB	€
960582100200040	M2	0,4	45	10	2,8	371	1	1	40,62
960582100250045	M2,5	0,45	50	10	2,8	371	1	1	41,93
960582100300050	M3	0,5	56	7	3,5	371	1	1	23,18
960582100350060	M3,5	0,6	56	8,4	4	371	1	1	26,56
960582100400070	M4	0,7	63	10	4,5	371	1	1	23,18
960582100500080	M5	0,8	70	11,2	6	371	1	1	24,26
960582100600100	M6	1	80	14	6	371	1	1	25,46
960582100800125	M8	1,25	90	17,5	8	371	1	1	29,41
960582101000150	M10	1,5	100	21	10	371	1	1	34,48

9605821	Ø	P	L	I	d2	DIN	QTY	PCB	€
960582100800100	MF8	1	90	17,5	8	371	1	1	33,84
960582101000100	MF10	1	90	21	10	371	1	1	38,90

MACHO DE MÁQUINA ACERO SINTERIZADO PULVIMETALÚRGICO (HSSEE) | MÉTRICO/MÉTRICO FINO | AGUJERO PASANTE | APLICACIÓN: ACEROS INOXIDABLES

MACHINE TAP (HSSEE) [ASP] | METRIC/METRIC FINE | THROUGH HOLE | APPLICATION: STAINLESS STEEL

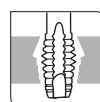
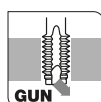
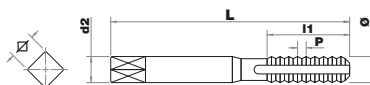

Aceros inoxidables ferríticos
Ferritic stainless steels



Aceros inoxidables martensíticos
Martensitic stainless steels



Aceros inoxidables austeníticos
Austenitic stainless steels

9606821	Ø	P	L	I	d2	DIN	QTY	PCB	€
960682100600100	M6	1	80	15,5	4,5	376	1	1	28,00
960682100800125	M8	1,25	90	17	6	376	1	1	32,36
960682101000150	M10	1,5	100	20	7	376	1	1	37,94
960682101200175	M12	1,75	110	22	9	376	1	1	46,72
960682101400200	M14	2	110	25	11	376	1	1	64,82
960682101600200	M16	2	110	28	12	376	1	1	69,89
960682101800250	M18	2,5	125	32	14	376	1	1	95,10
960682102000250	M20	2,5	140	32	16	376	1	1	102,72
960682102400300	M24	3	160	32	18	376	1	1	184,34

9606821	Ø	P	L	I	d2	DIN	QTY	PCB	€
960682100800100	MF8	1	90	18	6	374	1	1	38,88
960682101000100	MF10	1	90	18	7	374	1	1	44,73
960682101200150	MF12	1,5	100	22	9	374	1	1	53,73
960682101400150	MF14	1,5	100	22	11	374	1	1	74,53
960682101600150	MF16	1,5	110	22	12	374	1	1	80,39

MACHOS & COJINETES
CORE HOLE DRILLING



MACHO DE MÁQUINA ACERO SINTERIZADO PULVIMETALÚRGICO (HSSEE) | HELICOIDAL 35° | MÉTRICO/MÉTRICO FINO | AGUJERO CIEGO

MACHINE TAP (HSSEE) [ASP] | SPIRAL FLUTE 35° | METRIC/METRIC FINE | BLIND HOLE

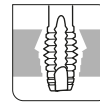
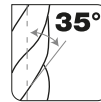
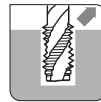
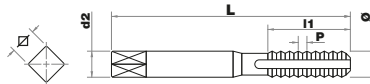

Aceros
inoxidables
ferríticos
Ferritic
stainless
steels



Aceros
inoxidables
martensíticos
Martensitic
stainless
steels



Aceros
inoxidables
austeníticos
Austenitic
stainless
steels

960585	Ø	P	L	I	d2	DIN	QTY	PCB	€
960585100300050	M3	0,5	50	7	3,5	371	1	1	25,46
960585100350060	M3,5	0,6	56	8,4	4	371	1	1	29,19
960585100400070	M4	0,7	63	10	4,5	371	1	1	25,46
960585100500080	M5	0,8	70	11,2	6	371	1	1	26,33
960585100600100	M6	1	80	14	6	371	1	1	26,56
960585100800125	M8	1,25	90	17,5	8	371	1	1	32,36
960585101000150	M10	1,5	100	21	10	371	1	1	39,44

960585	Ø	P	L	I	d2	DIN	QTY	PCB	€
960585100800100	MF8	1	90	17,5	8	371	1	1	38,32
960585101000100	MF10	1	90	21	6	371	1	1	44,73

MACHO DE MÁQUINA ACERO SINTERIZADO PULVIMETALÚRGICO
(HSSEE) | HELICOIDAL 35° | MÉTRICO/MÉTRICO FINO | AGUJERO CIEGO
 MACHINE TAP (HSSEE) [ASP] | SPIRAL FLUTE 35° | METRIC/METRIC FINE |
 BLIND HOLE

MANGO DELGADO

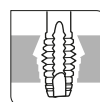
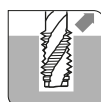
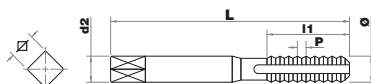

Aceros
inoxidables
ferríticos
Ferritic
stainless
steels



Aceros
inoxidables
martensíticos
Martensitic
stainless
steels



Aceros
inoxidables
austeníticos
Austenitic
stainless
steels

9606851	Ø	P	L	I	d2	DIN	QTY	PCB	€
960685100600100	M6	1	80	9,5	3,5	376	1	1	29,83
960685100800125	M8	1,25	90	12	6	376	1	1	35,53
960685101000150	M10	1,5	100	14	7	376	1	1	43,42
960685101200175	M12	1,75	110	16	9	376	1	1	55,46
960685101400200	M14	2	110	18	11	376	1	1	75,26
960685101600200	M16	2	110	18	12	376	1	1	83,29
960685101800250	M18	2,5	125	25	14	376	1	1	107,63
960685102000250	M20	2,5	140	25	16	376	1	1	114,99
960685102200250	M22	2,5	140	25	18	376	1	1	134,84
960685102400300	M24	3	160	30	18	376	1	1	137,23

9606851	Ø	P	L	I	d2	DIN	QTY	PCB	€
960685100800100	MF8	1	90	12	6	374	1	1	45,82
960685101000100	MF10	1	90	12	7	374	1	1	49,50
960685101200150	MF12	1,5	100	14	9	374	1	1	63,77
960685101400150	MF14	1,5	100	18	11	374	1	1	86,55
960685101600150	MF16	1,5	110	18	12	374	1	1	92,12
960685101800150	MF18	1,5	110	18	14	374	1	1	102,94

MACHOS & COJINETES
CORE HOLE DRILLING





MACHOS Y COJINETES DE ROSCAR
TAPPING & THREADING

CATÁLOGO GENERAL
2021

**FLASH-CUT
MACHOS DE MÁQUINA:**
FLASH-CUT MACHINE TAPS:

- **ACEROS** **146**
ST2 | ST5 | SRH
STEELS
ST2 | ST5 | SRH
- **INOX IT2 | IT5 | IRH** **151**
STAINLES IT2 | IT5 | IRH
- **ALUMINIO** **156**
AT2 | AT5 | GSH
ALUMINIUM
AT2 | AT5 | GSH
- **LATÓN BT1** **161**
BRASS BT1
- **FUNDICIÓN CT1** **164**
CAST IRON CT1

MACHOS & COJINETES
CORE HOLE DRILLING

Ref.
ST2



**MACHO DE MÁQUINA "FLASH CUT" ACERO COBALTO 5% (HSSE)
TIN | MÉTRICO/MÉTRICO FINO | AGUJERO PASANTE | APLICACIÓN:
ACEROS MUY DUROS HASTA 950 N/mm²**

COBALT 5% (HSSE) "FLASH CUT" MACHINE TAP TIN | METRIC/METRIC FINE | THROUGH HOLE | APPLICATION: VERY HARD STEELS UP TO 950 N/mm²

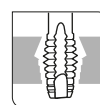
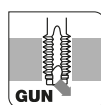
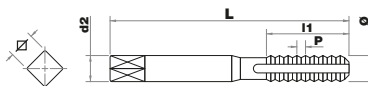

Aceros débilmente aleados <400 N/mm²
Low alloyed steels <400N/mm²



Aceros aleados y tratados <700N/mm²
Heat Treatable Steels <700N/mm²



Aceros aleados y tratados <950N/mm²
Heat Treatable Steels <950N/mm²

960ST21	Ø	P	L	I	d2	DIN	QTY	PCB	€
960ST2100300050	M3	0.5	56	10	3.5	371	1	1	16,50
960ST2100400070	M4	0.7	63	12	4.5	371	1	1	16,83
960ST2100500080	M5	0.8	70	14	6	371	1	1	16,83
960ST2100600100	M6	1	80	16	6	371	1	1	18,17
960ST2100800125	M8	1.25	90	18	8	371	1	1	20,86
960ST2101000150	M10	1.5	100	20	10	371	1	1	26,41
960ST2101200175	M12	1.75	110	22	9	376	1	1	34,05
960ST2101400200	M14	2	110	25	11	376	1	1	41,85
960ST2101600200	M16	2	110	28	12	376	1	1	48,59

960ST21	Ø	P	L	I	d3	DIN	QTY	PCB	€
960ST2100800100	MF8	1	90	18	8	371	1	1	23,38
960ST2101000100	MF10	1	90	18	10	371	1	1	29,58
960ST2101200150	MF12	1,5	100	22	9	374	1	1	36,44
960ST2101400150	MF14	1,5	100	22	11	374	1	1	44,81

MACHOS & COJINETES
CORE HOLE DRILLING

Ref.
ST5



**MACHO DE MÁQUINA "FLASH CUT" ACERO COBALTO 5% (HSSE)
TIN | HELICOIDAL 35° | MÉTRICO/MÉTRICO FINO | AGUJERO CIEGO |
APLICACIÓN: ACEROS MUY DUROS HASTA 950 N/mm²**

COBALT 5% (HSSE) "FLASH CUT" MACHINE TAP TIN | SPIRAL FLUTE 35° |
METRIC/METRIC FINE | BLIND HOLE | APPLICATION: VERY HARD STEELS UP
TO 950 N/mm²

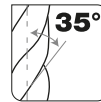
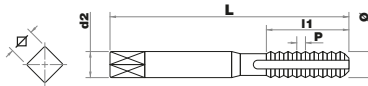
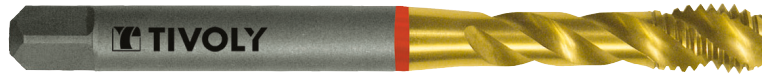

Aceros débilmente
aleados <400 N/mm²
Low alloyed
steels <400N/mm²



Aceros aleados y
tratados <700N/mm²
Heat Treatable
Steels <700N/mm²



Aceros aleados
y tratados
<950N/mm²
Heat Treatable
Steels
<950N/mm²

960ST51	Ø	P	L	I	d2	DIN	QTY	PCB	€
960ST5100300050	M3	0.5	56	5	3.5	371	1	1	19,04
960ST5100400070	M4	0.7	63	7	4.5	371	1	1	19,06
960ST5100500080	M5	0.8	70	9	6	371	1	1	18,37
960ST5100600100	M6	1	80	10	6	371	1	1	19,93
960ST5100800125	M8	1.25	90	12	8	371	1	1	23,97
960ST5101000150	M10	1.5	100	14	10	371	1	1	27,67
960ST5101200175	M12	1.75	110	16	9	376	1	1	39,42
960ST5101400200	M14	2	110	18	11	376	1	1	47,60
960ST5101600200	M16	2	110	18	12	376	1	1	56,99

960ST51	Ø	P	L	I	d2	DIN	QTY	PCB	€
960ST5100800100	MF8	1	90	12	8	371	1	1	26,87
960ST5101000100	MF10	1	90	14	10	371	1	1	31,00
960ST5101200150	MF12	1.5	100	14	9	374	1	1	42,23
960ST5101400150	MF14	1.5	100	18	11	374	1	1	51,00

MACHOS & COJINETES
CORE HOLE DRILLING

Ref.
SRH



MACHO DE MÁQUINA LAMINACIÓN "FLASH CUT" ACERO SINTERIZADO PULVIMETALÚRGICO (HSSE) TIN | MÉTRICO/MÉTRICO FINO | APLICACIÓN: ACEROS MUY DUROS HASTA 1400 N/mm²

FORMING MACHINE TAP "FLASH CUT" [ASP] TIN | METRIC/METRIC FINE |

APPLICATION: VERY HARD STEELS UP TO 1400 N/mm²

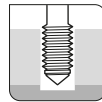
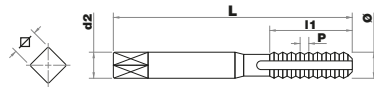

Aceros débilmente aleados <400 N/mm²
Low alloyed steels <400N/mm²



Aceros aleados y tratados < 700N/mm²
Heat Treatable Steels <700N/mm²



Aceros aleados y tratados 700-1400 N/mm²
Heat treatables steels 700-1400N/mm²

960SRH1	Ø	P	L	I	d2	DIN	QTY	PCB	€
960SRH100300050	M3	0,5	56	10	3,5	371	1	1	42,44
960SRH100400070	M4	0,7	63	12	4,5	371	1	1	43,50
960SRH100500080	M5	0,8	70	14	6	371	1	1	43,50
960SRH100600100	M6	1	80	16	6	371	1	1	46,53
960SRH100800125	M8	1,25	90	18	8	371	1	1	58,66
960SRH101000150	M10	1,5	100	20	10	371	1	1	67,24
960SRH101200175	M12	1,75	110	22	9	376	1	1	75,53
960SRH101400200	M14	2	110	25	11	376	1	1	98,60
960SRH101600200	M16	2	110	28	12	376	1	1	109,11

960SRH1	Ø	P	L	I	d2	DIN	QTY	PCB	€
960SRH100800100	MF8	1	90	18	8	371	1	1	65,69
960SRH101000100	MF10	1	90	18	10	371	1	1	75,33
960SRH101200150	MF12	1,5	100	22	9	374	1	1	86,85
960SRH101400150	MF14	1,5	100	22	11	374	1	1	113,36

MACHOS & COJINETES
CORE HOLE DRILLING

Ref.
ST2



MACHO DE MÁQUINA "FLASH CUT" ACERO COBALTO 5% (HSSE) | TIN | UNC/UNF | AGUJERO PASANTE | APLICACIÓN: ACEROS MUY DUROS HASTA 950 N/mm²

COBALT 5% (HSSE) "FLASH CUT" MACHINE TAP TIN | UNC/UNF | THROUGH HOLE | APPLICATION: VERY HARD STEELS UP TO 950 N/mm²

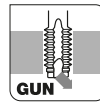
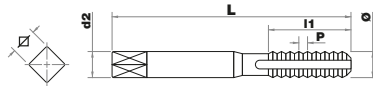
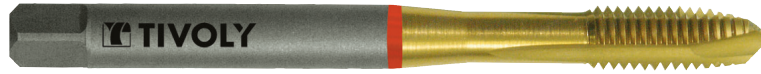

Aceros débilmente aleados <400 N/mm²
Low alloyed steels <400N/mm²



Aceros aleados y tratados <700N/mm²
Heat Treatable Steels <700N/mm²



Aceros aleados y tratados <950N/mm²
Heat Treatable Steels <950N/mm²

962ST21	Ø	P	L	I	d2	DIN	QTY	PCB	€
962ST2100140200	UNC1/4	20	80	16	7	371	1	1	28,65
962ST2100380160	UNC3/8	16	90	18	9	371	1	1	41,34
962ST2100120130	UNC1/2	13	110	25	9	376	1	1	51,73
962ST2100340100	UNC3/4	10	125	32	14	376	1	1	91,58
962ST2110000080	UNC1"	8	160	36	20	376	1	1	149,40

962ST21	Ø	P	L	I	d2	DIN	QTY	PCB	€
962ST2100140280	UNF1/4	28	80	16	7	371	1	1	29,89
962ST2100380240	UNF3/8	24	100	18	9	371	1	1	44,58
962ST2100120200	UNF1/2	20	110	25	9	376	1	1	58,51
962ST2100340160	UNF3/4	16	125	32	14	376	1	1	102,64
962ST2110000120	UNF1"	12	140	32	20	376	1	1	177,29

MACHOS & COJINETES
CORE HOLE DRILLING

Ref.
ST5



**MACHO DE MÁQUINA "FLASH CUT" ACERO COBALTO 5% (HSSE) TIN
| HELICOIDAL 35° | UNC/UNF | AGUJERO CIEGO | APLICACIÓN:
ACEROS MUY DUROS HASTA 950 N/mm²**

COBALT 5% (HSSE) "FLASH CUT" MACHINE TAP TIN | SPIRAL FLUTE 35° |
UNC/UNF | BLIND HOLE | APPLICATION: VERY HARD STEELS UP TO 950 N/mm²

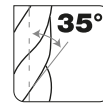
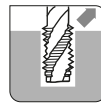
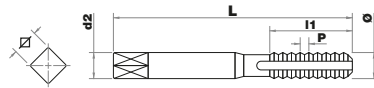

Aceros débilmente aleados <400 N/mm²
Low alloyed steels <400N/mm²



Aceros aleados y tratados <700N/mm²
Heat Treatable Steels <700N/mm²



Aceros aleados y tratados <950N/mm²
Heat Treatable Steels <950N/mm²

962ST51	Ø	P	L	I	d2	DIN	QTY	PCB	€
962ST5100140200	UNC1/4	20	80	12	7	371	1	1	34,47
962ST5100380160	UNC3/8	16	90	14	9	371	1	1	46,94
962ST5100120130	UNC1/2	13	110	16	9	376	1	1	58,76
962ST5100340100	UNC3/4	10	125	25	14	376	1	1	104,04
962ST5110000080	UNC1"	8	160	30	20	376	1	1	193,88

962ST51	Ø	P	L	I	d2	DIN	QTY	PCB	€
962ST5100140280	UNF1/4	28	80	10	7	371	1	1	35,02
962ST5100380240	UNF3/8	24	100	14	9	371	1	1	50,05
962ST5100120200	UNF1/2	20	110	16	9	376	1	1	66,77
962ST5100340160	UNF3/4	16	125	18	14	376	1	1	116,74
962ST5110000120	UNF1"	12	140	25	20	376	1	1	229,17

Ref.
IT2



**MACHO DE MÁQUINA "FLASH CUT" ACERO SINTERIZADO
PULVIMETALURGICO (HSSEE) TICN | MÉTRICO/MÉTRICO FINO |
AGUJERO PASANTE | APLICACIÓN: ACEROS MUY DUROS HASTA
1400 N/mm², ACEROS INOXIDABLES**

"FLASH CUT" MACHINE TAP HSSEE [ASP] TICN | METRIC/METRIC FINE |
THROUGH HOLE | APPLICATION: VERY HARD STEELS UP TO 1400 N/mm²,
STAINLESS STEELS

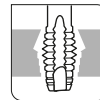
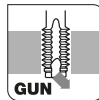
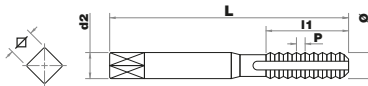

Aceros aleados
y tratados
700-1400 N/mm²
Heat treatables steels
700-1400N/mm²



Aceros
inoxidables
Stainless
Steel



Aleaciones
refractarias Co
/ Ni y Titanio
Ni / Co based
special alloys &
Titanium

960IT21	Ø	P	L	I	d2	DIN	QTY	PCB	€
960IT2100300050	M3	0.5	56	10	3.5	371	1	1	27,24
960IT2100400070	M4	0.7	63	12	4.5	371	1	1	27,16
960IT2100500080	M5	0.8	70	14	6	371	1	1	28,57
960IT2100600100	M6	1	80	16	6	371	1	1	29,81
960IT2100800125	M8	1.25	90	18	8	371	1	1	34,96
960IT2101000150	M10	1.5	100	20	10	371	1	1	42,13
960IT2101200175	M12	1.75	110	22	9	376	1	1	58,59
960IT2101400200	M14	2	110	25	11	376	1	1	80,65
960IT2101600200	M16	2	110	28	12	376	1	1	87,13

960IT21	Ø	P	L	I	d2	DIN	QTY	PCB	€
960IT2100800100	MF8	1	90	18	8	371	1	1	40,54
960IT2101000100	MF10	1	90	18	10	371	1	1	45,11
960IT2101200150	MF12	1.5	100	22	9	374	1	1	65,16
960IT2101400150	MF14	1.5	100	22	11	374	1	1	87,45

MACHOS & COJINETES
CORE HOLE DRILLING

Ref.
IT5



**MACHO DE MÁQUINA "FLASH CUT" ACERO SINTERIZADO
PULVIMETALÚRGICO (HSSEE) TICN | HELICOIDAL 35° |
MÉTRICO/MÉTRICO FINO | AGUJERO CIEGO | APLICACIÓN: ACEROS
MUY DUROS HASTA 1400 N/mm², ACEROS INOXIDABLES**

"FLASH CUT" MACHINE TAP HSSEE [ASP] TICN | SPIRAL FLUTE 35° | METRIC/
METRIC FINE | BLIND HOLE | APPLICATION: VERY HARD STEELS UP TO 1400 N/mm²,
STAINLESS STEELS

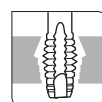
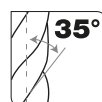
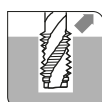
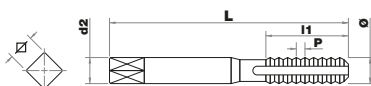

Aceros aleados
y tratados
700-1400 N/mm²
Heat treatables steels
700-1400N/mm²



Aceros
inoxidables
Stainless
Steel



Aleaciones
refractarias Co
/ Ni y Titanio
Ni / Co based
special alloys &
Titanium

960IT51	Ø	P	L	I	d2	DIN	QTY	PCB	€
960IT5100300050	M3	0.5	56	5	3.5	371	1	1	28,35
960IT5100400070	M4	0.7	63	7	4.5	371	1	1	28,35
960IT5100500080	M5	0.8	70	9	6	371	1	1	29,13
960IT5100600100	M6	1	80	10	6	371	1	1	29,91
960IT5100800125	M8	1.25	90	12	8	371	1	1	36,17
960IT5101000150	M10	1.5	100	14	10	371	1	1	45,44
960IT5101200175	M12	1.75	110	16	9	376	1	1	63,27
960IT5101400200	M14	2	110	18	11	376	1	1	83,37
960IT5101600200	M16	2	110	18	12	376	1	1	93,02

960IT51	Ø	P	L	I	d2	DIN	QTY	PCB	€
960IT5100800100	MF8	1	90	12	8	371	1	1	39,96
960IT5101000100	MF10	1	90	14	10	371	1	1	51,07
960IT5101200150	MF12	1.5	100	14	9	374	1	1	68,20
960IT5101400150	MF14	1.5	100	18	11	374	1	1	93,46

MACHOS & COJINETES
CORE HOLE DRILLING

Ref.
IRH



MACHO DE MÁQUINA LAMINACIÓN "FLASH CUT" ACERO SINTERIZADO PULVIMETALÚRGICO (HSSEE) TICN | MÉTRICO/MÉTRICO FINO | APLICACIÓN: ACEROS MUY DUROS HASTA 1400 N/mm², ACEROS INOXIDABLES

FORMING MACHINE TAP [ASP] TICN | METRIC/METRIC FINE | APPLICATION: VERY HARD STEELS UP TO 1400 N/mm², STAINLESS STEELS

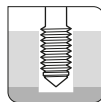
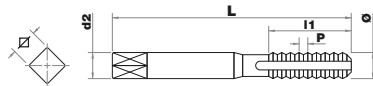

Aceros aleados y tratados
700-1400 N/mm²
Heat treatables steels
700-1400N/mm²



Aceros inoxidables
Stainless Steel



Aleaciones refractarias
Co / Ni
Ni / Co based special alloys

960IRH1	Ø	P	L	I	d2	DIN	QTY	PCB	€
960IRH100300050	M3	0,5	56	10	3,5	371	1	1	43,71
960IRH100400070	M4	0,7	63	12	4,5	371	1	1	44,82
960IRH100500080	M5	0,8	70	14	6	371	1	1	44,82
960IRH100600100	M6	1	80	16	6	371	1	1	47,92
960IRH100800125	M8	1,25	90	18	8	371	1	1	60,42
960IRH101000150	M10	1,5	100	20	10	371	1	1	69,27
960IRH101200175	M12	1,75	110	22	9	376	1	1	81,62
960IRH101400200	M14	2	110	25	11	376	1	1	102,50
960IRH101600200	M16	2	110	28	12	376	1	1	113,63

960IRH1	Ø	P	L	I	d2	DIN	QTY	PCB	€
960IRH100800100	MF8	1	90	18	8	371	1	1	69,77
960IRH101000100	MF10	1	90	18	10	371	1	1	79,68
960IRH101200150	MF12	1,5	100	22	9	374	1	1	106,08
960IRH101400150	MF14	1,5	100	22	11	374	1	1	141,81

MACHOS & COJINETES
CORE HOLE DRILLING

Ref.
IT2



**MACHO DE MÁQUINA "FLASH CUT" ACERO SINTERIZADO
PULVIMETALÚRGICO (HSSEE) TICN | UNC/UNF | AGUJERO PASANTE |
APLICACIÓN: ACEROS MUY DUROS HASTA 1400N/mm², ACEROS
INOXIDABLES**

"FLASH CUT" MACHINE TAP HSSEE [ASP] TICN | UNC/UNF | THROUGH HOLE |
APPLICATION: VERY HARD STEELS UP TO 1400 N/mm², STAINLESS STEELS

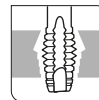
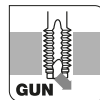
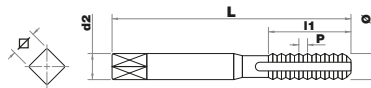

Aceros aleados y tratados
700-1400 N/mm²
Heat treatables steels
700-1400N/mm²



Aceros
inoxidables
Stainless
Steel



Aleaciones refractarias Co / Ni y Titanio
Ni / Co based special alloys & Titanium

962IT21	Ø	P	L	I	d2	DIN	QTY	PCB	€
962IT2100140200	UNC1/4	20	80	16	7	371	1	1	48,27
962IT2100380160	UNC3/8	16	90	18	9	371	1	1	88,18
962IT2100120130	UNC1/2	13	110	25	9	376	1	1	69,99
962IT2100340100	UNC3/4	10	125	32	14	376	1	1	157,46
962IT2110000080	UNC1"	8	160	36	20	376	1	1	257,91

962IT21	Ø	P	L	I	d2	DIN	QTY	PCB	€
962IT2100140280	UNF1/4	28	80	16	7	371	1	1	50,42
962IT2100380240	UNF3/8	24	100	18	9	371	1	1	99,95
962IT2100120200	UNF1/2	20	110	25	9	376	1	1	75,84
962IT2100340160	UNF3/4	16	125	32	14	376	1	1	176,60
962IT2110000120	UNF1"	12	140	32	20	376	1	1	304,33

MACHOS & COJINETES
CORE HOLE DRILLING

Ref.
IT5



**MACHO DE MÁQUINA "FLASH CUT" ACERO SINTERIZADO
PULVIMETALÚRGICO (HSSEE) TICN || HELICOIDAL 35° | UNC/UNF |
AGUJERO CIEGO | APLICACIÓN: ACEROS MUY DUROS HASTA
1400N/mm², ACEROS INOXIDABLES**

"FLASH CUT" MACHINE TAP HSSEE [ASP] TICN | SPIRAL FLUTE 35° | UNC/UNF | BLIND
HOLE | APPLICATION: VERY HARD STEELS UP TO 1400 N/mm², STAINLESS STEELS

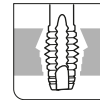
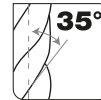
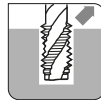
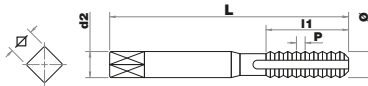

Aceros aleados
y tratados
700-1400 N/mm²
Heat treatables steels
700-1400N/mm²



Aceros
inoxidables
Stainless
Steel



Aleaciones
refractarias Co
/ Ni y Titanio
Ni / Co based
special alloys &
Titanium

962IT51	Ø	P	L	I	d2	DIN	QTY	PCB	€
962IT5100140200	UNC1/4	20	80	12	7	371	1	1	54,91
962IT5100380160	UNC3/8	16	90	14	9	371	1	1	100,53
962IT5100120130	UNC1/2	13	110	16	9	376	1	1	80,04
962IT5100340100	UNC3/4	10	125	25	14	376	1	1	179,16
962IT5110000080	UNC1"	8	160	30	20	376	1	1	335,18

962IT51	Ø	P	L	I	d2	DIN	QTY	PCB	€
962IT5100140280	UNF1/4	28	80	10	7	371	1	1	58,36
962IT5100380240	UNF3/8	24	100	14	9	371	1	1	114,43
962IT5100120200	UNF1/2	20	110	16	9	376	1	1	85,41
962IT5100340160	UNF3/4	16	125	18	14	376	1	1	201,05
962IT5110000120	UNF1"	12	140	25	20	376	1	1	396,62

MACHOS & COJINETES
CORE HOLE DRILLING

Ref.
AT2



**MACHO DE MÁQUINA "FLASH CUT" ACERO SINTERIZADO
PULVIMETALURGICO (HSSEE) TIN | DIENTE ALTERNO | MÉTRICO/
MÉTRICO FINO | AGUJERO PASANTE | APLICACIÓN: ALUMINIO**

"FLASH CUT" MACHINE TAP HSSEE [ASP] TIN | INTERRUPTED THREADS |
METRIC/METRIC FINE | THROUGH HOLE | APPLICATION: ALUMINIUM

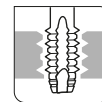
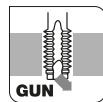
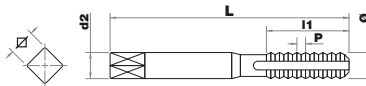

Aleaciones de aluminio dúctil
Fat aluminium alloys



Aleaciones de aluminio Si<10%
Aluminium alloys Si<10%



Aleaciones de aluminio Si>10%
Aluminium alloys Si>10%

960AT21	Ø	P	L	I	d2	DIN	QTY	PCB	€
960AT2100300050	M3	0.5	56	10	3.5	371	1	1	28,81
960AT2100400070	M4	0.7	63	12	4.5	371	1	1	28,81
960AT2100500080	M5	0.8	70	14	6	371	1	1	30,07
960AT2100600100	M6	1	80	16	6	371	1	1	31,36
960AT2100800125	M8	1.25	90	18	8	371	1	1	36,58
960AT2101000150	M10	1.5	100	20	10	371	1	1	43,79
960AT2101200175	M12	1.75	110	22	9	376	1	1	60,46
960AT2101400200	M14	2	110	28	11	376	1	1	82,56
960AT2101600200	M16	2	110	28	12	376	1	1	89,17

960AT21	Ø	P	L	I	d2	DIN	QTY	PCB	€
960AT2100800100	MF8	1	90	18	8	371	1	1	42,13
960AT2101000100	MF10	1	90	18	10	371	1	1	46,75
960AT2101200150	MF12	1.5	100	22	9	374	1	1	66,90
960AT2101400150	MF14	1.5	100	22	11	374	1	1	89,28

MACHOS & COJINETES
CORE HOLE DRILLING

Ref.
AT5



**MACHO DE MÁQUINA "FLASH CUT" ACERO SINTERIZADO
PULVIMETALÚRGICO (HSSEE) TIN || HELICOIDAL 35° | DIENTE ALTERNO
| MÉTRICO/MÉTRICO FINO | AGUJERO CIEGO | APLICACIÓN: ALUMINIO**

"FLASH CUT" MACHINE TAP HSSEE [ASP] TIN | SPIRAL FLUTE 35° | INTERRUPTED
THREADS | METRIC/METRIC FINE | BLIND HOLE | APPLICATION: ALUMINIUM

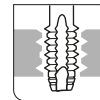
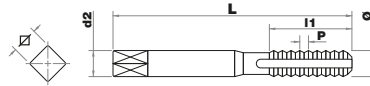
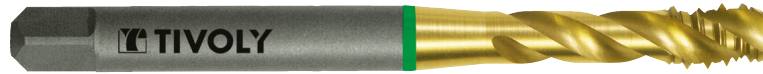

Aleaciones de aluminio dúctil
Fat aluminium alloys



Aleaciones de aluminio Si<10%
Aluminium alloys Si<10%



Aleaciones de aluminio Si>10%
Aluminium alloys Si>10%

960AT51	Ø	P	L	I	d2	DIN	QTY	PCB	€
960AT5100300050	M3	0.5	56	5	3.5	371	1	1	29,70
960AT5100400070	M4	0.7	63	7	4.5	371	1	1	29,70
960AT5100500080	M5	0.8	70	9	6	371	1	1	30,65
960AT5100600100	M6	1	80	10	6	371	1	1	31,49
960AT5100800125	M8	1.25	90	12	8	371	1	1	37,79
960AT5101000150	M10	1.5	100	14	10	371	1	1	47,12
960AT5101200175	M12	1.75	110	16	9	376	1	1	64,99
960AT5101400200	M14	2	110	18	11	376	1	1	85,10
960AT5101600200	M16	2	110	18	12	376	1	1	94,87

960AT51	Ø	P	L	I	d2	DIN	QTY	PCB	€
960AT5100800100	MF8	1	90	12	8	371	1	1	41,57
960AT5101000100	MF10	1	90	14	10	371	1	1	52,74
960AT5101200150	MF12	1.5	100	14	9	374	1	1	70,08
960AT5101400150	MF14	1.5	100	18	11	374	1	1	95,32

MACHOS & COJINETES
CORE HOLE DRILLING

Ref.
GSH



MACHO DE MÁQUINA LAMINACIÓN "FLASH CUT" ACERO SINTERIZADO PULVIMETALÚRGICO (HSSEE) TIN | MÉTRICO/MÉTRICO FINO | APLICACIÓN: ALUMINIO

FORMING MACHINE TAP "FLASH CUT" HSSEE [ASP] TIN | METRIC/METRIC FINE | APPLICATION: ALUMINIUM

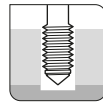
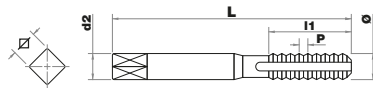

Aleaciones de aluminio dúctil
Fat aluminium alloys



Aleaciones de aluminio Si<10%
Aluminium alloys Si<10%



Aleaciones de aluminio Si>10%
Aluminium alloys Si>10%

960GSH1	Ø	P	L	I	d2	DIN	QTY	PCB	€
960GSH100300050	M3	0,5	56	10	3,5	371	1	1	33,91
960GSH100400070	M4	0,7	63	12	4,5	371	1	1	34,98
960GSH100500080	M5	0,8	70	14	6	371	1	1	34,98
960GSH100600100	M6	1	80	16	6	371	1	1	37,33
960GSH100800125	M8	1,25	90	18	8	371	1	1	47,92
960GSH101000150	M10	1,5	100	20	10	371	1	1	54,72
960GSH101200175	M12	1,75	110	22	9	376	1	1	70,95
960GSH101400200	M14	2	110	25	11	376	1	1	94,89
960GSH101600200	M16	2	110	28	12	376	1	1	105,31

960GSH1	Ø	P	L	I	d2	DIN	QTY	PCB	€
960GSH100800100	MF8	1	90	18	8	371	1	1	53,66
960GSH101000100	MF10	1	90	18	10	371	1	1	61,29
960GSH101200150	MF12	1,5	100	22	9	374	1	1	81,59
960GSH101400150	MF14	1,5	100	22	11	374	1	1	109,06

MACHOS & COJINETES
CORE HOLE DRILLING

Ref.
AT2



**MACHO DE MÁQUINA "FLASH CUT" ACERO SINTERIZADO
PULVIMETALÚRGICO (HSSEE) TIN | DIENTE ALTERNO | UNC/UNF |
AGUJERO PASANTE | APLICACIÓN: ALUMINIO**

"FLASH CUT" MACHINE TAP HSSEE [ASP] TIN | SPIRAL FLUTE 35° | INTERRUPTED THREADS | UNC/UNF | THROUGH HOLE | APPLICATION: ALUMINIUM

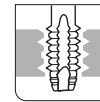
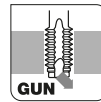
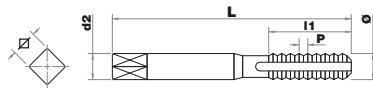

Aleaciones de aluminio dúctil
Fat aluminium alloys



Aleaciones de aluminio Si<10%
Aluminium alloys Si<10%



Aleaciones de aluminio Si>10%
Aluminium alloys Si>10%

962AT21	Ø	P	L	I	d2	DIN	QTY	PCB	€
962AT2100140200	UNC1/4	20	80	16	7	371	1	1	49,84
962AT2100380160	UNC3/8	16	90	18	9	371	1	1	71,89
962AT2100120130	UNC1/2	13	110	25	9	376	1	1	89,99
962AT2100340100	UNC3/4	10	125	32	14	376	1	1	159,29
962AT2110000080	UNC1"	8	160	36	20	376	1	1	259,80

962AT21	Ø	P	L	I	d2	DIN	QTY	PCB	€
962AT2100140280	UNF1/4	28	80	16	7	371	1	1	51,96
962AT2100380240	UNF3/8	24	100	18	9	371	1	1	77,54
962AT2100120200	UNF1/2	20	110	25	9	376	1	1	101,71
962AT2100340160	UNF3/4	16	125	32	14	376	1	1	178,48
962AT2110000120	UNF1"	12	140	32	20	376	1	1	308,36

MACHOS & COJINETES
CORE HOLE DRILLING

Ref.
AT5



**MACHO DE MÁQUINA "FLASH CUT" ACERO SINTERIZADO
PULVIMETALÚRGICO (HSSEE) TIN | HELICOIDAL 35° | DIENTE ALTERNO
| UNC/UNF | AGUJERO CIEGO | APLICACIÓN: ALUMINIO**

"FLASH CUT" MACHINE TAP HSSEE [ASP] TIN | SPIRAL FLUTE 35° | INTERRUPTED
THREADS | UNC/UNF | BLIND HOLE | APPLICATION: ALUMINIUM

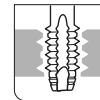
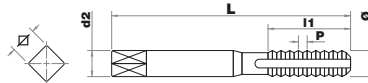
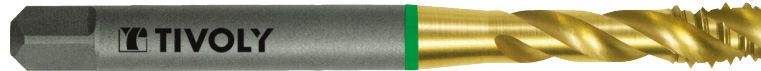

Aleaciones de aluminio dúctil
Fat aluminium alloys



Aleaciones de aluminio Si<10%
Aluminium alloys Si<10%



Aleaciones de aluminio Si>10%
Aluminium alloys Si>10%

962AT51	Ø	P	L	I	d2	DIN	QTY	PCB	€
962AT5100140200	UNC1/4	20	80	12	7	371	1	1	56,46
962AT5100380160	UNC3/8	16	90	14	9	371	1	1	81,68
962AT5100120130	UNC1/2	13	110	16	9	376	1	1	102,21
962AT5100340100	UNC3/4	10	125	25	14	376	1	1	180,92
962AT5110000080	UNC1"	8	160	30	20	376	1	1	337,20

962AT51	Ø	P	L	I	d2	DIN	QTY	PCB	€
962AT5100140280	UNF1/4	28	80	10	7	371	1	1	59,93
962AT5100380240	UNF3/8	24	100	14	9	371	1	1	87,03
962AT5100120200	UNF1/2	20	110	16	9	376	1	1	116,09
962AT5100340160	UNF3/4	16	125	18	14	376	1	1	203,05
962AT5110000120	UNF1"	12	140	25	20	376	1	1	398,55

MACHOS & COJINETES
CORE HOLE DRILLING

Ref.
BT1



MACHO DE MÁQUINA "FLASH CUT" ACERO COBALTO 5% (HSSE) | MÉTRICO/MÉTRICO FINO | AGUJERO PASANTE/CIEGO | APLICACIÓN: LATÓN / BRONCE

"FLASH CUT" MACHINE TAP COBALT STEEL 5% (HSSE) | METRIC/METRIC FINE | THROUGH/BLIND HOLE | APPLICATION: BRASS / BRONZE

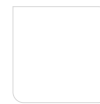
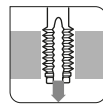
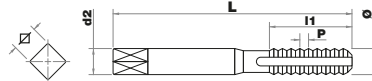

Latón
Brass



Bronce
Bronze

960BT11	Ø	P	L	l	d2	DIN	QTY	PCB	€
960BT1100300050	M3	0.5	56	10	3.5	371	1	1	14,01
960BT1100400070	M4	0.7	63	12	4.5	371	1	1	14,26
960BT1100500080	M5	0.8	70	14	6	371	1	1	14,26
960BT1100600100	M6	1	80	16	6	371	1	1	16,05
960BT1100800125	M8	1.25	90	18	8	371	1	1	17,89
960BT1101000150	M10	1.5	100	20	10	371	1	1	20,25
960BT1101200175	M12	1.75	110	22	9	376	1	1	24,90
960BT1101400200	M14	2	110	25	11	376	1	1	32,12
960BT1101600200	M16	2	110	28	12	376	1	1	38,52

960BT11	Ø	P	L	l	d2	DIN	QTY	PCB	€
960BT1100800100	MF8	1	90	18	8	371	1	1	21,39
960BT1101000100	MF10	1	90	18	10	374	1	1	23,24
960BT1101200150	MF12	1.5	100	22	9	374	1	1	29,21
960BT1101400150	MF14	1.5	100	22	11	374	1	1	34,47

MACHOS & COJINETES
CORE HOLE DRILLING

Ref.
BT1



**MACHO DE MÁQUINA "FLASH CUT" ACERO COBALTO 5% (HSSE) |
UNC/UNF | AGUJERO PASANTE/CIEGO | APLICACIÓN: LATÓN / BRONCE**
"FLASH CUT" MACHINE TAP COBALT STEEL 5% (HSSE) | UNC/UNF | THROUGH/
BLIND HOLE | APPLICATION: BRASS / BRONZE

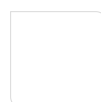
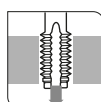
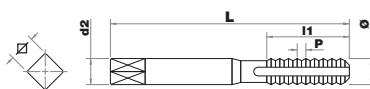
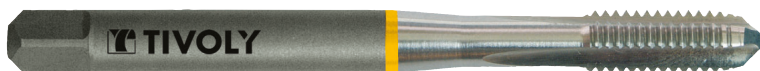

Latón
Brass



Bronce
Bronze

962BT11	Ø	P	L	I	d2	DIN	QTY	PCB	€
962BT1100140200	UNC1/4	20	80	16	7	371	1	1	24,85
962BT1100380160	UNC3/8	16	90	18	9	371	1	1	32,95
962BT1100120130	UNC1/2	13	110	25	9	376	1	1	44,50
962BT1100340100	UNC3/4	10	125	32	14	376	1	1	79,60
962BT1110000080	UNC1"	8	160	36	20	376	1	1	129,96

962BT11	Ø	P	L	I	d2	DIN	QTY	PCB	€
962BT1100140280	UNF1/4	28	80	16	7	371	1	1	26,18
962BT1100380240	UNF3/8	24	100	18	9	371	1	1	33,46
962BT1100120200	UNF1/2	20	110	25	9	376	1	1	50,48
962BT1100340160	UNF3/4	16	125	32	14	376	1	1	88,36
962BT1110000120	UNF1"	12	140	32	20	376	1	1	153,70

MACHOS & COJINETES
CORE HOLE DRILLING

Ref.
BT1



**MACHO DE MÁQUINA "FLASH CUT" ACERO COBALTO 5% (HSSE) |
BSP GAS | AGUJERO PASANTE/CIEGO | APLICACIÓN: LATÓN / BRONCE**
"FLASH CUT" MACHINE TAP COBALT STEEL 5% (HSSE) | BSP GAS | THROUGH/
BLIND HOLE | APPLICATION: BRASS / BRONZE

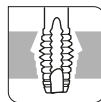
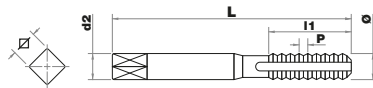
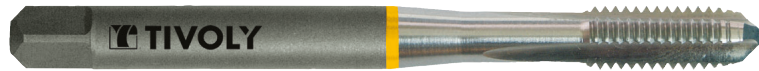

Latón
Brass



Bronce
Bronze

963BT11	Ø	P	L	I	d2	DIN	QTY	PCB	€
963BT1100180280	G1/8	28	90	18	7	5156	1	1	32,67
963BT1100140190	G1/4	19	100	22	11	5156	1	1	48,43
963BT1100380190	G3/8	19	100	25	12	5156	1	1	57,98
963BT1100120140	G1/2	14	125	25	16	5156	1	1	73,27
963BT1100340140	G3/4	14	140	28	20	5156	1	1	114,72
963BT1110000110	G1"	11	160	36	25	5156	1	1	178,01

MACHOS & COJINETES
CORE HOLE DRILLING

Ref.
CT1



**MACHO DE MÁQUINA "FLASH CUT" ACERO SINTERIZADO
PULVIMETALÚRGICO (HSSEE) TICN | MÉTRICO/MÉTRICO FINO |
AGUJERO PASANTE/CIEGO | APLICACIÓN: FUNDICIONES**

"FLASH CUT" MACHINE TAP HSSEE [ASP] TICN | METRIC/METRIC FINE |
THROUGH/BLIND HOLE | APPLICATION: CAST IRON

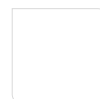
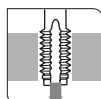
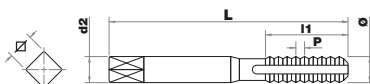
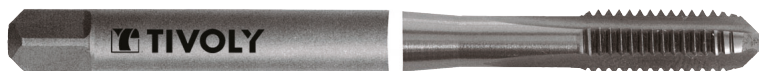

Fundición
gris
Grey
cast iron



Fundición
nodular
SG iron

960CT11	Ø	P	L	I	d2	DIN	QTY	PCB	€
960CT1100300050	M3	0.5	56	10	3.5	371	1	1	22,56
960CT1100400070	M4	0.7	63	12	4.5	371	1	1	22,56
960CT1100500080	M5	0.8	70	14	6	371	1	1	23,46
960CT1100600100	M6	1	80	16	6	371	1	1	24,47
960CT1100800125	M8	1.25	90	18	8	371	1	1	28,79
960CT1101000150	M10	1.5	100	20	10	371	1	1	35,08
960CT1101200175	M12	1.75	110	22	9	376	1	1	49,73
960CT1101400200	M14	2	110	25	11	376	1	1	67,22
960CT1101600200	M16	2	110	28	12	376	1	1	72,62

960CT11	Ø	P	L	I	d2	DIN	QTY	PCB	€
960CT1100800100	MF8	1	90	18	8	371	1	1	32,24
960CT1101000100	MF10	1	90	18	10	371	1	1	39,31
960CT1101200150	MF12	1.5	100	22	9	374	1	1	49,81
960CT1101400150	MF14	1.5	100	22	11	374	1	1	71,81

MACHOS & COJINETES
CORE HOLE DRILLING

Ref.
CT1



**MACHO DE MÁQUINA "FLASH CUT" ACERO SINTERIZADO
PULVIMETALÚRGICO (HSSEE) TICN | UNC/UNF | AGUJERO PASANTE/
CIEGO | APLICACIÓN: FUNDICIONES**

"FLASH CUT" MACHINE TAP HSSEE [ASP] TICN | UNC/UNF | THROUGH/BLIND
HOLE | APPLICATION: CAST IRON

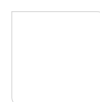
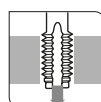
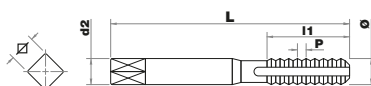
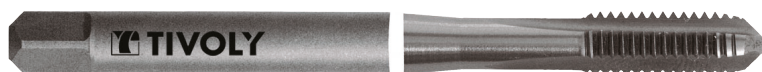

Fundición
gris
Grey
cast iron



Fundición
nodular
SG iron

962CT11	Ø	P	L	I	d2	DIN	QTY	PCB	€
962CT1100140200	UNC1/4	20	80	16	7	371	1	1	38,41
962CT1100380160	UNC3/8	16	90	18	9	371	1	1	50,93
962CT1100120130	UNC1/2	13	110	25	9	376	1	1	68,83
962CT1100340100	UNC3/4	10	125	32	14	376	1	1	123,03
962CT1110000080	UNC1"	8	160	36	20	376	1	1	200,91

962CT11	Ø	P	L	I	d2	DIN	QTY	PCB	€
962CT1100140280	UNF1/4	28	80	16	7	371	1	1	40,51
962CT1100380240	UNF3/8	24	100	18	9	371	1	1	51,69
962CT1100120200	UNF1/2	20	110	25	9	376	1	1	77,98
962CT1100340160	UNF3/4	16	125	32	14	376	1	1	136,60
962CT1110000120	UNF1"	12	140	32	20	376	1	1	237,53

MACHOS & COJINETES
CORE HOLE DRILLING

Ref.
CT1



**MACHO DE MÁQUINA "FLASH CUT" ACERO SINTERIZADO
PULVIMETALÚRGICO (HSSEE) TICN | BSP GAS | AGUJERO PASANTE/
CIEGO | APLICACIÓN: FUNDICIONES**

"FLASH CUT" MACHINE TAP HSSEE [ASP] TICN | BSP GAS | THROUGH/BLIND
HOLE | APPLICATION: CAST IRON

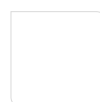
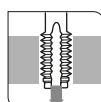
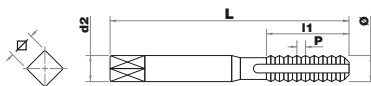
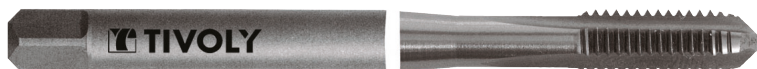

Fundición
gris
Grey
cast iron



Fundición
nodular
SG iron

963CT11	Ø	P	L	I	d2	DIN	QTY	PCB	€
963CT1100180280	G1/8	28	90	18	7	5156	1	1	53,43
963CT1100140190	G1/4	19	100	22	11	5156	1	1	79,25
963CT1100380190	G3/8	19	100	25	12	5156	1	1	94,89
963CT1100120140	G1/2	14	125	25	16	5156	1	1	119,90
963CT1100340140	G3/4	14	140	28	20	5156	1	1	187,73
963CT1110000110	G1"	11	160	36	25	5156	1	1	291,26

MACHOS & COJINETES
CORE HOLE DRILLING

MACHOS Y COJINETES DE ROSCAR
TAPPING & THREADING

- **COJINETES M-MF** **168**
DIES M-MF
- **COJINETES UNC-UNF** **170**
DIES UNC-UNF
- **COJINETES BSW** **172**
DIES BSW
- **COJINETES BSP GAS** **173**
DIES BSP GAS



COJINETE MULTIAPLICACIÓN ACERO COBALTO 5% (HSSE) | VAPORIZADO | MÉTRICO

MULTI-APPLICATION DIE COBALT STEEL 5% HSSE | STEAM TREATED | METRIC



Aceros aleados
200-700 N/mm²
Alloyed steels
200-700N/mm²



Aceros aleados
y tratados
< 950N/mm²
Heat Treatable
Steels
<950N/mm²



Aceros
inoxidables
austeníticos
Austenitic
stainless
steels

1100411	Ø	P	H	d2	EN	QTY	PCB	€
1100411020040	M2	0.4	5	16	22568	1	1	32,51
1100411025045	M2,5	0.45	5	16	22568	1	1	28,44
1100411030050	M3	0.5	5	20	22568	1	1	26,42
1100411040070	M4	0.7	5	20	22568	1	1	26,42
1100411050080	M5	0.8	7	20	22568	1	1	24,78
1100411060100	M6	1	7	20	22568	1	1	24,78
1100411070100	M7	1	9	25	22568	1	1	31,28
1100411080125	M8	1.25	9	25	22568	1	1	26,42
1100411090125	M9	1.25	9	25	22568	1	1	34,52
1100411100150	M10	1.5	11	30	22568	1	1	33,53
1100411110150	M11	1.5	11	30	22568	1	1	41,64
1100411120175	M12	1.75	14	38	22568	1	1	41,64
1100411140200	M14	2	14	38	22568	1	1	41,64
1100411160200	M16	2	18	45	22568	1	1	56,48
1100411180250	M18	2.5	18	45	22568	1	1	58,06
1100411200250	M20	2.5	18	45	22568	1	1	58,06
1100411220250	M22	2.5	22	55	22568	1	1	83,67
1100411240300	M24	3	22	55	22568	1	1	83,67
1100411270300	M27	3	25	65	22568	1	1	119,61
1100411300350	M30	3.5	25	65	22568	1	1	119,61
1100411330350	M33	3.5	25	65	22568	1	1	142,14
1100411360400	M36	4	25	65	22568	1	1	142,14
1100411390400	M39	4	30	75	22568	1	1	203,06
1100411420450	M42	4.5	30	75	22568	1	1	223,36



ESTUCHE DE COJINETES

DIES SET



11004170007	€
M3-M4-M5-M6-M8-M10-M12	208,45

COJINETE MULTIAPLICACIÓN ACERO COBALTO 5% (HSSE) | VAPORIZADO | MÉTRICO FINO

MULTI-APPLICATION DIE COBALT STEEL 5% HSSE | STEAM TREATED | METRIC FINE

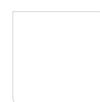
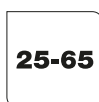

Aceros aleados
200-700 N/mm²
Alloyed steels
200-700N/mm²



Aceros aleados
y tratados
< 950N/mm²
Heat Treatable
Steels
<950N/mm²



Aceros
inoxidables
austeníticos
Austenitic
stainless
steels

1100441	Ø	P	H	d2	EN	QTY	PCB	€
1100441080100	MF8	1	9	25	22568	1	1	31,69
1100441100100	MF10	1	11	30	22568	1	1	40,83
1100441100125	MF10	1.25	11	30	22568	1	1	41,43
1100441120100	MF12	1	10	38	22568	1	1	46,69
1100441120125	MF12	1.25	10	38	22568	1	1	51,78
1100441120150	MF12	1.5	10	38	22568	1	1	45,48
1100441140100	MF14	1	10	38	22568	1	1	48,96
1100441140125	MF14	1.25	10	38	22568	1	1	52,41
1100441140150	MF14	1.5	10	38	22568	1	1	50,75
1100441160150	MF16	1.5	14	45	22568	1	1	64,57
1100441180150	MF18	1.5	14	45	22568	1	1	65,40
1100441200150	MF20	1.5	14	45	22568	1	1	66,62
1100441220150	MF22	1.5	16	55	22568	1	1	88,72
1100441240150	MF24	1.5	16	55	22568	1	1	93,50
1100441300150	MF30	1.5	18	65	22568	1	1	125,71

MACHOS & COJINETES
CORE HOLE DRILLING



COJINETE HSS | UNC | APLICACIÓN: ACEROS SEMI-DUROS HASTA 700 N/mm²

HSS DIN DIES | UNC | APPLICATION: SEMI-HARD STEELS UP TO 700 N/mm²



HSS

BRIGHT UNCOATED

EN 22568

20-45

GUN B FORM

UNC



A

Aceros débilmente aleados <400 N/mm²
Low alloyed steels <400N/mm²

B

Aceros aleados y tratados < 700N/mm²
Heat Treatable Steels <700N/mm²

1100471	Ø	P	H	d2	EN	QTY	PCB	€
11004710005	UNC5	40	5	20	22568	1	1	24,64
11004710006	UNC6	32	5	20	22568	1	1	23,66
11004710008	UNC8	32	5	20	22568	1	1	23,32
11004710010	UNC10	24	7	20	22568	1	1	24,30
11004710012	UNC12	24	7	20	22568	1	1	24,64
11004710104	UNC1/4	20	7	20	22568	1	1	24,30
11004710516	UNC5/16	18	9	25	22568	1	1	26,11
11004710308	UNC3/8	16	11	30	22568	1	1	32,80
11004710716	UNC7/16	14	11	30	22568	1	1	32,80
11004710102	UNC1/2	13	14	38	22568	1	1	37,51
11004710304	UNC3/4	10	18	45	22568	1	1	53,51



COJINETE HSS | UNF | APLICACIÓN: ACEROS SEMI-DUROS HASTA 700 N/mm²

HSS DIN DIES | UNF | APPLICATION: SEMI-HARD STEELS UP TO 700 N/mm²



Aceros débilmente aleados <400 N/mm²
Low alloyed steels <400N/mm²



Aceros aleados y tratados < 700N/mm²
Heat Treatable Steels <700N/mm²

1100481	Ø	P	H	d2	EN	QTY	PCB	€
11004810005	UNF5	44	5	20	22568	1	1	24,64
11004810006	UNF6	40	5	20	22568	1	1	23,66
11004810008	UNF8	36	5	20	22568	1	1	23,66
11004810010	UNF10	32	7	20	22568	1	1	24,30
11004810012	UNF12	28	7	20	22568	1	1	24,64
11004810104	UNF1/4	28	7	20	22568	1	1	24,30
11004810516	UNF5/16	24	9	25	22568	1	1	26,11
11004810308	UNF3/8	24	11	30	22568	1	1	32,80
11004810716	UNF7/16	20	11	30	22568	1	1	32,80
11004810102	UNF1/2	20	10	38	22568	1	1	37,51
11004810304	UNF3/4	16	11	45	22568	1	1	53,51

MACHOS & COJINETES
CORE HOLE DRILLING



COJINETE HSS | BSW | APLICACIÓN: ACEROS SEMI-DUROS HASTA 700 N/mm²

HSS DIN DIES | BSW | APPLICATION: SEMI-HARD STEELS UP TO 700 N/mm²



HSS

BRIGHT UNCOATED

EN 24231

20-55

GUN B FORM

BSW



A

Aceros débilmente aleados <400 N/mm²
Low alloyed steels <400N/mm²

B

Aceros aleados y tratados < 700N/mm²
Heat Treatable Steels <700N/mm²

1100501	Ø	P	H	d2	EN	QTY	PCB	€
11005010108	BSW1/8	40	5	20	24231	1	1	23,66
11005010532	BSW5/32	32	5	20	24231	1	1	23,32
11005010316	BSW3/16	24	7	20	24231	1	1	24,30
11005010104	BSW1/4	20	7	20	24231	1	1	23,66
11005010516	BSW5/16	18	9	25	24231	1	1	25,12
11005010308	BSW3/8	16	11	30	24231	1	1	31,15
11005010716	BSW7/16	14	11	30	24231	1	1	33,92
11005010102	BSW1/2	12	14	38	24231	1	1	38,49
11005010508	BSW5/8	11	18	45	24231	1	1	51,86
11005010304	BSW3/4	10	18	45	24231	1	1	57,09
11005010708	BSW7/8	9	22	55	24231	1	1	82,50
11005011000	BSW1"	8	22	55	24231	1	1	86,44



COJINETE HSS | **BSP GAS** | APLICACIÓN: ACEROS SEMI-DUROS HASTA 700 N/mm²

HSS DIN DIES | BSP GAS | APPLICATION: SEMI-HARD STEELS UP TO 700 N/mm²



HSS

BRIGHT UNCOATED

EN 24231

30-90

GUN B FORM

BSP G



A

Aceros débilmente aleados <400 N/mm²
Low alloyed steels <400N/mm²

B

Aceros aleados y tratados < 700N/mm²
Heat Treatable Steels <700N/mm²

1100491	Ø	P	H	d2	EN	QTY	PCB	€
11004910108	G1/8	28	11	30	24231	1	1	34,73
11004910104	G1/4	19	10	38	24231	1	1	36,52
11004910308	G3/8	19	14	45	24231	1	1	50,54
11004910102	G1/2	14	14	45	24231	1	1	50,54
11004910508	G5/8	14	16	55	24231	1	1	78,74
11004910304	G3/4	14	16	55	24231	1	1	67,83
11004910708	G7/8	14	18	65	24231	1	1	102,42
11004911000	G1	11	18	65	24231	1	1	102,42
11004911104	G1"1/4	11	20	75	24231	1	1	162,86
11004911102	G1"1/2	11	22	90	24231	1	1	255,02

MACHOS & COJINETES
CORE HOLE DRILLING

 **GIRAMACHOS**
TAP WRENCH



**TIVOLY
NORM**

1110011	N°	M to M	QTY	PCB	€
11100110000	N°0	M1-6	1	1	13,78
11100110010	N°1	M3-8	1	1	14,67
11100110015	N°1,5	M3-12	1	1	19,25
11100110020	N°2	M4-14	1	1	24,13
11100110030	N°3	M6-20	1	1	32,93
11100110040	N°4	M9-27	1	1	48,45

MACHOS & COJINETES
CORE HOLE DRILLING

 **PORTAMACHOS REVERSIBLE CON TRINQUETE**
TAP WRENCH WITH RATCHET



**TIVOLY
NORM**

1110031	Ø	L	QTY	PCB	€
11100310001	2 - 5	85	1	1	16,10
11100310002	4,5 - 6,5	105	1	1	23,55
11100310003	2 - 5	250	1	1	35,23
11100310004	4,5 - 6,5	300	1	1	42,99



JUEGO DE EXTRACTORES DE TORNILLOS ROTOS

+ BROKEN PIN REMOVER SET



120968	Ø	QTY	PCB	€
12096810001	M3-M18	5	1	16,73
12096810002	M3-M24	6	1	25,27

MACHOS & COJINETES
CORE HOLE DRILLING

PORTA COJINETES | ACERO
 DIE HOLDER | STEEL BODY AND HANDLE



**TIVOLY
NORM**

1110041	d2	TIV.	H		QTY	PCB	€
11100410254	25.4	-			1	1	11,43
11100410381	38.1	-			1	1	16,19
11100410508	50.8	-			1	1	27,11
11100410635	63.5	-			1	1	44,60
11100410205	20	-	5	-	1	1	20,08
11100410207	20	-	7	-	1	1	20,08
11100410259	25	-	9	-	1	1	23,74
11100413011	30	-	11	-	1	1	27,07
11100413810	38	-	10	-	1	1	35,35
11100413814	38	-	14	-	1	1	35,35
11100414514	45	-	14	-	1	1	45,28
11100414518	45	-	18	-	1	1	47,45
11100415516	55	-	16	-	1	1	51,77
11100415522	55	-	22	-	1	1	57,57
11100416518	65	-	18	-	1	1	66,96
11100416525	65	-	25	-	1	1	66,96

ALARGADOR DE PORTA COJINETES | ACERO
 END DIE HOLDER | STEEL BODY



**TIVOLY
NORM**

1110051	N°	TIV.	QTY	PCB	€
11100510254	25,4	-	1	1	53,97
11100510381	38,1	-	1	1	102,84

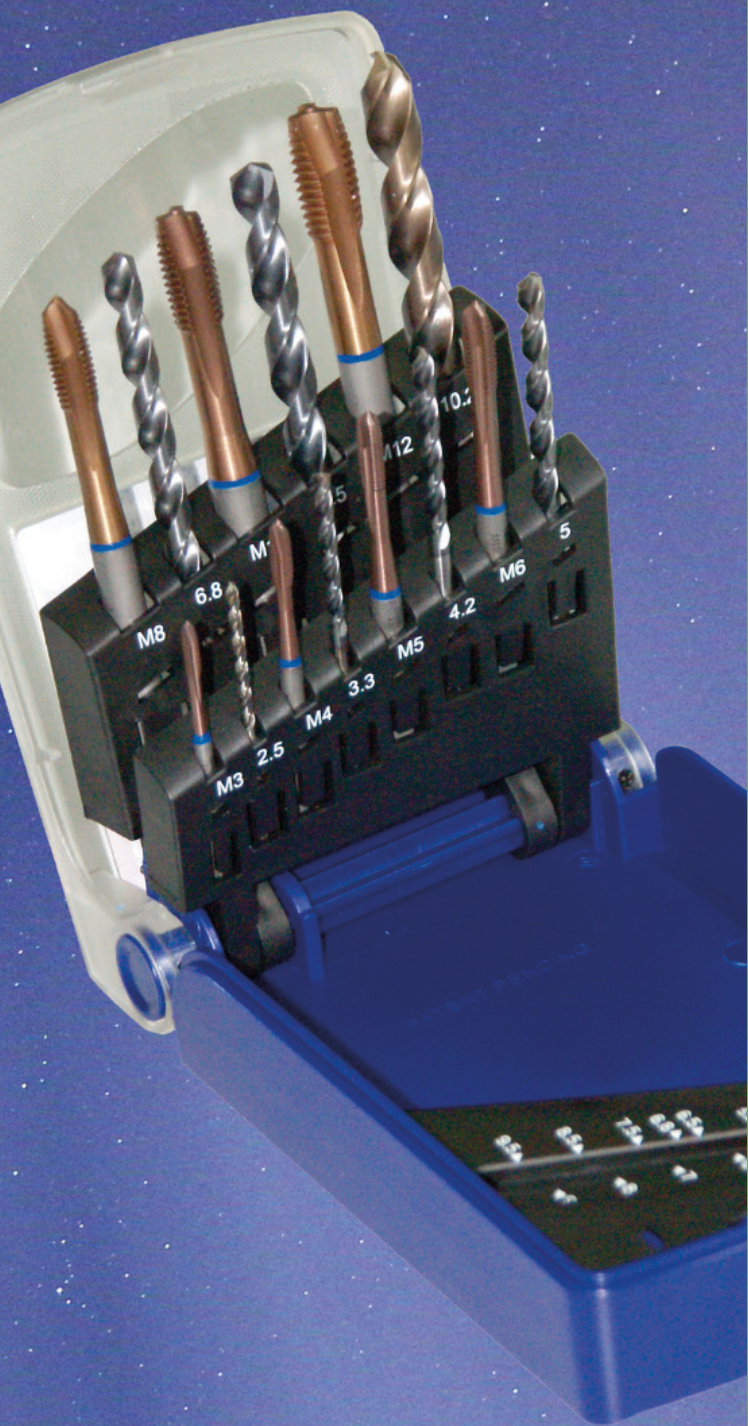

MACHOS Y COJINETES DE ROSCAR
TAPPING & THREADING

■ **ESTUCHES**
SETS

178

MACHOS & COJINETES
CORE HOLE DRILLING

ESTUCHE DE MACHOS AGUJERO PASANTE (ref. 252) + BROCAS PREVIAS DIN 338 HSS (ref. 530) | APLICACIÓN: ACEROS BLANDOS HASTA 400 N/mm²

SET OF TAPS THROUGH HOLE (REF. 252) + PREVIOUS HOLE DRILL DIN 338 HSS (REF. 530) | APPLICATION: SOFT STEELS UP TO 400N/mm²

REFERENCIA	M	€
16025270003	M3 a M12	77,10

COMP.
MACHOS | TAPS
M3-M4-M5-M6-M8-M10-M12
BROCAS | DRILLS
Ø 2,5-3,3-4,2-5-6,8-8,5-10,2



ESTUCHE DE MACHOS HELICOIDALES AGUJERO CIEGO (ref. 255) + BROCAS PREVIAS DIN 338 HSS (ref. 530) | APLICACIÓN: ACEROS BLANDOS HASTA 400 N/mm²

SET OF TAPS BLIND HOLE (REF. 255) + PREVIOUS HOLE DRILL DIN 338 HSS (REF. 530) | APPLICATION: SOFT STEELS UP TO 400N/mm²

REFERENCIA	M	€
16025570003	M3 a M12	99,44

COMP.
MACHOS | TAPS
M3-M4-M5-M6-M8-M10-M12
BROCAS | DRILLS
Ø 2,5-3,3-4,2-5-6,8-8,5-10,2



ESTUCHE DE MACHOS MULTI-APLICACIÓN AGUJERO PASANTE (ref. 202) + BROCAS PREVIAS DIN 338 HSSCO (ref. 550) | APLICACIÓN: ACEROS SEMI-DUROS HASTA 700 N/mm²

SET OF MULTI-APPLICATION TAPS THROUGH HOLE (REF. 202) + PREVIOUS HOLE DRILL DIN 338 HSS (REF. 550) | APPLICATION: SEMI-HARD STEELS UP TO 700N/mm²

REFERENCIA	M	€
96020270003	M3 A M12	111,11

COMP.
MACHOS | TAPS
M3-M4-M5-M6-M8-M10-M12
BROCAS | DRILLS
Ø 2,5-3,3-4,2-5-6,8-8,5-10,2

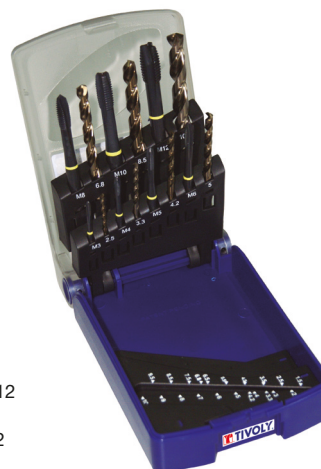

ESTUCHE DE MACHOS MULTI-APLICACIÓN | AGUJERO CIEGO (ref. 205) + BROCAS PREVIAS DIN 338 HSSCO (ref. 550) | APLICACIÓN: ACEROS SEMI-DUROS HASTA 700 N/mm²

SET OF MULTI-APPLICATION TAPS BLIND HOLE (REF. 202) + PREVIOUS HOLE DRILL DIN 338 HSS (REF. 550) | APPLICATION: SEMI-HARD STEELS UP TO 700N/mm²

REFERENCIA	M	€
96020570003	M3 A M12	137,82

COMP.
MACHOS | TAPS
M3-M4-M5-M6-M8-M10-M12
BROCAS | DRILLS
Ø 2,5-3,3-4,2-5-6,8-8,5-10,2



ESTUCHE DE MACHOS “FLASH CUT” AGUJERO PASANTE (ref. ST2) + BROCAS PREVIAS DIN 338 HSS FURIUS (ref. 541) | APLICACIÓN: ACEROS DUROS HASTA 950 N/mm²

SET OF FLASH CUT TAPS THROUGH HOLE (REF. ST2) + PREVIOUS HOLE DRILL DIN 338 HSS FURIUS (REF. 541)
APPLICATION: HARD STEELS UP TO 950 N/mm²

REFERENCIA	M	€
960ST270003	M3 a M12	170,31

COMP. **MACHOS** | TAPS
M3-M4-M5-M6-M8-M10-M12
BROCAS | DRILLS
Ø 2,5-3,3-4,2-5-6,8-8,5-10,2



ESTUCHE DE MACHOS “FLASH CUT” HELICOIDALES AGUJERO CIEGO (ref. ST5) + BROCAS PREVIAS DIN 338 HSS FURIUS (ref. 541) | APLICACIÓN: ACEROS DUROS HASTA 950 N/mm²

SET OF FLASH CUT TAPS SPIRAL FLUTE BLIND HOLE (REF. ST5) + PREVIOUS HOLE DRILL DIN 338 HSS FURIUS (REF. 541)
APPLICATION: HARD STEELS UP TO 950 N/mm²

REFERENCIA	M	€
960ST570003	M3 A M12	193,98

COMP. **MACHOS** | TAPS
M3-M4-M5-M6-M8-M10-M12
BROCAS | DRILLS
Ø 2,5-3,3-4,2-5-6,8-8,5-10,2

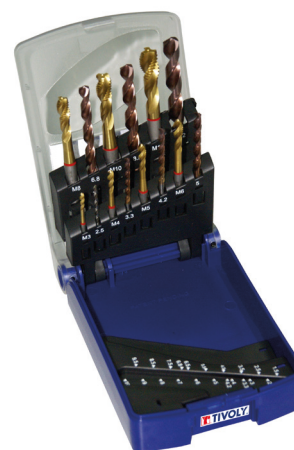

ESTUCHE DE MACHOS “FLASH CUT” AGUJERO PASANTE (ref. IT2) + BROCAS PREVIAS DIN 338 HSSCO TBX (ref. 561) | APLICACIÓN: ACEROS INOXIDABLES

SET OF FLASH CUT TAPS THROUGH HOLE (REF. IT2) + PREVIOUS HOLE DRILL HSSECO TBX (REF. 561)
APPLICATION: STAINLESS STEELS

REFERENCIA	M	€
960IT270003	M3 A M12	214,20

COMP. **MACHOS** | TAPS
M3-M4-M5-M6-M8-M10-M12
BROCAS | DRILLS
Ø 2,5-3,3-4,2-5-6,8-8,5-10,2



ESTUCHE DE MACHOS “FLASH CUT” AGUJERO CIEGO (ref. IT5) + BROCAS PREVIAS DIN 338 HSSCO TBX (ref. 561) | APLICACIÓN: ACEROS INOXIDABLES

SET OF MULTI-APPLICATION TAPS BLIND HOLE (REF. IT5) + PREVIOUS HOLE DRILL DIN 338 HSSECO TBX (REF. 561)
APPLICATION: STAINLESS STEELS

REFERENCIA	M	€
960IT570003	M3 A M12	246,82

COMP. **MACHOS** | TAPS
M3-M4-M5-M6-M8-M10-M12
BROCAS | DRILLS
Ø 2,5-3,3-4,2-5-6,8-8,5-10,2



ESTUCHE | 7X3 ROSCADO MANUAL | HSS | DIN 352 | M3>M12
 + 7 SETS 3 HAND TAPS | HSS | DIN 352 | M3 > M12



Aceros para tratamiento térmico 200-700 N/mm²
 Steels for heat treatment 200-700N/mm²

80511670001		
QTY	PCB	€
21	1	213,80

ESTUCHE | MTF31 | 7 X 3 ROSCADO MANUAL | HSS | DIN 352 + 7 COJINETES HSS ISO 25,4 | M3>M12 | +1 G. N°1,5+1 P. C. 25,4 + 1 AVELLANADOR

SET | MTF31 | 7 SETS 3 HAND TAPS HSS | DIN 352 + 7 DIES HSS ISO 25,4 | M3 À M12 | + 1 TW N°1,5+1 DH 25,4+1 COUNTERSINK



Aceros para tratamiento térmico 200-700 N/mm²
 Steels for heat treatment 200-700N/mm²

11900870001		
QTY	PCB	€
31	1	336,02

SET DE MACHOS AGUJERO PASANTE (ref. 252) + BROCAS PREVIAS DIN 338 HSS (ref. 530) | APLICACIÓN: ACEROS BLANDOS HASTA 400 N/mm²
 SET OF TAPS THROUGH HOLE (REF. 252) + PREVIOUS HOLE DRILL DIN 338 HSS (REF. 530) | APPLICATION: SOFT STEELS UP TO 400N/mm²



1602527	M	Paso	Ø Broca	€
160252700300050	M3	0,50	2,5	19,42
160252700400070	M4	0,70	3,3	19,86
160252700500080	M5	0,80	4,2	19,86
160252700600100	M6	1,00	5	21,72
160252700800125	M8	1,25	6,8	24,44
160252701000150	M10	1,50	8,5	30,08

SET DE MACHOS HELICOIDALES AGUJERO CIEGO (ref. 255) + BROCAS PREVIAS DIN 338 HSS (ref. 530) | APLICACIÓN: ACEROS BLANDOS HASTA 400 N/mm²

SET OF TAPS BLIND HOLE (REF. 255) + PREVIOUS HOLE DRILL DIN 338 HSS (REF. 530) | APPLICATION: SOFT STEELS UP TO 400N/mm²



1602557	M	Paso	Ø Broca	€
160255700300050	M3	0,50	2,5	22,90
160255700400070	M4	0,70	3,3	22,94
160255700500080	M5	0,80	4,2	22,00
160255700600100	M6	1,00	5	24,18
160255700800125	M8	1,25	6,8	28,78
160255701000150	M10	1,50	8,5	34,22

SET DE MACHOS MULTI-APLICACIÓN AGUJERO PASANTE (ref. 202) + BROCAS PREVIAS DIN 338 HSSCO (ref. 550) | APLICACIÓN: ACEROS SEMI-DUROS HASTA 700 N/mm²

SET OF MULTI-APPLICATION TAPS THROUGH HOLE (REF. 202) + PREVIOUS HOLE DRILL DIN 338 HSS (REF. 550) | APPLICATION: SEMI-HARD STEELS UP TO 700N/mm²



9602027	M	Paso	Ø Broca	€
960202700300050	M3	0,50	2,5	26,78
960202700400070	M4	0,70	3,3	27,40
960202700500080	M5	0,80	4,2	27,40
960202700600100	M6	1,00	5	29,52
960202700800125	M8	1,25	6,8	33,76
960202701000150	M10	1,50	8,5	41,52

SET DE MACHOS MULTI-APLICACIÓN AGUJERO CIEGO (ref. 205) + BROCAS PREVIAS DIN 338 HSSCO (ref. 550) | APLICACIÓN: ACEROS SEMI-DUROS HASTA 700 N/mm²

SET OF MULTI-APPLICATION TAPS THROUGH HOLE (REF. 202) + PREVIOUS HOLE DRILL DIN 338 HSS (REF. 550) | APPLICATION: SEMI-HARD STEELS UP TO 700N/mm²



9602057	M	Paso	Ø Broca	€
960205700300050	M3	0,50	2,5	31,58
960205700400070	M4	0,70	3,3	31,60
960205700500080	M5	0,80	4,2	30,36
960205700600100	M6	1,00	5	33,34
960205700800125	M8	1,25	6,8	39,70
960205701000150	M10	1,50	8,5	47,18

SET DE MACHOS “FLASH CUT” AGUJERO PASANTE (ref. ST2) + BROCAS PREVIAS DIN 338 HSS FURIUS (ref. 541) | APLICACIÓN: ACEROS DUROS HASTA 950 N/mm²

SET OF “FLASH CUT” TAPS THROUGH HOLE (REF. ST2) + PREVIOUS HOLE DRILL DIN 338 HSS FURIUS (REF. 541) | APPLICATION: HARD STEELS UP TO 950N/mm²



960ST27	M	Paso	Ø Broca	€
960ST2700300050	M3	0,50	2,5	33,00
960ST2700400070	M4	0,70	3,3	33,66
960ST2700500080	M5	0,80	4,2	33,66
960ST2700600100	M6	1,00	5	36,34
960ST2700800125	M8	1,25	6,8	41,72
960ST2701000150	M10	1,50	8,5	52,82

SET DE MACHOS “FLASH CUT” HELICOIDALES AGUJERO CIEGO (ref. ST5) + BROCAS PREVIAS DIN 338 HSS FURIUS (ref. 541) | APLICACIÓN: ACEROS DUROS HASTA 950 N/mm²

SET OF “FLASH CUT” TAPS BLIND HOLE (REF. ST5) + PREVIOUS HOLE DRILL DIN 338 HSS FURIUS (REF. 541) | APPLICATION: HARD STEELS UP TO 950N/mm²



960ST57	M	Paso	Ø Broca	€
960ST5700300050	M3	0,50	11	38,08
960ST5700400070	M4	0,70	10	38,12
960ST5700500080	M5	0,80	14	36,74
960ST5700600100	M6	1,00	14	39,86
960ST5700800125	M8	1,25	16	47,94
960ST5701000150	M10	1,50	16	55,34

SET DE MACHOS “FLASH CUT” AGUJERO PASANTE (ref. IT2) + BROCAS PREVIAS DIN 338 HSS FURIUS (ref. 541) | APLICACIÓN: ACEROS INOXIDABLES

SET OF “FLASH CUT” TAPS THROUGH HOLE (REF. ST2) + PREVIOUS HOLE DRILL DIN 338 HSS FURIUS (REF. 541) | APPLICATION: STAINLESS STEELS



960IT27	M	Paso	Ø Broca	€
960IT2700300050	M3	0,50	2,5	54,48
960IT2700400070	M4	0,70	3,3	54,32
960IT2700500080	M5	0,80	4,2	57,14
960IT2700600100	M6	1,00	5	59,62
960IT2700800125	M8	1,25	6,8	69,92
960IT2701000150	M10	1,50	8,5	84,26

SET DE MACHOS “FLASH CUT” HELICOIDALES AGUJERO CIEGO (ref. IT5) + BROCAS PREVIAS HSSCO TBX (ref. 561) | APLICACIÓN: ACEROS INOXIDABLES

SET OF “FLASH CUT” TAPS BLIND HOLE (REF. IT5) + PREVIOUS HOLE DRILL HSSCO TBX (REF. 561) | APPLICATION: STAINLESS STEELS



960IT57	M	Paso	Ø Broca	€
960IT5700300050	M3	0,50	2,5	56,70
960IT5700400070	M4	0,70	3,3	56,70
960IT5700500080	M5	0,80	4,2	58,26
960IT5700600100	M6	1,00	5	59,82
960IT5700800125	M8	1,25	6,8	72,34
960IT5701000150	M10	1,50	8,5	90,88

SET MIXTO DE MACHOS AGUJERO CIEGO Y PASANTE (ref. 252/255) + BROCAS PREVIAS DIN 338 HSS (ref. 530) | APLICACIÓN: ACEROS BLANDOS HASTA 400 N/mm²

MIXED SET OF TAPS THROUGH AND BLIND HOLE (REF. 252/255) + PREVIOUS HOLE DRILL DIN 338 HSS (REF. 530) | APPLICATION: SOFT STEELS UP TO 400N/mm²



1602507	M	Paso	Ø Broca	€
160250700300050	M3	0,50	2,5	21,16
160250700400070	M4	0,70	3,3	21,40
160250700500080	M5	0,80	4,2	20,93
160250700600100	M6	1,00	5	22,95
160250700800125	M8	1,25	6,8	26,61
160250701000150	M10	1,50	8,5	32,15

SET MIXTO DE MACHOS MULTI-APLICACIÓN AGUJERO CIEGO Y PASANTE (ref. 202/205) + BROCAS PREVIAS DIN 338 HSSCO (ref. 550) | APLICACIÓN: ACEROS SEMI-DUROS HASTA 700 N/mm²

MIXED SET OF MULTI-APPLICATION TAPS THROUGH AND BLIND HOLE (REF. 202/205) + PREVIOUS HOLE DRILL DIN 338 HSSCO (REF. 550) | APPLICATION: SEMI-HARD STEELS UP TO 700N/mm²



9602007	M	Paso	Ø Broca	€
960200700300050	M3	0,50	2,5	29,18
960200700400070	M4	0,70	3,3	29,50
960200700500080	M5	0,80	4,2	28,88
960200700600100	M6	1,00	5	31,63
960200700800125	M8	1,25	6,8	36,73
960200701000150	M10	1,50	8,5	44,35

SET MIXTO DE MACHOS "FLASH CUT" AGUJERO CIEGO Y PASANTE (ref. ST2/ST5) + BROCAS PREVIAS HSSCO TBX (ref.561) | APLICACIÓN: ACEROS DUROS HASTA 950 N/mm²

MIXED SET OF "FLASH CUT" TAPS THROUGH AND BLIND HOLE (REF. ST2/ST5) + PREVIOUS HOLE DRILL HSSCO TBX (REF. 561) | APPLICATION: HARD STEELS UP TO 950N/mm²



960ST07	M	Paso	Ø Broca	€
960ST0700300050	M3	0,50	2,5	35,54
960ST0700400070	M4	0,70	3,3	35,89
960ST0700500080	M5	0,80	4,2	35,20
960ST0700600100	M6	1,00	5	38,10
960ST0700800125	M8	1,25	6,8	44,83
960ST0701000150	M10	1,50	8,5	54,08

SET MIXTO DE MACHOS "FLASH CUT" AGUJERO CIEGO Y PASANTE (ref. IT2/IT5) + BROCAS PREVIAS HSSCO TBX (ref.561) | APLICACIÓN: ACEROS INOXIDABLES

MIXED SET OF "FLASH CUT" TAPS THROUGH AND BLIND HOLE (REF. ST2/ST5) + PREVIOUS HOLE DRILL HSSCO TBX (REF. 561) | APPLICATION: STAINLESS STEELS



960IT07	M	Paso	Ø Broca	€
960IT0700300050	M3	0,50	2,5	55,59
960IT0700400070	M4	0,70	3,3	55,51
960IT0700500080	M5	0,80	4,2	57,70
960IT0700600100	M6	1,00	5	59,72
960IT0700800125	M8	1,25	6,8	71,13
960IT0701000150	M10	1,50	8,5	87,57



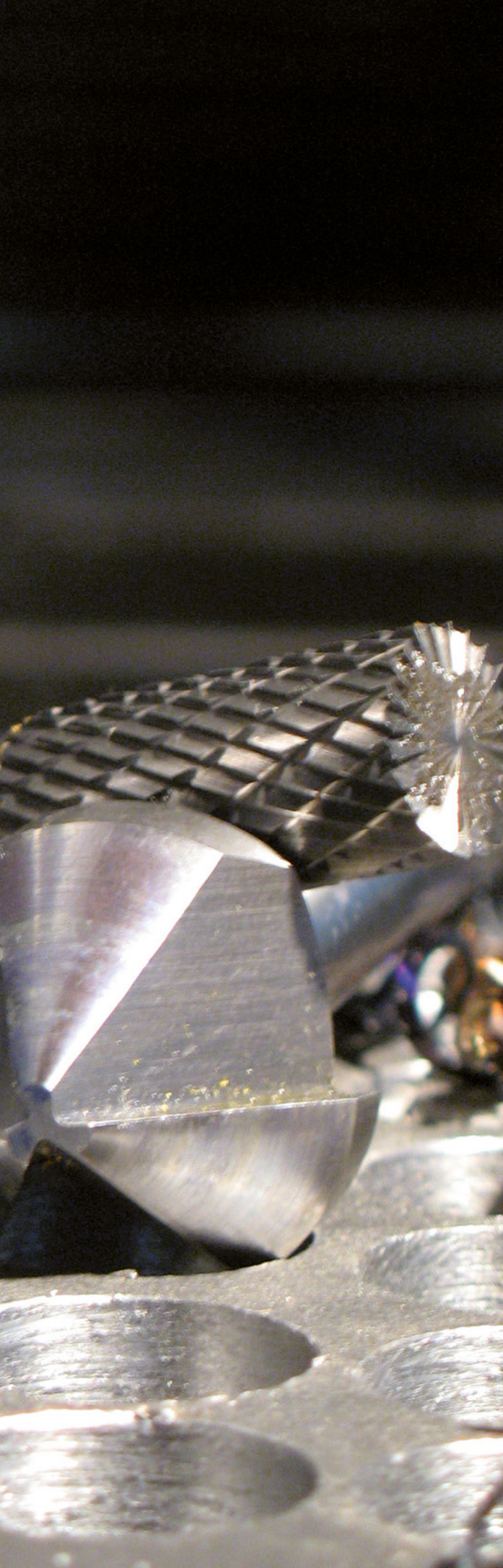

FRESADO MILLING

CATÁLOGO GENERAL
2021

- **AVELLANADOR** 186
COUNTERSINKERS
- **FRESAS LIMA** 189
ROTARY BURRS
- **FRESAS FRONTALES** 205
HSS END MILLS

FRESADO
MILLING

AVELLANADOR 90° ACERO COBALTO 5% (HSSE5) | DIN 335C | 3 CORTES | APLICACIÓN: ACEROS SEMI-DUROS HASTA 700 N/mm², INOXIDABLES Y ALUMINIO

COUNTERSINK 90° COBALT STEELS 5% (HSSE5) | DIN 335C | 3Z | APPLICATION: SEMI-HARD STEELS UP TO 700 N/mm², STAINLESS STEELS AND ALUMINIUM

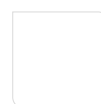
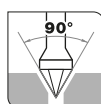
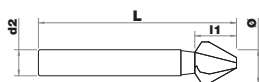

Aceros aleados
200-700 N/mm²
Alloyed steels
200-700N/mm²



Aceros
inoxidables
Stainless
Steels



Aleaciones
de aluminio
Aluminium
alloys

1033162	Ø	d2	L	QTY	PCB	€
10331620430	4,3	4	40	1	1	12,13
10331620530	5,3	4	40	1	1	12,13
10331620630	6,3	5	45	1	1	12,41
10331620800	8	6	50	1	1	13,72
10331620830	8,3	6	50	1	1	13,94
10331620940	9,4	6	50	1	1	15,35
10331621000	10	6	50	1	1	16,24
10331621040	10,4	6	50	1	1	16,85
10331621150	11,5	8	56	1	1	17,67
10331621240	12,4	8	56	1	1	17,91
10331621340	13,4	8	56	1	1	19,16
10331621500	15	10	60	1	1	20,55
10331621650	16,5	10	60	1	1	22,06
10331621900	19	10	63	1	1	22,06
10331622050	20,5	10	63	1	1	29,89
10331622300	23	10	57	1	1	30,57
10331622500	25	10	67	1	1	39,14
10331623100	31	12	71	1	1	61,73



**AVELLANADOR 90° ACERO COBALTO 5% (HSSE5) | DIN 335C | TiALN
| 3 CORTES | APLICACIÓN: ACEROS DUROS HASTA 950 N/mm²,
INOXIDABLES Y ALUMINIO**

COUNTERSINK 90° COBALT STEELS 5% (HSSE5) | DIN 335C | TiALN | 3Z |
APPLICATION: SEMI-HARD STEELS UP TO 700 N/mm², STAINLESS STEELS AND
ALUMINIUM

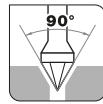
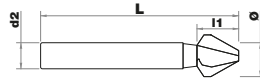

Aceros aleados
200-700 N/mm²
Alloyed steels
200-700N/mm²



Aceros aleados
y tratados
< 950N/mm²
Heat Treatable
Steels
<950N/mm²



Aceros
inoxidables
Stainless
Steels



Aleaciones
de aluminio
Aluminium
alloys

1036631	Ø	d2	L	QTY	PCB	€
10366310630	6.3	5	45	1	1	22,56
10366310830	8.3	6	50	1	1	27,09
10366311040	10.4	6	50	1	1	31,64
10366311240	12.4	8	56	1	1	32,65
10366311650	16.5	10	60	1	1	38,70
10366312050	20.5	10	63	1	1	51,61
10366312500	25	10	67	1	1	71,19

ESTUCHE | FNH06 | 6 AVELLANADORES 90° HSSE5 Ø 6,3 / 8,3 / 10,4 / 12,4 / 16,5 / 20,5
 SET | FNH06 | 6 COUNTERSINK 90° HSSE5
 Ø 6,3 / 8,3 / 10,4 / 12,4 / 16,5 / 20,5



10331670005		
QTY	PCB	€
6	1	107,99



ESTUCHE | FNH05 | 5 AVELLANADORES 90° HSSE5 Ø 10,4 / 16,5 / 20,5 / 25 / 31
 SET | FNH05 | 5 COUNTERSINK 90° HSSE5
 Ø 10,4 / 16,5 / 20,5 / 25 / 31



10331670002		
QTY	PCB	€
5	1	167,22



ESTUCHE | FNH06 | TIAIN | 6 AVELLANADORES 90° HSSE5 TIALN Ø 6,3/8,3/10,4/12,4/16,5/20,5
 SET | FNH06 | TIAIN | 6 COUNTERSINK 90° HSSE5
 Ø 6,3/8,3/10,4/12,4/16,5/20,5



10366370001		
QTY	PCB	€
6	1	165,04



ESTUCHE | FLH | 6 ALOJAMIENTO TORNILLOS 180° HSSE5, Ø 6/8/10/11/15/18 mm
 SET | FLH | 6 COUNTERBORE 180° HSSE5
 Ø 6/8/10/11/15/18 mm



10310370002		
QTY	PCB	€
6	1	224,88



FRESA LIMA METAL DURO | CILÍNDRICA
 CARBIDE ROTARY BURRS | CYLINDRICAL

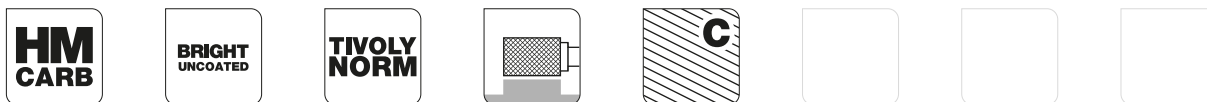
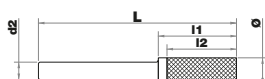

CDE

Aceros aleados y tratados
 700-1400 N/mm²
 Heat treatables steels
 700-1400N/mm²

FGH

Aceros
 inoxidables
 Stainless
 Steel

1031601	Ø	d2	L	I2	QTY	PCB	€
10316010400	4	6	50	14	1	1	23,18
10316010600	6	6	50	16	1	1	23,18
10316010800	8	6	65	20	1	1	27,94
10316011000	10	6	65	20	1	1	31,57
10316011200	12	6	70	25	1	1	41,90
10316011600	16	8	70	25	1	1	59,49
103160116006	16	6	70	25	1	1	59,49
103160120006	20	6	70	25	1	1	86,81

FRESA LIMA METAL DURO | CILÍNDRICA
 CARBIDE ROTARY BURRS | CYLINDRICAL

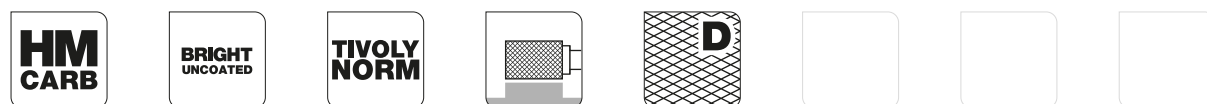
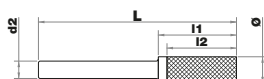

AB

Aceros aleados
 200-700 N/mm²
 Alloyed steels
 200-700N/mm²

IJ

Fundiciones
 Cast iron

NO

Aleaciones
 de cobre
 Copper
 alloys

1031611	Ø	d2	L	I2	QTY	PCB	€
10316110400	4	6	50	14	1	1	27,68
10316110600	6	6	50	16	1	1	27,68
10316110800	8	6	65	20	1	1	33,26
10316111000	10	6	65	20	1	1	37,43
10316111200	12	6	70	25	1	1	50,26
10316111600	16	8	70	25	1	1	70,63
103161116006	16	6	70	25	1	1	70,63

FRESADO
 MILLING

FRESA LIMA METAL DURO | CILÍNDRICA | CORTE AL CENTRO
 + CARBIDE ROTARY BURRS | CYLINDRICAL END CUTTING

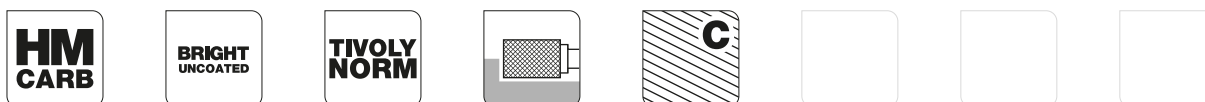
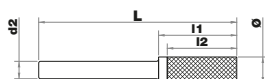

CDE Aceros aleados y tratados
 700-1400 N/mm²
 Heat treatables steels
 700-1400N/mm²

1031621	Ø	d2	L	I2	QTY	PCB	€
10316210400	4	6	50	14	1	1	25,43
10316210600	6	6	50	16	1	1	25,43
10316210800	8	6	65	20	1	1	30,45
10316211000	10	6	65	20	1	1	34,63
10316211200	12	6	70	25	1	1	46,07
10316211600	16	8	70	25	1	1	65,61
103162116006	16	6	70	25	1	1	65,61

FGH Aceros inoxidables
 Stainless Steel

FRESA LIMA METAL DURO CILÍNDRICA | CORTE AL CENTRO | T LINE
 + CARBIDE ROTARY BURRS | CYLINDRICAL END CUTTING | T LINE

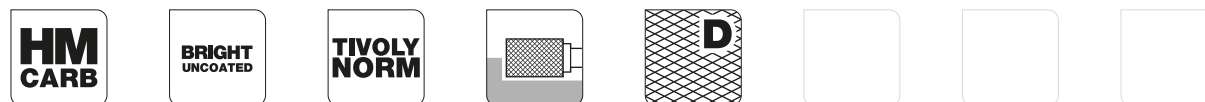
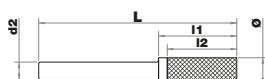

AB Aceros aleados
 200-700 N/mm²
 Alloyed steels
 200-700N/mm²

1037161	Ø	d2	L	I2	QTY	PCB	€
10371610600	6	6	50	16	1	1	12,90
10371610800	8	6	65	20	1	1	17,14
10371611000	10	6	65	20	1	1	20,92
10371611200	12	6	70	25	1	1	26,79

FRESA LIMA METAL DURO | CILÍNDRICA | CORTE AL CENTRO
 + CARBIDE ROTARY BURRS | CYLINDRICAL END CUTTING

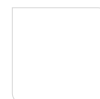
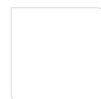
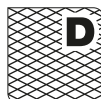
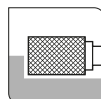
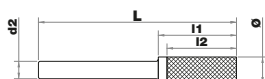

Aceros aleados
200-700 N/mm²
Alloyed steels
200-700N/mm²



Fundiciones
Cast iron



Aleaciones de cobre
Copper alloys

1031631	Ø	d2	L	I2	QTY	PCB	€
10316310400	4	6	50	14	1	1	30,45
10316310600	6	6	50	16	1	1	30,45
10316310800	8	6	65	20	1	1	36,57
10316311000	10	6	65	20	1	1	41,32
10316311200	12	6	70	25	1	1	55,27
10316311600	16	8	70	25	1	1	78,45
103163116006	16	6	70	25	1	1	78,45
10316312000	20	8	70	25	1	1	114,22

FRESA LIMA METAL DURO | CILÍNDRICA | CORTE AL CENTRO
 + CARBIDE ROTARY BURRS | CYLINDRICAL END CUTTING

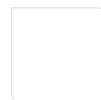
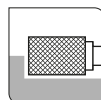

Aleaciones de aluminio
Aluminium alloys

1036651	Ø	d2	L	I2	QTY	PCB	€
10366511000	10	6	70	25	1	1	40,26
10366511200	12	6	70	25	1	1	27,68
10366511600	16	6	70	25	1	1	27,68

FRESADO
MILLING

FRESA LIMA METAL DURO | CILÍNDRICA CON RADIO
 CARBIDE ROTARY BURRS | DOMED CYLINDRICAL

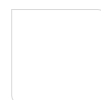
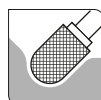
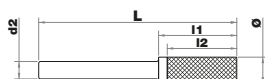

Aceros aleados y tratados
 700-1400 N/mm²
 Heat treatables steels
 700-1400N/mm²

1031641	Ø	d2	L	I2	QTY	PCB	€
10316410400	4	6	50	14	1	1	25,15
10316410600	6	6	50	16	1	1	25,15
10316410800	8	6	65	20	1	1	31,86
10316411000	10	6	65	20	1	1	36,32
10316411200	12	6	70	25	1	1	51,40
10316411600	16	8	70	25	1	1	67,26
103164116006	16	6	70	25	1	1	67,26



Aceros inoxidables
 Stainless Steel

FRESADO MILLING

FRESA LIMA METAL DURO | CILÍNDRICA CON RADIO | T LINE
 CARBIDE ROTARY BURRS | DOMED CYLINDRICAL | T LINE

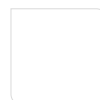
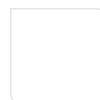
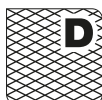
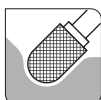
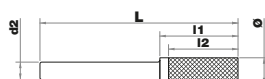

Aceros aleados
 200-700 N/mm²
 Alloyed steels
 200-700N/mm²

1037171	Ø	d2	L	I2	QTY	PCB	€
10371710600	6	6	50	16	1	1	12,90
10371710800	8	6	65	20	1	1	17,14
10371711000	10	6	65	20	1	1	20,92
10371711200	12	6	70	25	1	1	26,79

FRESA LIMA METAL DURO | CILÍNDRICA CON RADIO
 CARBIDE ROTARY BURRS | DOMED CYLINDRICAL

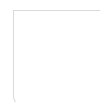
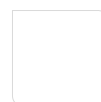
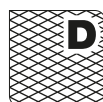
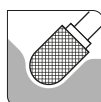
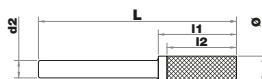

Aceros aleados
200-700 N/mm²
Alloyed steels
200-700N/mm²



Fundiciones
Cast iron



Aleaciones
de cobre
Copper
alloys

1031651	Ø	d2	L	I2	QTY	PCB	€
10316510400	4	6	50	14	1	1	30,15
10316510600	6	6	50	16	1	1	30,15
10316510800	8	6	65	20	1	1	37,71
10316511000	10	6	65	20	1	1	43,28
10316511200	12	6	70	25	1	1	61,70
10316511600	16	8	70	25	1	1	80,69
103165116006	16	6	70	25	1	1	80,69
10316512000	20	8	70	25	1	1	120,91
103165120006	20	6	70	25	1	1	120,91

FRESA LIMA METAL DURO | CILÍNDRICA CON RADIO
 CARBIDE ROTARY BURRS | DOMED CYLINDRICAL

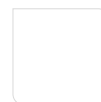
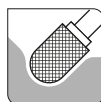
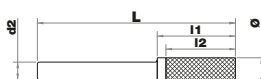

Aleaciones
de aluminio
Aluminium
alloys

1036681	Ø	d2	L	I2	QTY	PCB	€
10366811000	10	6	65	20	1	1	43,28
10366811200	12	6	70	25	1	1	61,70
10366811600	16	6	70	25	1	1	75,41

FRESADO
MILLING



FRESA LIMA METAL DURO | CILÍNDRICA PUNTA CÓNICA

+ CARBIDE ROTARY BURRS | CONE

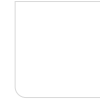
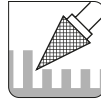
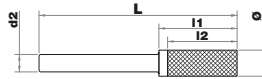

Aceros aleados y tratados
700-1400 N/mm²
Heat treatables steels
700-1400N/mm²



Aceros
inoxidables
Stainless
Steel

1031701	Ø	d2	L	I2	QTY	PCB	€
10317010600	6	6	50	16	1	1	24,89
10317010800	8	6	63	16	1	1	26,26
10317011000	10	6	65	20	1	1	30,45
10317011200	12	6	70	25	1	1	36,87
10317011600	16	8	70	25	1	1	49,69
103170116006	16	6	70	25	1	1	49,69
10317012000	20	8	70	25	1	1	67,26



FRESA LIMA METAL DURO | CILÍNDRICA PUNTA CÓNICA

+ CARBIDE ROTARY BURRS | CONE

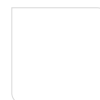
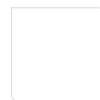
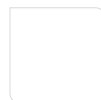
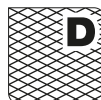
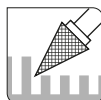
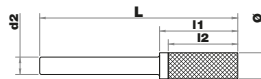

Aceros aleados
200-700 N/mm²
Alloyed steels
200-700N/mm²



Fundiciones
Cast iron



Aleaciones
de cobre
Copper
alloys

1031711	Ø	d2	L	I2	QTY	PCB	€
10317110400	4	6	50	12	1	1	29,91
10317110600	6	6	50	16	1	1	29,91
10317110800	8	6	63	16	1	1	31,57
10317111000	10	6	65	20	1	1	36,32
10317111200	12	6	70	25	1	1	44,14
10317111600	16	8	70	25	1	1	60,60
103171116006	16	6	70	25	1	1	60,60

FRESA LIMA METAL DURO | PUNTA CÓNICA
 CARBIDE ROTARY BURRS | CONE

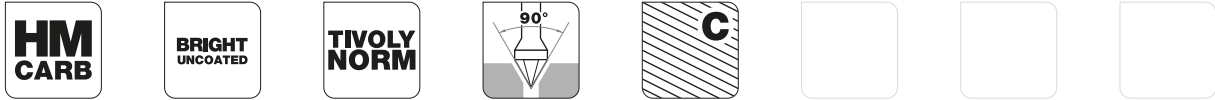
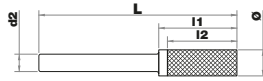

CDE

Aceros aleados y tratados
 700-1400 N/mm²
 Heat treatables steels
 700-1400N/mm²

FGH

Aceros inoxidables
 Stainless Steel

1031721	Ø	d2	L	I2	QTY	PCB	€
10317210400	4	6	50	3	1	1	20,97
10317210600	6	6	50	4	1	1	20,97
10317210800	8	6	52	5	1	1	22,10
10317211000	10	6	55	6	1	1	25,15
10317211200	12	6	58	7	1	1	31,57
103172116006	16	8	61	9	1	1	36,87

FRESA LIMA METAL DURO | PUNTA CÓNICA
 CARBIDE ROTARY BURRS | CONE

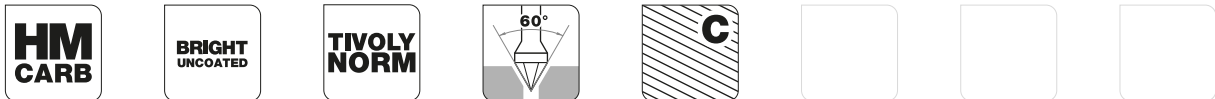
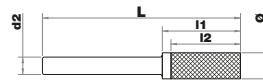

CDE

Aceros aleados y tratados
 700-1400 N/mm²
 Heat treatables steels
 700-1400N/mm²

FGH

Aceros inoxidables
 Stainless Steel

1031741	Ø	d2	L	I2	QTY	PCB	€
10317410400	4	6	50	12	1	1	21,80
10317410600	6	6	50	16	1	1	21,80
10317411000	10	6	65	20	1	1	26,26
10317411200	12	6	70	25	1	1	32,66
103174116006	16	6	70	25	1	1	39,94

FRESADO
MILLING

FRESA LIMA METAL DURO | PUNTA CÓNICA REDONDEADA
 CARBIDE ROTARY BURRS | ROUNDED CONE

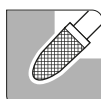

Aceros aleados y tratados
 700-1400 N/mm²
 Heat treatables steels
 700-1400N/mm²

1031761	Ø	d2	L	I2	QTY	PCB	€
10317610600	6	6	50	20	1	1	27,11
10317610800	8	6	65	20	1	1	34,92
10317611000	10	6	65	20	1	1	42,47
10317611200	12	6	70	25	1	1	51,67
10317611600	16	8	75	30	1	1	78,19
103176116006	16	6	70	30	1	1	78,19



Aceros inoxidables
 Stainless Steel

FRESADO MILLING

FRESA LIMA METAL DURO | PUNTA CÓNICA REDONDEADA
 CARBIDE ROTARY BURRS | ROUNDED CONE

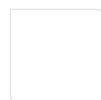
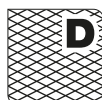
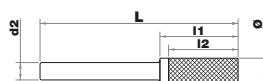

Aceros aleados
 200-700 N/mm²
 Alloyed steels
 200-700N/mm²

1031771	Ø	d2	L	I2	QTY	PCB	€
10317710600	6	6	50	20	1	1	32,36
10317710800	8	6	65	20	1	1	41,61
10317711000	10	6	65	20	1	1	50,81
10317711200	12	6	70	25	1	1	61,70
103177116006	16	6	70	30	1	1	93,53



Fundiciones
 Cast iron



Aleaciones de cobre
 Copper alloys

FRESA LIMA METAL DURO | PUNTA CÓNICA REDONDEADA
 CARBIDE ROTARY BURRS | ROUNDED CONE

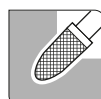

Aleaciones de aluminio
Aluminium alloys

1036701	Ø	d2	L	I2	QTY	PCB	€
10367011000	10	6	65	20	1	1	50,81
10367011200	12	6	70	25	1	1	61,70
10367011600	16	6	70	30	1	1	93,53

FRESA LIMA METAL DURO | PUNTA OJIVA
 CARBIDE ROTARY BURRS | TREE

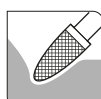
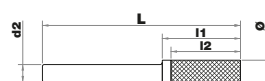
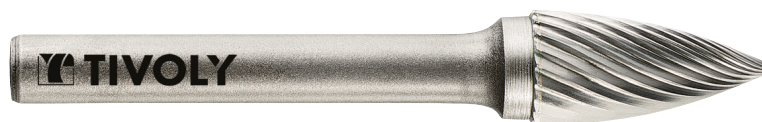

Aceros aleados y tratados
700-1400 N/mm²
Heat treatables steels
700-1400N/mm²

1031781	Ø	d2	L	I2	QTY	PCB	€
10317810400	4	6	50	14	1	1	28,49
10317810600	6	6	50	18	1	1	28,49
10317810800	8	6	63	18	1	1	29,33
10317811000	10	6	65	20	1	1	34,63
10317811200	12	6	70	25	1	1	40,78
10317811600	16	8	75	30	1	1	60,05
103178116006	16	6	75	30	1	1	60,05



Aceros inoxidables
Stainless Steels

FRESADO
MILLING



FRESA LIMA METAL DURO | PUNTA OJIVA | T LINE

✦ CARBIDE ROTARY BURRS | TREE | T LINE

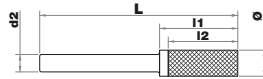

Aceros aleados
200-700 N/mm²
Alloyed steels
200-700N/mm²

1037181	Ø	d2	L	I2	QTY	PCB	€
10371810600	6	6	50	18	1	1	12,90
10371810800	8	6	63	18	1	1	17,14
10371811000	10	6	65	20	1	1	20,92
10371811200	12	6	70	25	1	1	26,79



FRESA LIMA METAL DURO | PUNTA OJIVA

✦ CARBIDE ROTARY BURRS | TREE

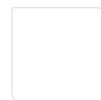
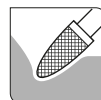
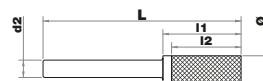

Aceros aleados
200-700 N/mm²
Alloyed steels
200-700N/mm²



Fundiciones
Cast iron



Aleaciones
de cobre
Copper
alloys

1031791	Ø	d2	L	I2	QTY	PCB	€
10317910600	6	6	50	18	1	1	34,33
10317910800	8	6	63	18	1	1	35,20
10317911000	10	6	65	20	1	1	41,61
10317911200	12	6	70	25	1	1	48,90
10317911600	16	8	75	30	1	1	72,34
103179116006	16	6	75	30	1	1	72,34

FRESA LIMA METAL DURO | PUNTA OVAL
 CARBIDE ROTARY BURRS | OVAL

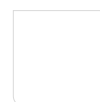
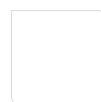
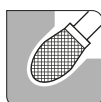
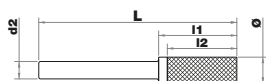

Aceros aleados y tratados
 700-1400 N/mm²
 Heat treatables steels
 700-1400N/mm²

1031801	Ø	d2	L	I2	QTY	PCB	€
10318010600	6	6	50	10	1	1	25,99
10318010800	8	6	58	13	1	1	28,78
10318011000	10	6	61	16	1	1	34,63
10318011200	12	6	65	20	1	1	41,61
10318011600	16	8	70	25	1	1	60,05
103180116006	16	6	70	25	1	1	60,05



Aceros inoxidables
 Stainless Steel

FRESA LIMA METAL DURO | PUNTA OVAL
 CARBIDE ROTARY BURRS | OVAL

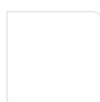
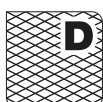
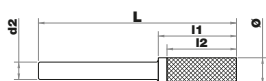

Aceros aleados
 200-700 N/mm²
 Alloyed steels
 200-700N/mm²

1031811	Ø	d2	L	I2	QTY	PCB	€
10318110400	4	6	50	6	1	1	31,28
10318110600	6	6	50	10	1	1	31,28
10318110800	8	6	58	13	1	1	34,63
10318111000	10	6	61	16	1	1	41,61
10318111200	12	6	65	20	1	1	49,69
10318111600	16	8	70	25	1	1	72,34
103181116006	16	6	70	25	1	1	72,34
10318112000	20	8	70	25	1	1	114,22
103181120006	20	6	70	25	1	1	114,22



Fundiciones
 Cast iron



Aleaciones de cobre
 Copper alloys

FRESADO
MILLING



FRESA LIMA METAL DURO | PUNTA OJIVA REDONDEADA

CARBIDE ROTARY BURRS | BALL NOSED TREE

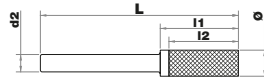

Aceros aleados y tratados
700-1400 N/mm²
Heat treatables steels
700-1400N/mm²

1031821	Ø	d2	L	I2	QTY	PCB	€
10318210600	6	6	50	18	1	1	29,60
10318210800	8	6	63	18	1	1	31,00
10318211000	10	6	65	20	1	1	36,87
10318211200	12	6	70	25	1	1	44,14
10318211600	16	8	75	30	1	1	63,10
103182116006	16	6	75	30	1	1	63,10



Aceros inoxidables
Stainless Steel



FRESA LIMA METAL DURO | PUNTA OJIVA REDONDEADA | T LINE

CARBIDE ROTARY BURRS | BALL NOSED TREE | T LINE

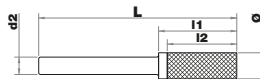

Aceros aleados
200-700 N/mm²
Alloyed steels
200-700N/mm²

1037191	Ø	d2	L	I2	QTY	PCB	€
10371910600	6	6	50	18	1	1	12,90
10371910800	8	6	63	18	1	1	17,14
10371911000	10	6	65	20	1	1	20,92
10371911200	12	6	70	25	1	1	26,79

FRESA LIMA METAL DURO | PUNTA OJIVA REDONDEADA
 + CARBIDE ROTARY BURRS | BALL NOSED TREE

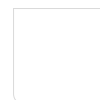
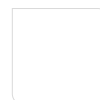
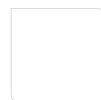
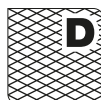

Fundiciones
Cast iron



Aleaciones de cobre
Copper alloys

1031831	Ø	d2	L	I2	QTY	PCB	€
10318310600	6	6	50	18	1	1	35,73
10318310800	8	6	63	18	1	1	37,14
10318311000	10	6	65	20	1	1	44,14
10318311200	12	6	70	25	1	1	52,77
10318311600	16	8	75	30	1	1	75,41
103183116006	16	6	75	30	1	1	75,41
10318312000	20	8	75	30	1	1	140,17
103183120006	20	6	75	30	1	1	140,17

FRESA LIMA METAL DURO | PUNTA OJIVA REDONDEADA
 + CARBIDE ROTARY BURRS | BALL NOSED TREE

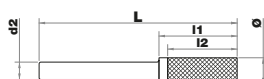

Aleaciones de aluminio
Aluminium alloys

1036671	Ø	d2	L	I2	QTY	PCB	€
10366711000	10	6	65	20	1	1	44,59
10366711200	12	6	70	25	1	1	52,77
10366711600	16	6	75	30	1	1	75,41

FRESADO
MILLING

FRESA LIMA METAL DURO | PUNTA ESFÉRICA
 CARBIDE ROTARY BURRS | BALL

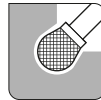
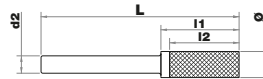

Aceros aleados y tratados
 700-1400 N/mm²
 Heat treatables steels
 700-1400N/mm²



Aceros inoxidables
 Stainless Steel

1031841	Ø	d2	L	I2	QTY	PCB	€
10318410400	4	6	50	18	1	1	25,15
10318410600	6	6	50	18	1	1	25,15
10318410800	8	6	63	18	1	1	26,26
10318411000	10	6	65	20	1	1	30,43
10318411200	12	6	70	25	1	1	36,87
10318411600	16	8	75	30	1	1	52,49
103184116006	16	6	75	30	1	1	52,49
103184120006	20	6	75	30	1	1	83,76

FRESA LIMA MD PUNTA ESFÉRICA | T LINE
 CARBIDE ROTARY BURRS | BALL | T LINE

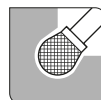

Aceros aleados
 200-700 N/mm²
 Alloyed steels
 200-700N/mm²

1037201	Ø	d2	L	I2	QTY	PCB	€
10372010600	6	6	50	18	1	1	12,90
10372010800	8	6	63	18	1	1	17,14
10372011000	10	6	65	20	1	1	20,92
10372011200	12	6	70	25	1	1	26,79



FRESA LIMA METAL DURO | PUNTA ESFÉRICA

CARBIDE ROTARY BURRS | BALL

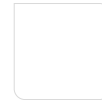
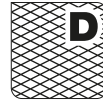
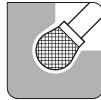
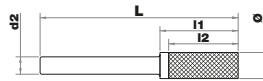

Aceros aleados
200-700 N/mm²
Alloyed steels
200-700N/mm²



Fundiciones
Cast iron



Aleaciones
de cobre
Copper
alloys

1031851	Ø	d2	L	I2	QTY	PCB	€
10318510400	4	6	50	18	1	1	30,15
10318510600	6	6	50	18	1	1	30,15
10318510800	8	6	63	18	1	1	31,57
10318511000	10	6	65	20	1	1	36,57
10318511200	12	6	70	25	1	1	44,14
103185116006	16	6	75	30	1	1	62,84
10318512000	20	8	75	30	1	1	100,50
103185120006	20	6	75	30	1	1	100,50



FRESA LIMA MD PUNTA ESFÉRICA

CARBIDE ROTARY BURRS | BALL

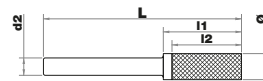

Aleaciones
de aluminio
Aluminium
alloys

1036691	Ø	d2	L	I2	QTY	PCB	€
10366911000	10	6	65	20	1	1	36,59
10366911200	12	6	70	25	1	1	44,14



**ESTUCHE | FLK08 | 5 FRESAS ROTATIVAS METAL DURO |
Ø 8 MANGO DE 6 mm**

SET | FLK08 | 5 ROTARY BURRS CARBIDE | Ø 8 SHANK 6 mm



**05
PCS**

**HM
CARB**

**BRIGHT
UNCOATED**

**Ø
8
mm**

**CYL
6mm**

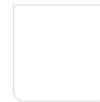

10316070008

QTY	PCB	€
5	1	88,81



**ESTUCHE | FLK05 | 5 FRESAS ROTATIVAS METAL DURO |
Ø 12 MANGO DE 6 mm**

SET | FLK05 | 5 ROTARY BURRS CARBIDE | Ø 12 SHANK 6 mm



**05
PCS**

**HM
CARB**

**BRIGHT
UNCOATED**

**Ø
8
mm**

**CYL
6mm**

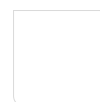

10316070002

QTY	PCB	€
5	1	225,95



FRESA FRONTAL ACABADO 1Z | ACERO COBALTO 8% (HSSE8) | APLICACIÓN: ALUMINIO

1Z FINISHING END MILL COBALT SEEL 8% (HSSE8) | APPLICATION: ALUMINIUM

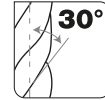
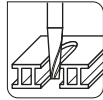
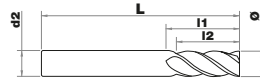

Aleaciones de aluminio dúctil
Fat aluminium alloys



Aleaciones de aluminio Si<10%
Aluminium alloys Si<10%



Aleaciones de aluminio Si>10%
Aluminium alloys Si>10%

8030881	Ø	d2	L	I2	QTY	PCB	€
80308810406	4	8	60	12	1	1	29,66
80308810506	5	8	60	14	1	1	29,66
80308810508	5	8	80	14	1	1	29,66
80308810512	5	8	120	14	1	1	36,98
80308810606	6	8	60	14	1	1	32,92
80308810706	7	8	60	14	1	1	34,28
80308810808	8	8	80	14	1	1	31,88
80308810813	8	8	130	14	1	1	37,22
80308811008	10	8	80	14	1	1	38,76
80308811013	10	10	130	17	1	1	38,68



FRESA FRONTAL ACABADO 2Z | ACERO COBALTO 8% (HSSE8) | DIN 327D

2Z FINISHING END MILL COBALT STEEL 8% (HSSE8) | DIN 327D

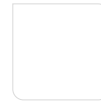
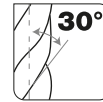
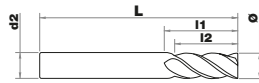
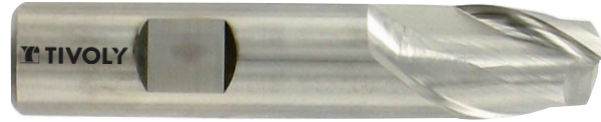

Aceros aleados
200-700 N/mm²
Alloyed steels
200-700N/mm²



Aceros aleados
y tratados
700-1200 N/mm²
Heat treatables steels
700-1200N/mm²



Aceros
inoxidables
Stainless
Steels



Fundiciones
Cast iron



Aleaciones
de cobre
Copper
alloys

8030031	Ø	d2	L	I2	QTY	PCB	€
80300310100	1	6	47	2.5	1	1	19,22
80300310150	1.5	6	47	3	1	1	19,54
80300310200	2	6	48	4	1	1	17,16
80300310250	2.5	6	49	5	1	1	17,16
80300310300	3	6	49	5	1	1	17,16
80300310350	3.5	6	50	6	1	1	18,06
80300310400	4	6	51	7	1	1	17,16
80300310450	4.5	6	51	7	1	1	19,32
80300310500	5	6	52	8	1	1	17,16
80300310550	5.5	6	52	8	1	1	20,27
80300310600	6	6	52	8	1	1	17,16
80300310650	6.5	10	60	10	1	1	26,79
80300310700	7	10	60	10	1	1	25,86
80300310750	7.5	10	60	10	1	1	25,86
80300310800	8	10	61	11	1	1	22,13
80300310850	8.5	10	61	11	1	1	28,67
80300310900	9	10	61	11	1	1	25,57
80300310950	9.5	10	61	11	1	1	25,24
80300311000	10	10	63	13	1	1	24,31
80300311100	11	12	70	13	1	1	28,47
80300311200	12	12	73	16	1	1	26,84
80300311300	13	12	73	16	1	1	35,72
80300311400	14	12	73	16	1	1	33,36
80300311500	15	12	73	16	1	1	38,34
80300311600	16	16	79	19	1	1	38,08
80300311700	17	16	79	19	1	1	50,51
80300311800	18	16	79	19	1	1	46,04
80300311900	19	16	79	19	1	1	68,07
80300312000	20	20	88	22	1	1	63,22
80300312200	22	20	88	22	1	1	80,67
80300312400	24	25	102	26	1	1	113,35
80300312800	28	25	102	26	1	1	142,28
80300313000	30	25	102	26	1	1	157,79
80300313200	32	32	112	32	1	1	171,23
80300313600	36	32	112	32	1	1	193,66
80300314000	40	40	130	38	1	1	246,48



FRESA FRONTAL ACABADO 3Z | ACERO COBALTO 8% (HSSE8) | DIN 844B | TIALN

3Z FINISHING END MILL COBALT STEEL 8% (HSSE8) | DIN 844B | TIALN

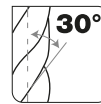
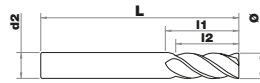
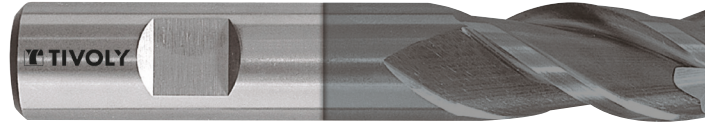

Aceros aleados
200-700 N/mm²
Alloyed steels
200-700N/mm²



Aceros aleados
y tratados
700-1200 N/mm²
Heat treatables steels
700-1200N/mm²



Aceros
inoxidables
Stainless
Steels



Fundiciones
Cast iron



Aleaciones
de cobre
Copper
alloys

8037131	Ø	d2	L	I2	QTY	PCB	€
80371310400	4	6	55	11	1	1	11,60
80371310500	5	6	57	13	1	1	11,60
80371310600	6	6	57	13	1	1	11,60
80371310800	8	10	69	19	1	1	18,86
80371311000	10	10	72	22	1	1	18,86
80371311200	12	12	83	26	1	1	26,12
80371311600	16	16	92	32	1	1	36,27
80371312000	20	20	104	38	1	1	56,60



FRESA FRONTAL ACABADO 3Z | ACERO COBALTO 8% (HSSE8) | DIN 327D

3Z FINISHING END MILL COBALT STEEL 8% (HSSE8) | DIN 327D

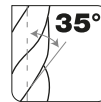
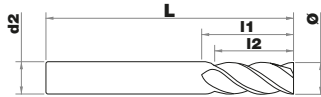

Aceros aleados
200-700 N/mm²
Alloyed steels
200-700N/mm²



Aceros aleados
y tratados
700-1200 N/mm²
Heat treatables steels
700-1200N/mm²



Aceros
inoxidables
Stainless
Steels

8030111	Ø	d2	L	I2	QTY	PCB	€
80301110200	2	6	48	4	1	1	19,40
80301110300	3	6	49	5	1	1	19,80
80301110400	4	6	51	7	1	1	20,05
80301110500	5	6	52	8	1	1	20,05
80301110600	6	10	60	10	1	1	20,05
80301110800	8	10	61	11	1	1	26,65
80301111000	10	10	63	13	1	1	24,85
80301111200	12	12	73	16	1	1	30,16
80301111400	14	12	73	16	1	1	39,09
80301111600	16	16	79	19	1	1	46,08
80301111800	18	16	79	19	1	1	55,56
80301112000	20	20	88	22	1	1	65,04
80301112200	22	20	88	22	1	1	100,23
80301112400	24	25	102	26	1	1	137,05
80301112800	28	25	102	26	1	1	173,88
80301113000	30	25	102	26	1	1	182,39



FRESA FRONTAL ACABADO 4Z | ACERO COBALTO 8% (HSSE8) | DIN 844B

+ 4Z FINISHING END MILL COBALT STEEL 8% (HSSE8) | DIN 844B

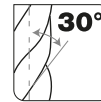
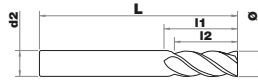
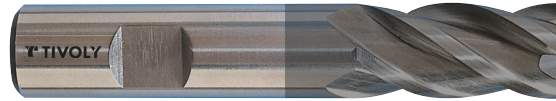

Aceros aleados
200-700 N/mm²
Alloyed steels
200-700N/mm²



Aceros aleados
y tratados
700-1200 N/mm²
Heat treatables steels
700-1200N/mm²



Aceros
inoxidables
Stainless
Steels



Fundiciones
Cast iron



Aleaciones
de cobre
Copper
alloys

8037141	Ø	d2	L	I2	QTY	PCB	€
80371410400	4	6	55	11	1	1	11,60
80371410500	5	6	57	13	1	1	11,60
80371410600	6	6	57	13	1	1	11,60
80371410800	8	10	69	19	1	1	18,86
80371411000	10	10	72	22	1	1	18,86
80371411200	12	12	83	26	1	1	26,12
80371411600	16	16	92	32	1	1	36,27
80371412000	20	20	104	38	1	1	56,60



FRESA FRONTAL ACABADO 3-6Z | ACERO COBALTO 8% (HSSE8) | DIN 844B

3-6Z FINISHING END MILL COBALT STEEL 8% (HSSE8) | DIN 844B

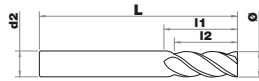
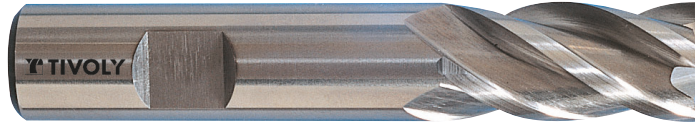

Aceros aleados
200-700 N/mm²
Alloyed steels
200-700N/mm²



Aceros aleados
y tratados
700-1200 N/mm²
Heat treatables steels
700-1200N/mm²



Aceros
inoxidables
Stainless
Steels



Fundiciones
Cast iron



Aleaciones
de cobre
Copper
alloys

8030191	Ø	d2	L	I2	Z	QTY	PCB	€
80301910200	2	6	51	7	3	1	1	19,01
80301910250	2.5	6	52	8	3	1	1	19,32
80301910300	3	6	52	8	3	1	1	17,16
80301910350	3.5	6	54	10	3	1	1	18,06
80301910400	4	6	55	11	4	1	1	16,51
80301910450	4.5	6	55	11	4	1	1	17,16
80301910500	5	6	57	13	4	1	1	16,51
80301910600	6	6	57	13	4	1	1	17,16
80301910700	7	10	66	16	4	1	1	26,31
80301910800	8	10	69	19	4	1	1	19,96
80301910900	9	10	69	19	4	1	1	26,55
80301911000	10	10	72	22	4	1	1	22,22
80301911200	12	12	83	26	4	1	1	30,41
80301911400	14	12	83	26	4	1	1	38,87
80301911500	15	12	83	26	4	1	1	46,55
80301911600	16	16	92	32	4	1	1	42,33
80301911800	18	16	92	32	4	1	1	56,58
80301912000	20	20	104	38	4	1	1	59,48
80301912200	22	20	104	38	4	1	1	94,98
80301912500	25	25	121	45	6	1	1	123,91
80301912800	28	25	121	45	6	1	1	155,39
80301913000	30	25	121	45	6	1	1	161,70
80301913200	32	32	133	53	6	1	1	177,10



FRESA FRONTAL DESBASTE | ACERO COBALTO 8% (HSSE8) | DIN 844B | TIALN

4Z FINISHING END MILL COBALT STEEL 8% (HSSE8) | DIN 844B | TIALN

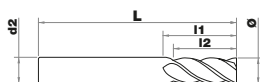

Aceros aleados
200-700 N/mm²
Alloyed steels
200-700N/mm²



Aceros aleados
y tratados
700-1200 N/mm²
Heat treatables steels
700-1200N/mm²



Aceros
inoxidables
Stainless
Steels



Fundiciones
Cast iron

8037151	Ø	d2	L	l2	QTY	PCB	€
80371510600	6	6	57	13	1	1	26,12
80371510800	8	10	69	19	1	1	27,56
80371511000	10	10	72	22	1	1	27,56
80371511200	12	12	83	26	1	1	34,82
80371511600	16	16	92	32	1	1	47,87
80371512000	20	20	104	38	1	1	71,09





AFILADORES
SHARPENING

CATÁLOGO GENERAL
2021

■ **DRILL DOCTOR &
ACCESORIOS**
DRILL DOCTOR &
ACCESORIES

214

DRILL DOCTOR 750 Ø 2,5>19 mm | 118°>135° PUNTA CONVENCIONAL Y SPLIT POINT

DRILL DOCTOR 750 Ø 2,5>19 mm | 118°>135° CONVENTIAL AND SPLIT POINT

**DD
750**



111177750M		
QTY	PCB	€
1	1	427,41

DRILL DOCTOR 500 Ø 2,5>13 mm | 118°>135° PUNTA CONVENCIONAL Y SPLIT POINT

DRILL DOCTOR 500 Ø 2,5>13 mm | 118°>135° CONVENTIAL AND SPLIT POINT

**DD
500**



111177500M		
QTY	PCB	€
1	1	346,10

DRILL DOCTOR 400 Ø 2,5>13 mm | 118° PUNTA CONVENCIONAL Y SPLIT POINT

DRILL DOCTOR 400 Ø 2,5>13 mm | 118° CONVENTIAL AND SPLIT POINT

**DD
400**



111177400B		
QTY	PCB	€
1	1	167,05

MUELA PARA DRILL DOCTOR 400, 500, 750 GR. 100
 DRILL DOCTOR 400, 500, 750 GRINDER, GRIT 100



M
100

1111720004		
QTY	PCB	€
1	1	74,07

MUELA PARA DRILL DOCTOR 400, 500, 750 GR. 180
 DRILL DOCTOR 400, 500, 750 GRINDER, GRIT 180



M
180

1111720001		
QTY	PCB	€
1	1	64,03

PORTABROCAS PARA DRILL DOCTOR 400, 500, 750 RANGO Ø 2,5>19 mm
 DRILL DOCTOR 400, 500, 750 CHUCK Ø 2,5>19 mm



Ø
2,5-19
mm

1111720002		
QTY	PCB	€
1	1	126,26

AFILADORES
SHARPENING

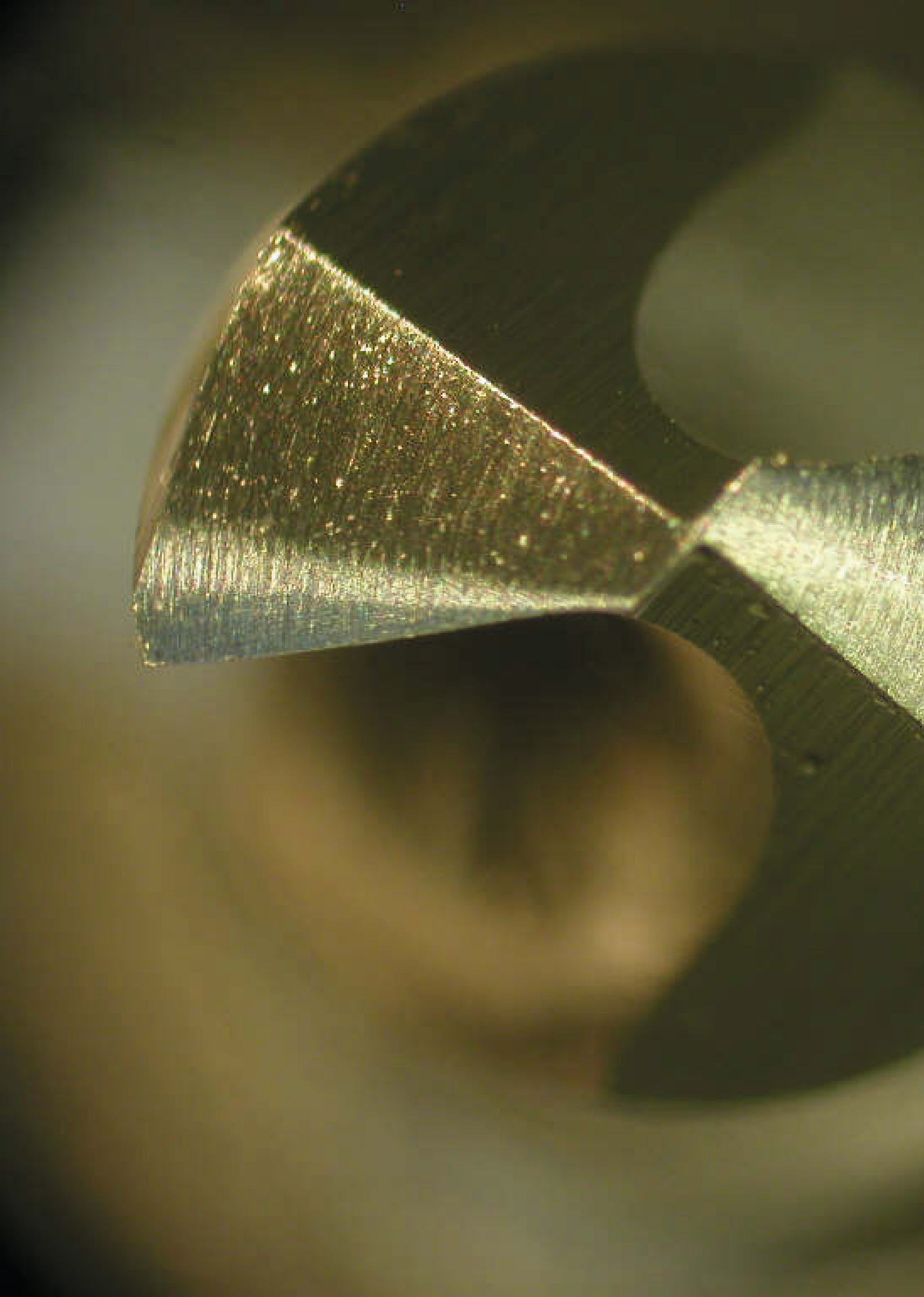

- **INFORMACIÓN TÉCNICA 218**
TECHNICAL INFORMATION

- **CONDICIONES DE CORTE
ROSCADO 219**
CUTTING CONDITIONS
TAPPING

- **CONDICIONES DE CORTE 224**
BROCAS
CUTTING CONDITIONS
DRILLS

- **CONDICIONES DE CORTE 226**
MACHOS
CUTTING CONDITIONS
TAPS

- **CONDICIONES DE CORTE 228**
FRESAS LIMAS
CUTTING CONDITIONS
ROTARY BURRS

- **CONDICIONES DE CORTE 230**
FRESADO
CUTTING CONDITIONS END
MILLING

- **CONDICIONES DE VENTA 234**
CONDITIONS OF SALE

INFORMACIONES TÉCNICAS | TECHNICAL INFORMATION

N	$\frac{V_c \times 1000}{\phi \times \pi}$	Velocidad de giro Revolution per minute
V_c	$\frac{\phi \times \pi \times N}{1000}$	Velocidad de corte Cutting speed
F_z	$\frac{V_f}{Z \times N}$	Avance por diente Fed per tooth
F	$F_z \times Z$	Avance por vuelta Feed per revolution
V_f	$F_z \times Z \times N$	Velocidad de avance Feed speed

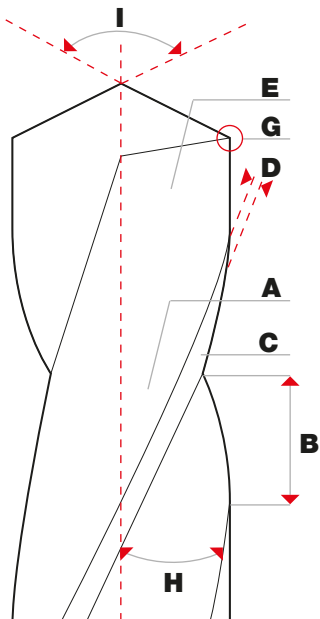

- A. Canal** | Flute
- B. Labio** | Lip
- C. Faja guía** | Margin
- D. Ancho de la faja guía** | Margin Width
- E. Superficie destalonada** | Relief
- F. Nucleo** | Web
- G. Punta externa** | Corner
- H. Angulo de la helice** | Helix Angle
- I. Angulo de la punta** | Point Angle
- J. Angulo de incidencia de la artista principal** | Lip relief angle
- K. Angulo del filo transversal** | Chisel edge angle

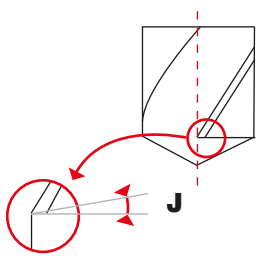
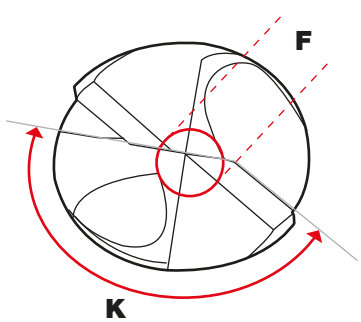

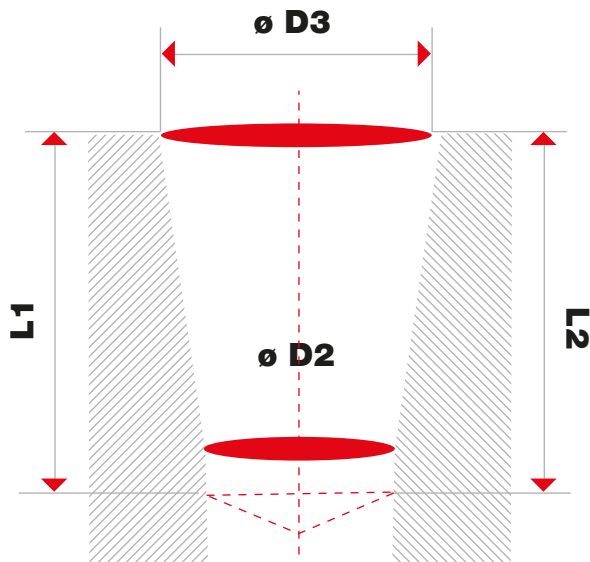

CONDICIONES DE CORTE | CUTTING CONDITIONS

ROSCADO TAPPING

RC (Conical)				
ø	P	D2	D3	L1 MMIN.
RC 1/16	28	6	6,5	10,1
RC 1/8	28	8	8,5	10,1
RC 1/4	19	10,7	11,35	15
RC 3/8	19	14,15	14,85	15,4
RC 1/2	14	17,6	18,5	20,5
RC 3/4	14	23	24	21,8
RC 1	11	29	30,2	26
RC 1,1/4	11	37,5	38,8	28,3
RC 1,1/2	11	43,35	44,7	28,3
RC 2	11	54,9	56,5	32,7

NPT (Conical)				
ø	P	D2	D3	L1 MMIN.
NPT 1/16	27	6	6,41	12
NPT 1/8	27	8,3	8,76	12
NPT 1/4	18	10,7	11,4	17,5
NPT 3/8	18	14,2	14,84	17,6
NPT 1/2	14	17,4	18,33	22,8
NPT 3/4	14	22,8	23,68	23
NPT 1	11,5	28,6	29,72	27,4
NPT 1,1/4	11,5	37,4	38,48	28,1
NPT 1,1/2	11,5	43,4	44,55	28,4
NPT 2	11,5	55,5	56,59	28

NPTF (Conical)				
ø	P	D2	D3	L1 MMIN.
NPTF 1/16	27	6	6,41	12
NPTF 1/8	27	8,3	8,76	12
NPTF 1/4	18	10,7	11,4	17,5
NPTF 3/8	18	14,2	14,84	17,6
NPTF 1/2	14	17,4	18,33	22,8
NPTF 3/4	14	22,8	23,68	23
NPTF 1	11,5	28,6	29,72	27,4
NPTF 1,1/4	11,5	37,4	38,48	28,1
NPTF 1,1/2	11,5	43,4	44,55	28,4
NPTF 2	11,5	55,5	56,59	28

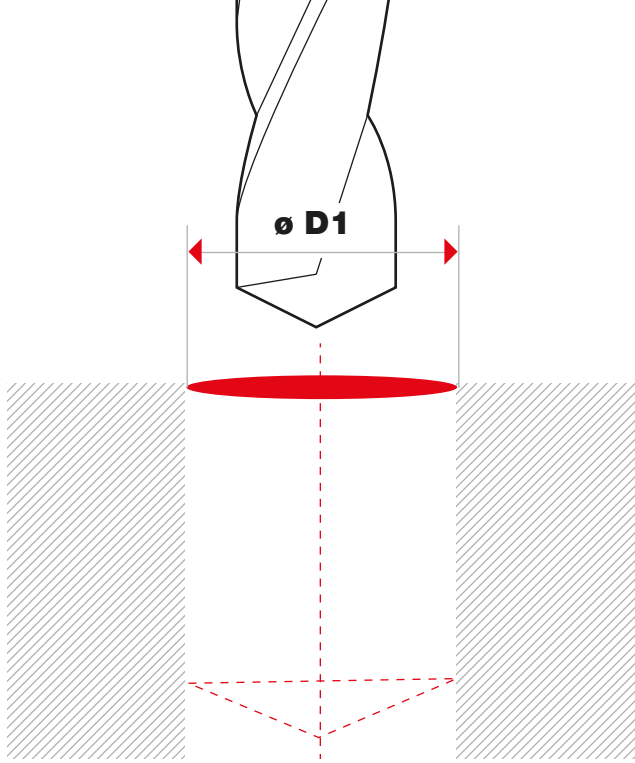

DIÁMETROS PREVIOS | PREVIOUS HOLE AL ROSCADO TAPPING

M		
\varnothing	P	PRE-HOLE (mm)

M 1	0,25	0,75
M 1,1	0,25	0,85
M 1,2	0,25	0,95
M 1,4	0,3	1,1
M 1,6	0,35	1,25
M 1,7	0,35	-
M 1,8	0,35	1,45
M 2	0,4	1,6
M 2,2	0,45	1,75
M 2,3	0,4	-
M 2,5	0,45	2,05
M 2,6	0,45	-
M 3	0,5	2,5
M 3,5	0,6	2,9
M 4	0,7	3,3
M 4,5	0,75	3,7
M 5	0,8	4,2
M 5,5	0,9	-
M 6	1	5
M 7	1	6
M 8	1,25	6,8
M 9	1,25	7,8
M 10	1,5	8,5
M 11	1,5	9,5
M 12	1,75	10,2
M 14	2	12
M 16	2	14
M 18	2,5	15,5
M 20	2,5	17,5
M 22	2,5	19,5
M 24	3	21
M 27	3	24
M 30	3,5	26,5
M 33	3,5	29,5
M 36	4	32
M 39	4	35
M 42	4,5	37,5
M 45	4,5	40,5
M 48	5	43
M 52	5	47
M 56	5,5	50,5
M 60	5,5	54,5
M 64	6	58
M 68	6	62

MF		
\varnothing	P	PRE-HOLE (mm)

MF 2	0,25	1,75
MF 2,2	0,25	1,95
MF 2,25	0,25	2
MF 3	0,35	2,65
MF 3,5	0,35	3,15
MF 4	0,5	3,5
MF 4,5	0,5	4
MF 5	0,5	4,5
MF 6	0,5	5,5
MF 6	0,75	5,2
MF 8	0,75	7,2
MF 10	0,75	9,2
MF 8	1	7
MF 10	1	9
MF 12	1	11
MF 16	1	15
MF 20	1	19
MF 10	1,25	8,8
MF 14	1,25	12,8
MF 12	1,5	10,5
MF 16	1,5	14,5
MF 20	1,5	18,5
MF 24	1,5	22,5
MF 36	1,5	34,5
MF 48	1,5	46,5
MF 56	1,5	54,5
MF 20	2	18
MF 30	2	28
MF 42	2	40
MF 56	2	54
MF 36	3	33
MF 48	3	45
MF 56	3	53
MF 64	3	61
MF 48	4	44
MF 56	4	52
MF 64	4	60
MF 72	4	68
MF 80	6	74
MF 95	6	89
MF 110	6	104

BSW		
\varnothing	P	PRE-HOLE (mm)

BSW (1/16)	60	1,15
BSW (3/32)	48	1,85
BSW (1/8)	40	2,55
BSW (5/32)	32	3,2
BSW (3/16)	24	3,7
BSW (7/32)	24	4,5
BSW 1/4	20	5,1
BSW 5/16	18	6,5
BSW 3/8	16	7,9
BSW 7/16	14	9,25
BSW 1/2	12	10,5
BSW 9/16	12	12
BSW 5/8	11	13,5
BSW 3/4	10	16,5
BSW 7/8	9	19,25
BSW 1"	8	22
BSW 1,1/8	7	24,75
BSW 1,1/4	7	27,75
BSW 1,3/8	6	30,5
BSW 1,1/2	6	33,5
BSW 1,5/8	5	35,5
BSW 1,3/4	5	39
BSW 1,7/8	4,1/2	41,5
BSW 2"	4,1/2	44,5
BSW 2,1/4	4	50
BSW 2,1/2	4	56,5
BSW 2,3/4	3,1/2	62
BSW 3"	2,1/2	68

BSF		
\varnothing	P	PRE-HOLE (mm)

BSF 3/16	32	4
BSF 7/32	28	4,6
BSF 1,4	26	5,3
BSF 9/32	26	60,1
BSF 5/16	22	6,8
BSF 3/8	20	8,3
BSF 7/16	18	9,7
BSF 1/2	16	11,1
BSF 9/16	16	12,7
BSF 5/8	14	14
BSF 11/16	14	15,5
BSF 3/4	12	16,75
BSF (13/16)	12	18,5
BSF 7/8	11	19,75
BSF 1"	10	22,75
BSF 1,1/8	9	25,5
BSF 1,3/8	8	31,5
BSF 1,1/2	8	34,8
BSF 1,5/8	8	38
BSF 1,3/4	7	40,5
BSF 2"	7	47
BSF 2,1/4	6	52,5
BSF 2,1/2	6	50
BSF 2,3/4	6	65,4
BSF 3"	5	70,5

BSPG		
Ø	P	PRE-HOLE (mm)

BSPG 1/8	28	8,8
BSPG 1/4	19	11,8
BSPG 3/8	19	15,25
BSPG 1/2	14	19
BSPG 5/8	14	21
BSPG 3/4	14	24,5
BSPG 7/8	14	28,25
BSPG 1"	11	30,75
BSPG 1,1/8	11	35,5
BSPG 1,1/4	11	39,5
BSPG (1,3/8)	11	42
BSPG 1,1/2	11	45,5
BSPG (1,5/8)	11	49,6
BSPG 1,3/4	11	51,4
BSPG 2"	11	57,2
BSPG 2,1/4	11	63,3
BSPG (2,3/8)	11	67
BSPG (2,1/2)	11	72,8
BSPG 2,3/4	11	79,1
BSPG 3"	11	85,5
BSPG 3,1/4	11	91,5
BSPG 3,1/2	11	98
BSPG 3,3/4	11	104
BSPG 4"	11	110,5

UNC		
Ø	P	PRE-HOLE (mm)

UNC 1	64	1,5
UNC 2	56	1,8
UNC 3	48	2,1
UNC 4	40	2,3
UNC 5	40	2,6
UNC 6	32	2,85
UNC 8	32	3,5
UNC 10	24	3,9
UNC 12	24	4,5
UNC 1/4	20	5,2
UNC 5/16	18	6,6
UNC 3/8	16	8
UNC 7/16	14	9,4
UNC 1/2	13	10,75
UNC 9/16	12	12,26
UNC 5/8	11	13,5
UNC 3/4	10	16,5
UNC 7/8	9	19,5
UNC 1"	8	22,25
UNC 1,1/8	7	25
UNC 1,1/4	7	28,25
UNC 1,3/8	6	30,75
UNC 1,1/2	6	34
UNC 1,3/4	5	39,5
UNC 2"	4,1/2	45
UNC 2,1/4	4,1/2	51,5
UNC 2,1/2	4	57,5
UNC 2,3/4	4	63,5
UNC 3"	4	70

UNF		
Ø	P	PRE-HOLE (mm)

UNF 0	80	1,25
UNF 1	72	1,55
UNF 2	64	1,85
UNF 3	56	2,1
UNF 4	48	2,4
UNF 5	44	2,75
UNF 6	40	3
UNF 8	36	3,5
UNF 10	32	4,1
UNF 12	28	4,65
UNF 1/4	28	5,5
UNF 5/16	24	6,9
UNF 3/8	20	8,5
UNF 7/16	20	9,9
UNF 1/2	20	11,5
UNF 9/16	18	12,9
UNF 5/8	18	14,5
UNF 3/4	16	17,5
UNF 7/8	14	20,5
UNF 1"	12	23,25
UNF 1,1/8	12	26,5
UNF 1,1/4	12	29,75
UNF 1,3/8	12	32,75
UNF 1,1/2	12	36

PG		
Ø	-	PRE-HOLE (mm)

PG 7	-	11,4
PG 9	-	14
PG 11	-	17,25
PG 13,5	-	19
PG 16	-	21,25
PG 21	-	26,75
PG 29	-	35,5
PG 36	-	45,5
PG 42	-	62,6
PG 48	-	57,7

RC			
Ø	P	PRE-HOLE (mm)	L1 MMIN.

RC 1/16	28	6,3	10,1
RC 1/8	28	8,3	10,1
RC 1/4	19	11	15
RC 3/8	19	14,5	15,4
RC 1/2	14	18,1	20,5
RC 3/4	14	23,5	21,8
RC 1	11	29,6	26
RC 1,1/4	11	38,1	28,3
RC 1,1/2	11	44	28,3
RC 2	11	55,6	32,7

NPT			
Ø	P	PRE-HOLE (mm)	L1 MMIN.

NPT 1/16	27	6,2	12
NPT 1/8	27	8,5	12
NPT 1/4	18	11	17,5
NPT 3/8	18	14,5	17,6
NPT 1/2	14	17,8	22,8
NPT 3/4	14	23	23
NPT 1	11,5	29	27,4
NPT 1,1/4	11,5	37,5	28,1
NPT 1,1/2	11,5	44	28,4
NPT 2	11,5	56	28

NPTF			
Ø	P	PRE-HOLE (mm)	L1 MMIN.

NPTF 1/16	27	6,2	12
NPTF 1/8	27	8,5	12
NPTF 1/4	18	11	17,5
NPTF 3/8	18	14,5	17,6
NPTF 1/2	14	17,8	22,8
NPTF 3/4	14	23	23
NPTF 1	11,5	29	27,4
NPTF 1,1/4	11,5	37,5	28,1
NPTF 1,1/2	11,5	44	28,4
NPTF 2	11,5	56	28

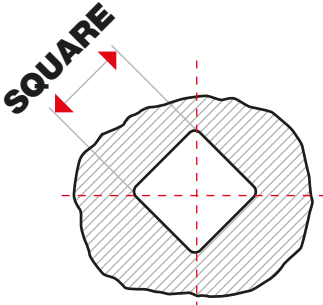
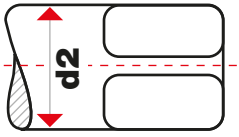

DIMENSIONES DE MANGO | SHANK DIMENSIONS

ROSCADO TAPPING

SQUARE ISO 529

o	P	d2	SQUARE
M2	0,4	2,5	2
M2,5	0,45	2,8	2,24
M3	0,5	3,15	2,5
M3,5	0,6	3,55	2,8
M4	0,7	4	3,15
M4	0,75	4	3,15
M5	0,8	5	4
M5	0,9	5	4
M6	1	6,3	5
M7	1	7,1	5,6
M8	1,25	8	6,3
M9	1,25	8	6,3
M10	1,5	10	8
M11	1,5	8	6,3
M12	1,75	9	7,1
M14	2	11,2	9
M16	2	12,5	10
M18	2,5	14	11,2
M20	2,5	14	11,2
M22	2,5	16	12,5
M24	3	18	14
M27	3	20	16
M30	3,5	20	16
MF3	0,6	3,15	2,5
MF8	1	8	6,3
MF9	1	9	7,1
MF10	1	10	8
MF10	1,25	10	8
MF12	1	9	7,1
MF12	1,25	9	7,1
MF12	1,5	9	7,1
MF14	1,25	11,2	9
MF14	1,5	11,2	9
MF16	1,5	12,5	10
MF18	1,5	14	11,2
MF20	1,5	14	11,2
MF22	1,5	16	12,5
MF24	1,5	18	14

SQUARE DIN 352

o	P	d2	SQUARE
M2	0,4	2,8	2,1
M2,5	0,45	2,8	2,1
M3	0,5	3,5	2,7
M3,5	0,6	4	3
M4	0,7	4,5	3,4
M4,5	0,75	6	4,9
M5	0,8	6	4,9
M6	1	6	4,9
M7	1	6	4,9
M8	1,25	6	4,9
M9	1,25	6	4,9
M10	1,5	7	5,5
M11	1,5	8	6,2
M12	1,75	9	7
M14	2	11	9
M16	2	12	9
M18	2,5	14	11
M20	2,5	16	12
M22	2,5	18	14,5
M24	3	18	14,5
M27	3	20	16
M30	3,5	22	18
M33	3,5	25	20
M36	4	28	22
M39	4	32	24
M42	4,5	32	24
M45	4,5	36	29
M52	5	40	32

SQUARE DIN 352 UNC

o	P	d2	SQUARE
N°2	56	2,8	2,1
N°3	48	3,5	2,7
N°4	40	3,5	2,7
N°5	40	3,5	2,7
N°6	32	4	3
N°8	32	4	3
N°10	24	6	4,9
N°12	24	6	4,9
1/4	20	6	4,9
5/16	18	6	4,9
3/8	16	7	5,5
7/16	14	8	6,2
1/2	13	9	7
9/16	12	11	9
5/8	11	12	9
3/4	10	14	11
7/8	9	18	14,5
1"	8	20	16

SQUARE DIN 352 BSW

o	P	d2	SQUARE
1/8	40	3,5	2,7
5/32	32	4,5	3,4
3/16	24	6	4,9
7/32	24	6	4,9
1/4	20	6	4,9
5/16	18	6	4,9
3/8	16	7	5,5
7/16	14	8	6,2
1/2	12	9	7
9/16	12	9	7
5/18	0	0	-
3/4	10	14	11
7/8	9	18	14,5
1"	8	20	16
1 1/4	7	25	20

SQUARE DIN 374 / 376 M & MF

o	P	d2	SQUARE
M3	0,5	2,7	2,2
M4	0,7	2,8	2,1
M5	0,8	3,5	2,7
M6	1	4,5	3,4
M8	1,25	6	4,9
M10	1,5	7	5,5
M12	1,75	9	7
M14	2	11	9
M16	2	12	9
M18	2,5	14	11
M20	2,5	16	12
M22	2,5	18	14,5
M24	3	18	14,5
M27	3	20	16
M30	3,5	22	18
M33	3,5	25	20
M36	4	28	22
M42	4,5	32	24
M48	5	36	29
MF8	1	6	4,9
MF10	1	7	5,5
MF10	1,25	7	5,5
MF11	1,25	7	5,5+7
MF12	1	9	7
MF12	1,25	9	7
MF12	1,5	9	9
MF14	1	11	9
MF14	1,25	11	9
MF14	1,5	11	9
MF15	1,5	11	9
MF16	1	12	9
MF16	1,25	12	9
MF18	1	14	11
MF18	1,5	14	11
MF18	2	14	11
MF20	1	16	12
MF20	1,5	16	12
MF20	2	16	12
MF22	1,5	18	14,5
MF22	2	18	14,5
MF24	1	18	14,5
MF24	1,5	18	14,5
MF24	2	18	14,5
MF26	1,5	20	16
MF26	2	18	14,5
MF27	1,5	20	16
MF27	2	18	14,5
MF30	1,5	22	18
MF30	2	22	18
MF33	2	25	20

SQUARE DIN 371 M & MF

o	P	d2	SQUARE
M2	0,4	2,8	2,1
M2,5	0,45	2,8	2,1
M3	0,5	3,5	2,7
M3,5	0,6	4	3
M4	0,7	4,5	3,4
M5	0,8	6	4,9
M6	1	6	4,9
M7	1	6	5,5
M8	1,25	8	6,2
M10	1,5	10	8
MF8	1	8	6,2
MF10	1	10	8

SQUARE NFE 66112

o	P	d2	SQUARE
M3	0,5	2,1	1,6
M4	0,7	2,9	2,3
M5	0,8	3,7	3
M6	1	4,5	3,5
M8	1,25	6,2	5
M10	1,5	7,6	6
M12	1,75	9	7
M14	2	10,5	8
M16	2	12,5	10

SQUARE DIN 2181

o	P	d2	SQUARE
MF4	0,5	6	4,9
MF5	0,5	6	4,9
MF5	0,75	6	4,9
MF6	0,75	6	4,9
MF7	0,75	6	4,9
MF8	0,75	6	4,9
MF8	1	6	4,9
MF9	1	7	5,5
MF10	1	7	5,5
MF10	1,25	7	5,5
MF11	1	8	6,2
MF11	1,25	8	6,2
MF12	1	9	7
MF12	1,25	9	7
MF12	1,5	9	7
MF13	1,25	11	9
MF14	1	11	9
MF14	1,25	11	9
MF14	1,5	11	9
MF15	1,5	12	9
MF16	1	12	9
MF16	1,25	12	9
MF16	1,5	12	9
MF18	1	14	11
MF18	1,25	14	11
MF18	1,5	14	11
MF18	2	14	11
MF20	1	16	12
MF20	1,5	16	12
MF20	2	16	12
MF22	1,5	18	14,5
MF22	2	18	14,5
MF24	1	18	14,5
MF24	1,5	18	14,5
MF24	2	18	14,5
MF26	1,5	20	16
MF26	2	18	14,5
MF27	1,5	20	16
MF27	2	18	14,5
MF30	1,5	22	18
MF30	2	22	18
MF33	2	25	20

SQUARE DIN 66101

o	P	d2	SQUARE
M3	0,5	2,3	2,3
M4	0,7	2,9	2,9
M5	0,8	3,8	3,8
M6	1	4,5	4,5
M7	1	5,5	5,5
M8	1,25	6,1	6,1
M10	1,5	7,7	7,7
M12	1,75	9,3	9,3
M14	2	10,9	10,9
M16	2	12,9	12,9
M18	2,5	14,1	14,1
M20	2,5	16,1	16,1
M22	2,5	18	18
M24	3	19,3	19,3
MF6	0,75	4,5	4,5
MF8	1	6,1	6,1
MF10	1	7,7	7,7
MF12	1,25	10,1	10,1
MF12	1,5	9,6	9,6
MF14	1,5	11,8	11,8
MF20	1,5	17,8	17,8
MF22	1,5	19,8	19,8
MF24	1,5	21,8	21,8

SQUARE DIN 2181 UNF

o	P	d2	SQUARE
Nº3	56	3,5	2,7
Nº4	48	3,5	2,7
Nº5	44	3,5	2,7
Nº6	40	4	3
Nº8	36	4	3
Nº10	32	6	4,9
Nº12	28	6	4,9
1/4	28	6	4,9
5/16	24	6	4,9
3/8	24	7	5,5
7/16	20	8	6,2
1/2	20	9	7
9/16	18	12	9
5/8	18	12	9
3/4	16	14	11
7/8	14	18	14,5
1"	12	20	16

SQUARE DIN 2181 BSF

o	P	d2	SQUARE
1/4	26	6	
3/8	20	7	5,5
7/16	18	8	6,2
1/2	16	9	7
9/16	16	11	9
7/8	19,5	14,5	-
1"	10	20	16

SQUARE DIN 5156 BSPG

o	P	d2	SQUARE
G1/8	28	7	5,5
G1/4	19	11	9
G3/8	19	12	9
G1/2	14	16	12
G7/8	14	18	14,5
G3/4	14	18	16
G1"	14	20	20
G1"1/4	11	25	20
G1"1/2	11	36	29

SQUARE sin DIN 5156 NPT

o	P	d2	SQUARE
T 1/16	27	6	4,9
T 1/8	27	8	6,2
T 1/4	18	11	9
T 3/8	18	14	11
T 1/2	14	18	14,5
T 3/4	14	22	18
T 1"	11,5	25	20
T 1"1/4	11,5	32	24

SQUARE sin DIN 5156 RC

o	P	d2	SQUARE
Rc 1/8	27	8	6,2
Rc 1/4	18	11	9
Rc 3/8	18	14	11
Rc 1/2	14	18	14,5
Rc 5/8	14	22	18
Rc 3/4	11,5	25	20

SQUARE sin DIN 40433 Pg

o	P	d2	SQUARE
PG 16	18	18	14,5
PG 21	16	20	16
PG 29	16	28	22

Condiciones de corte | Cutting conditions

Brocas | Drills

Velocidad de corte / Cutting speed Vc (M/min) f (mm/tr)		HSS to HSCo					CARBIDE												
							Standard					Hight performance							
		Vc	f:	Ø2	Ø5	Ø10	Ø15	Vc	f:	Ø2	Ø5	Ø10	Ø15	Vc	f:	Ø2	Ø5	Ø10	Ø15
A	Aceros de construccion o aceros poco aleados Unalloyed & low alloyed steels <400N/mm²	32	f:	0,06	0,12	0,3	0,4	100	f:	0,03	0,05	0,08	0,12	140	f:	0,07	0,13	0,25	0,4
	B	Aceros aleados y tratados Heat Treatable Steels < 700 N/mm²	28	f:	0,06	0,12	0,3	0,4	100	f:	0,03	0,04	0,07	0,1	140	f:	0,06	0,12	0,25
C	Aceros aleados y tratados Heat Treatable Steels < 950 N/mm²	20	f:	0,03	0,07	0,18	0,24	80	f:	0,02	0,03	0,06	0,08	120	f:	0,06	0,12	0,25	0,4
D	Aceros aleados y tratados Heat Treatable Steels < 1200 N/mm²	16	f:	0,04	0,09	0,18	0,28	60	f:	0,02	0,03	0,06	0,08	100	f:	0,06	0,12	0,25	0,4
E	Aceros aleados y tratados Heat Treatable Steels < 1400 N/mm²	NC	f:	-	-	-	-	-	f:	-	-	-	-	-	f:	-	-	-	-
F	Aceros inoxidable, Ferríticos Stainless Steels, Ferritic	16	f:	0,04	0,09	0,21	0,28	60	f:	0,01	0,05	0,08	0,1	70	f:	0,04	0,08	0,15	0,25
G	Aceros inoxidable, Martensíticos Stainless Steels, Martensitic	14	f:	0,03	0,07	0,18	0,28	60	f:	0,01	0,05	0,08	0,1	60	f:	0,03	0,06	0,13	0,2
H	Aceros inoxidable, Austeníticos Stainless Steels, Austenitic	12	f:	0,04	0,09	0,21	0,28	40	f:	0,01	0,05	0,08	0,1	60	f:	0,03	0,06	0,13	0,2
I	Fundición gris Cast Iron	30	f:	0,06	0,12	0,3	0,4	80	f:	0,01	0,05	0,08	0,1	100	f:	0,08	0,16	0,24	0,3

Condiciones de corte | Cutting conditions

Brocas | Drills

Velocidad de corte / Cutting speed

Vc (M/min)
f (mm/tr)

	HSS to HSCo					CARBIDE												
	Vc	f:	Ø2	Ø5	Ø10	Ø15	Standard					Hight performance						
							Vc	f:	Ø2	Ø5	Ø10	Ø15	Vc	f:	Ø2	Ø5	Ø10	Ø15
J Fundición gris con grafito laminar SG Iron	16	f:	0,04	0,09	0,21	0,28	50	f:	0,01	0,05	0,08	0,1	90	f:	0,04	0,08	0,16	0,25
K Aleaciones de aluminio Aluminium Forgings	80	f:	0,05	0,1	0,24	0,32	150	f:	0,03	0,08	0,13	0,16	400	f:	0,03	0,06	0,14	0,24
L Aleaciones de aluminio Cast Aluminium Si < 10%	60	f:	0,04	0,09	0,21	0,28	150	f:	0,03	0,08	0,13	0,16	350	f:	0,02	0,05	0,12	0,2
M Aleaciones de aluminio Cast Aluminium Si > 10%	40	f:	0,04	0,09	0,21	0,28	80	f:	0,01	0,06	0,09	0,12	300	f:	0,02	0,05	0,12	0,2
N Latón Brass	60	f:	0,05	0,1	0,24	0,32	100	f:	0,03	0,06	0,1	0,15	nc	f:	nc	nc	nc	nc
O Bronce Bronze	60	f:	0,04	0,09	0,21	0,28	100	f:	0,02	0,05	0,09	0,12	nc	f:	nc	nc	nc	nc
ARC0/ AR Ni Aleaciones refractarias, base Co Ni Special Alloys based Co Ni	10	f:	0,02	0,04	0,1	0,17	20	f:	0,01	0,03	0,05	0,08	30	f:	0,02	0,05	0,1	0,16
Ti Aleaciones de titanio Titan alloys	10	f:	0,02	0,04	0,1	0,17	20	f:	0,01	0,03	0,05	0,08	30	f:	0,02	0,05	0,1	0,16

Condiciones de corte | Cutting conditions

Machos | Taps

Velocidad de corte / Cutting speed

Vc (M/min)

Recubrimiento / coating = Vc + 20 => 50%



A	Aceros de construcción o aceros poco aleados Unalloyed & low alloyed steels <400N/mm²	25-30	18-20	18-20	15-18
					15-18
B	Aceros aleados y tratados Heat Treatable Steels < 700 N/mm²	20-30	15-18	15-18	20-25
C	Aceros aleados y tratados Heat Treatable Steels < 950 N/mm²		6-8	6-8	5-8
D	Aceros aleados y tratados Heat Treatable Steels < 1200 N/mm²		4-6	4-6	2-5
E	Aceros aleados y tratados Heat Treatable Steels < 1400 N/mm²			3-5	3-5
F	Aceros inoxidable, ferríticos Stainless Steels, Ferritic	10-20		6-8	6-8
G	Aceros inoxidable, Martensíticos Stainless Steels, Martensitic			4-6	4-6
H	Aceros inoxidable, Austeníticos Stainless Steels, Austenitic			5-7	5-7
I	Fundición gris Cast Iron		15-20		

Condiciones de corte | Cutting conditions

Machos | Taps

Velocidad de corte / Cutting speed

V_c (M/min) Recubrimiento / coating = $V_c + 20 \Rightarrow 50\%$



J	Fundición gris con grafito laminar SG Iron		10-15		
K	Aleaciones de aluminio Aluminium Forgings	30-40		15-25	15-25
L	Aleaciones de aluminio Cast Aluminium Si < 10%	12-20		12-18	12-18
M	Aleaciones de aluminio Cast Aluminium Si > 10%	12-20		12-18	12-18
N	Latón Brass	25-30	18-20	18-20	15-18
O	Bronce Bronze		5-10	5-10	5-10
ARCO/ AR Ni	Aleaciones refractarias, base Co Ni Special Alloys based Co Ni		2-4	2-4	2-4
Ti	Aleaciones de titanio Titan alloys			3-5	3-5

Condiciones de corte | Cutting conditions

Fresas limas | Rotary burs

Velocidad de corte / Cutting speed

Vc (M/min)

Recubrimiento / coating = Vc + 20 => 50%



	A	C	D
A	Aceros de construcción o aceros poco aleados Unalloyed & low alloyed steels <400N/mm² 400>800 m/min		
B	Aceros aleados y tratados Heat Treatable Steels < 700 N/mm² 400>800 m/min		
C	Aceros aleados y tratados Heat Treatable Steels < 950 N/mm² 400>800 m/min		
D	Acier pour traitement thermique Staal voor thermische behandeling Vergütungsstähle Heat Treatable Steels Aceros aleados y tratados Acciai per trattamento termico < 1200 N/mm² 300>700 m/min		
E	Aceros aleados y tratados Heat Treatable Steels < 1400 N/mm² 300>600 m/min		
F	Aceros inoxidables, ferríticos Stainless Steels, Ferritic 600>1000 m/min		
G	Aceros inoxidables, Martensíticos Stainless Steels, Martensitic 600>1000 m/min		
H	Aceros inoxidables, Austeníticos Stainless Steels, Austenitic 600>1000 m/min		
I	Fundición gris Cast Iron 500>800 m/min		

Condiciones de corte | Cutting conditions

Fresas limas | Rotary burs

Velocidad de corte / Cutting speed

Vc (M/min) Recubrimiento / coating = Vc + 20 => 50%



	A	C	D
J Fundición gris con grafito laminar SG Iron		500>800 m/min	
K Aleaciones de aluminio Aluminium Forgings	400>1000 m/min		
L Aleaciones de aluminio Cast Aluminium Si < 10%	400>1000 m/min		
M Aleaciones de aluminio Cast Aluminium Si > 10%	300>7000 m/min		
N Latón Brass			400>800 m/min
O Bronce Bronze			400>800 m/min
ARCO/ AR Ni Aleaciones refractarias, base Co Ni Special Alloys based Co Ni		400>800 m/min	400>800 m/min
Ti Aleaciones de titanio Titan alloys	400>1000 m/min		

Fresado Condiciones de corte (Part.A) | End milling Cutting conditions

Vc and Vc'(Coated) = m/min
fz = m/tr

Class	Material	Ø	Vc/fz	HSS to HSSPM			HM carbide regular			HM carbide high perf. <small>(23621, 23623, 23640, 23642, 23634, 23636)</small>		
				0,5d	d	1d	0,5d	d	1d	0,5d	d	1d
A	Aceros de construccion o aceros poco aleados Unalloyed & low alloyed steels <400N/mm ²		Vc	38 to 44 m/min			80 to 120 m/min			145 to 190 m/min (recub.,coated)		
			Vc(C)	65 to 75 m/min (recub.,coated)			96 to 144 m/min (recub.,coated)			145 to 190 m/min (recub.,coated)		
		4	fz	0,017	0,015	0,022	0,017	0,015	0,022	0,013	0,015	0,038
		6	fz	0,023	0,021	0,029	0,023	0,021	0,029	0,027	0,031	0,077
		8	fz	0,037	0,350	0,049	0,037	0,350	0,049	0,038	0,043	0,108
		10	fz	0,041	0,038	0,054	0,041	0,038	0,054	0,047	0,054	0,134
		12	fz	0,050	0,046	0,065	0,050	0,046	0,065	0,062	0,071	0,178
		20	fz	0,057	0,053	0,075	0,057	0,053	0,075	0,082	0,094	0,235
B	Aceros aleados y tratados Heat Treatable Steels < 700 N/mm ²		Vc	32 to 38 m/min			60 to 100 m/min			120 to 170 m/min (recub.,coated)		
			Vc(C)	55 to 70 m/min (recub.,coated)			72 to 120 m/min (recub.,coated)			120 to 170 m/min (recub.,coated)		
		4	fz	0,018	0,016	0,023	0,018	0,016	0,023	0,012	0,014	0,035
		6	fz	0,027	0,024	0,035	0,027	0,024	0,035	0,025	0,028	0,070
		8	fz	0,039	0,036	0,051	0,039	0,036	0,051	0,035	0,040	0,099
		10	fz	0,044	0,041	0,058	0,044	0,041	0,058	0,043	0,049	0,123
		12	fz	0,053	0,049	0,069	0,053	0,049	0,069	0,057	0,065	0,163
		20	fz	0,060	0,055	0,079	0,060	0,055	0,079	0,075	0,086	0,216
C	Aceros aleados y tratados Heat Treatable Steels < 950 N/mm ²		Vc	30 to 36 m/min			60 to 80 m/min			100 to 130 m/min (coated/revêtu)		
			Vc(C)	50 to 65 m/min (recub.,coated)			75 to 95 m/min (recub.,coated)			100 to 130 m/min (coated/revêtu)		
		4	fz	0,017	0,016	0,022	0,017	0,016	0,022	0,011	0,013	0,032
		6	fz	0,025	0,023	0,033	0,025	0,023	0,033	0,022	0,026	0,064
		8	fz	0,039	0,036	0,052	0,039	0,036	0,052	0,032	0,036	0,090
		10	fz	0,047	0,043	0,061	0,047	0,043	0,061	0,039	0,045	0,112
		12	fz	0,050	0,047	0,066	0,050	0,047	0,066	0,052	0,059	0,148
		20	fz	0,060	0,055	0,079	0,060	0,055	0,079	0,069	0,078	0,196
D	Aceros aleados y tratados Heat Treatable Steels < 1200 N/mm ²		Vc	22 to 28 m/min			40 to 60 m/min			75 to 100 m/min (recub.,coated)		
			Vc(C)	42 to 50 m/min (recub.,coated)			55 to 75 m/min (recub.,coated)			75 to 100 m/min (recub.,coated)		
		4	fz	0,014	0,012	0,017	0,014	0,012	0,017	0,010	0,012	0,029
		6	fz	0,021	0,018	0,026	0,021	0,018	0,026	0,020	0,023	0,058
		8	fz	0,033	0,029	0,041	0,033	0,029	0,041	0,028	0,032	0,081
		10	fz	0,038	0,033	0,047	0,038	0,033	0,047	0,035	0,040	0,101
		12	fz	0,041	0,036	0,052	0,041	0,036	0,052	0,047	0,053	0,133
		20	fz	0,050	0,044	0,063	0,050	0,044	0,063	0,062	0,071	0,176
E	Aceros aleados y tratados Heat Treatable Steels < 1400 N/mm ²		Vc	16 to 22 m/min			25 to 40 m/min			55 to 75 m/min (recub.,coated)		
			Vc(C)	30 to 36 m/min (recub.,coated)			40 to 55 m/min (recub.,coated)			55 to 75 m/min (recub.,coated)		
		4	fz	0,014	0,012	0,017	0,014	0,012	0,017	0,008	0,009	0,022
		6	fz	0,021	0,018	0,026	0,021	0,018	0,026	0,016	0,018	0,045
		8	fz	0,033	0,029	0,041	0,033	0,029	0,041	0,022	0,025	0,063
		10	fz	0,038	0,033	0,047	0,038	0,033	0,047	0,027	0,031	0,078
		12	fz	0,041	0,036	0,052	0,041	0,036	0,052	0,036	0,041	0,104
		20	fz	0,050	0,044	0,063	0,050	0,044	0,063	0,048	0,055	0,137
F	Aceros inoxidables, ferriticos Stainless Steels, Ferritic		Vc	18 to 24 m/min			60 to 80 m/min			95 to 125 m/min (recub.,coated)		
			Vc(C)	30 to 36 m/min (recub.,coated)			75 to 95 m/min (recub.,coated)			95 to 125 m/min (recub.,coated)		
		4	fz	0,010	0,009	0,013	0,010	0,009	0,013	0,011	0,013	0,032
		6	fz	0,022	0,019	0,027	0,022	0,019	0,027	0,022	0,026	0,064
		8	fz	0,033	0,029	0,042	0,033	0,029	0,042	0,032	0,036	0,090
		10	fz	0,043	0,038	0,054	0,043	0,038	0,054	0,039	0,045	0,112
		12	fz	0,054	0,047	0,067	0,054	0,047	0,067	0,052	0,059	0,148
		20	fz	0,067	0,059	0,084	0,067	0,059	0,084	0,069	0,078	0,196
G	Aceros inoxidables, Martensiticos Stainless Steels, Martensitic		Vc	16 to 22 m/min			40 to 60 m/min			75 to 105 m/min (recub.,coated)		
			Vc(C)	28 to 34 m/min (recub.,coated)			55 to 75 m/min (recub.,coated)			75 to 105 m/min (recub.,coated)		
		4	fz	0,010	0,009	0,013	0,010	0,009	0,013	0,010	0,012	0,029
		6	fz	0,022	0,019	0,027	0,022	0,019	0,027	0,020	0,023	0,058
		8	fz	0,033	0,029	0,042	0,033	0,029	0,042	0,028	0,032	0,081
		10	fz	0,043	0,038	0,054	0,043	0,038	0,054	0,035	0,040	0,101
		12	fz	0,054	0,047	0,067	0,054	0,047	0,067	0,047	0,053	0,133
		20	fz	0,067	0,059	0,084	0,067	0,059	0,084	0,062	0,071	0,176
H	Aceros inoxidables, Austeniticos Stainless Steels, Austenitic		Vc	14 to 18 m/min			25 to 40 m/min			55 to 75 m/min (recub.,coated)		
			Vc(C)	22 to 26 m/min (recub.,coated)			40 to 55 m/min (recub.,coated)			55 to 75 m/min (recub.,coated)		
		4	fz	0,010	0,009	0,013	0,010	0,009	0,013	0,009	0,010	0,026
		6	fz	0,022	0,019	0,027	0,022	0,019	0,027	0,018	0,020	0,051
		8	fz	0,033	0,029	0,042	0,033	0,029	0,042	0,025	0,029	0,072
		10	fz	0,043	0,038	0,054	0,043	0,038	0,054	0,031	0,036	0,090
		12	fz	0,054	0,047	0,067	0,054	0,047	0,067	0,041	0,047	0,118
		20	fz	0,067	0,059	0,084	0,067	0,059	0,084	0,055	0,063	0,157

Fresado Condiciones de corte (Part.B) | End milling Cutting conditions

Class	Material	Ø	Vc/fz	HSS to HSSPM			HM carbide regular			HM carbide high perf. <small>(23621, 23623, 23640, 23642, 23634, 23636)</small>		
				0,5d	d	1,1d	0,5d	d	1,1d	0,5d	d	1,1d
I	Fontes grises Grau gietzjer Cast Iron Fundicion gris Ghisa grigia	4	Vc	34 to 40 m/min			80 to 100 m/min			130 to 160 m/min (recub.)coated		
			Vc(C)	60 to 70 m/min (recub.)coated			100 to 130 m/min (recub.)coated			130 to 160 m/min (recub.)coated		
		6	fz	0,020	0,017	0,025	0,020	0,017	0,025	0,013	0,015	0,038
		8	fz	0,034	0,030	0,042	0,034	0,030	0,042	0,027	0,031	0,077
		10	fz	0,045	0,039	0,056	0,045	0,039	0,056	0,038	0,043	0,108
		12	fz	0,054	0,047	0,067	0,054	0,047	0,067	0,047	0,054	0,134
		16	fz	0,059	0,052	0,074	0,059	0,052	0,074	0,062	0,071	0,178
		20	fz	0,068	0,060	0,085	0,068	0,060	0,085	0,082	0,094	0,235
		20	fz	0,081	0,071	0,101	0,081	0,071	0,101	0,102	0,117	0,293
		J	Fontes GS Gietzjer SG SG Guss SG Iron Fundicion gris con grafito laminar Ghisa a Grafite Sferoidale	4	Vc	20 to 24 m/min			50 to 70 m/min			100 to 130 m/min (recub.)coated
Vc(C)	38 to 44 m/min (recub.)coated				75 to 100 m/min (recub.)coated			100 to 130 m/min (recub.)coated				
6	fz			0,020	0,017	0,025	0,020	0,017	0,025	0,012	0,014	0,035
8	fz			0,034	0,030	0,042	0,034	0,030	0,042	0,025	0,028	0,070
10	fz			0,045	0,039	0,056	0,045	0,039	0,056	0,035	0,040	0,099
12	fz			0,054	0,047	0,067	0,054	0,047	0,067	0,043	0,049	0,123
16	fz			0,059	0,052	0,074	0,059	0,052	0,074	0,057	0,065	0,163
20	fz			0,068	0,060	0,085	0,068	0,060	0,085	0,075	0,086	0,216
20	fz			0,081	0,071	0,101	0,081	0,071	0,101	0,094	0,107	0,268
K	Alliages d'aluminium gras Zuivere aluminiumlegeringen Reinaluminium Aluminium Forgings Aleaciones de aluminio Laminato (Al)			4	Vc	150 to 250 m/min			350 to 500 m/min			600 to 800 m/min (recub.)coated
		Vc(C)	200 to 300 m/min (recub.)coated			450 to 650 m/min (recub.)coated			600 to 800 m/min (recub.)coated			
		6	fz	0,025	0,022	0,031	0,025	0,022	0,031	0,016	0,018	0,045
		8	fz	0,038	0,033	0,047	0,038	0,033	0,047	0,031	0,036	0,090
		10	fz	0,052	0,046	0,065	0,052	0,046	0,065	0,044	0,050	0,126
		12	fz	0,059	0,052	0,074	0,059	0,052	0,074	0,055	0,063	0,157
		16	fz	0,066	0,058	0,082	0,066	0,058	0,082	0,073	0,083	0,207
		20	fz	0,085	0,075	0,106	0,085	0,075	0,106	0,096	0,110	0,274
		20	fz	0,091	0,080	0,114	0,091	0,080	0,114	0,120	0,137	0,342
		L	Alliages d'aluminium Aluminiumlegeringen Aluminium-legierungen Cast Aluminium Aleaciones de aluminio Stampate Al Si < 10%	4	Vc	100 to 150 m/min			250 to 400 m/min			500 to 700 m/min (recub.)coated
Vc(C)	150 to 200 m/min (recub.)coated				300 to 550 m/min (recub.)coated			500 to 700 m/min (recub.)coated				
6	fz			0,028	0,024	0,035	0,028	0,024	0,035	0,015	0,017	0,042
8	fz			0,041	0,036	0,052	0,041	0,036	0,052	0,029	0,033	0,083
10	fz			0,057	0,050	0,071	0,057	0,050	0,071	0,041	0,047	0,117
12	fz			0,065	0,057	0,081	0,065	0,057	0,081	0,051	0,058	0,146
16	fz			0,073	0,064	0,091	0,073	0,064	0,091	0,067	0,077	0,192
20	fz			0,093	0,082	0,117	0,093	0,082	0,117	0,089	0,102	0,255
20	fz			0,100	0,088	0,125	0,100	0,088	0,125	0,111	0,127	0,317
M	Alliages d'aluminium Aluminiumlegeringen Aluminium-legierungen Cast Aluminium Aleaciones de aluminio Stampate Al Si > 10%			4	Vc	60 to 100 m/min			150 to 300 m/min			350 to 500 m/min (coated/revêtu)
		Vc(C)	80 to 120 m/min (recub.)coated			200 to 400 m/min (coated/revêtu)			350 to 500 m/min (coated/revêtu)			
		6	fz	0,030	0,027	0,038	0,030	0,027	0,038	0,013	0,015	0,038
		8	fz	0,046	0,040	0,057	0,046	0,040	0,057	0,027	0,031	0,077
		10	fz	0,063	0,055	0,078	0,063	0,055	0,078	0,038	0,043	0,108
		12	fz	0,071	0,063	0,089	0,071	0,063	0,089	0,047	0,054	0,134
		16	fz	0,080	0,070	0,100	0,080	0,070	0,100	0,062	0,071	0,178
		20	fz	0,103	0,090	0,128	0,103	0,090	0,128	0,082	0,094	0,235
		20	fz	0,110	0,097	0,138	0,110	0,097	0,138	0,102	0,117	0,293
		N	Latón Brass	4	Vc	70 to 95 m/min			100 to 200 m/min			150 to 250 m/min (coated/revêtu)
Vc(C)	100 to 180 m/min (coated/revêtu)				120 to 240 m/min (coated/revêtu)			150 to 250 m/min (coated/revêtu)				
6	fz			0,011	0,009	0,013	0,011	0,009	0,013	0,011	0,013	0,032
8	fz			0,019	0,017	0,024	0,019	0,017	0,024	0,022	0,026	0,064
10	fz			0,031	0,028	0,039	0,031	0,028	0,039	0,032	0,036	0,090
12	fz			0,039	0,035	0,049	0,039	0,035	0,049	0,039	0,045	0,112
16	fz			0,053	0,047	0,066	0,053	0,047	0,066	0,052	0,059	0,148
20	fz			0,071	0,062	0,088	0,071	0,062	0,088	0,069	0,078	0,196
20	fz			0,079	0,069	0,090	0,079	0,069	0,090	0,085	0,098	0,244
O	Bronce Bronze			4	Vc	50 to 75 m/min			75 to 125 m/min			130 to 180 m/min (coated/revêtu)
		Vc(C)	80 to 120 m/min (coated/revêtu)			110 to 160 m/min (coated/revêtu)			130 to 180 m/min (coated/revêtu)			
		6	fz	0,011	0,009	0,013	0,011	0,009	0,013	0,011	0,013	0,032
		8	fz	0,019	0,017	0,024	0,019	0,017	0,024	0,022	0,026	0,064
		10	fz	0,031	0,028	0,039	0,031	0,028	0,039	0,032	0,036	0,090
		12	fz	0,039	0,035	0,049	0,039	0,035	0,049	0,039	0,045	0,112
		16	fz	0,053	0,047	0,066	0,053	0,047	0,066	0,052	0,059	0,148
		20	fz	0,071	0,062	0,088	0,071	0,062	0,088	0,069	0,078	0,196
		20	fz	0,079	0,069	0,090	0,079	0,069	0,090	0,085	0,098	0,244
		AIR ARFe	Aleaciones refractarias, base Co Ni Special Alloys based Co Ni	4	Vc	12 to 18 m/min			30 to 45 m/min			45 to 65 m/min (recub.)coated
Vc(C)	18 to 24 m/min (recub.)coated				35 to 50 m/min (recub.)coated			45 to 65 m/min (recub.)coated				
6	fz			0,009	0,008	0,012	0,009	0,008	0,012	0,008	0,009	0,022
8	fz			0,019	0,017	0,024	0,019	0,017	0,024	0,016	0,018	0,045
10	fz			0,030	0,027	0,038	0,030	0,027	0,038	0,022	0,025	0,063
16	fz			0,039	0,034	0,049	0,039	0,034	0,049	0,027	0,031	0,078
20	fz			0,048	0,043	0,061	0,048	0,043	0,061	0,036	0,041	0,104
20	fz	0,060	0,053	0,075	0,060	0,053	0,075	0,048	0,055	0,137		
20	fz	0,067	0,059	0,084	0,067	0,059	0,084	0,060	0,068	0,171		

Fresado Condiciones de corte (Part.C) | End milling Cutting conditions

Class	Material	Ø	Vc and Vc'(Coated) = m/min fz = m/tr	HSS to HSSPM			HM carbide regular			HM carbide high perf. <small>(23621, 23623, 23640, 23642, 23634, 23636)</small>		
				0,5d	d	a	0,5d	d	a	0,5d	d	a
ARCo ARNi	Aleaciones refractarias, base Co Ni <small>Special Alloys based Co Ni</small>	4	Vc	10 to 16 m/min			25 to 40 m/min			40 to 60 m/min (recub.,coated)		
			Vc(C)	20 to 26 m/min (recub.,coated)			30 to 45 m/min (recub.,coated)			40 to 60 m/min (recub.,coated)		
		6	fz	0,013	0,012	0,016	0,013	0,012	0,016	0,007	0,008	0,019
			fz	0,022	0,019	0,027	0,022	0,019	0,027	0,013	0,015	0,038
		8	fz	0,033	0,029	0,042	0,033	0,029	0,042	0,019	0,022	0,054
			fz	0,044	0,039	0,056	0,044	0,039	0,056	0,024	0,027	0,067
		12	fz	0,057	0,050	0,071	0,057	0,050	0,071	0,031	0,036	0,089
			fz	0,067	0,059	0,084	0,067	0,059	0,084	0,041	0,047	0,118
20	fz	0,079	0,069	0,098	0,079	0,069	0,098	0,051	0,059	0,146		
	Vc	8 to 12 m/min			20 to 35 m/min			35 to 55 m/min (recub.,coated)				
ARCo ARNi	Aleaciones refractarias, base Co Ni <small>Special Alloys based Co Ni</small>	4	Vc(C)	14 to 16 m/min (recub.,coated)			25 to 40 m/min (recub.,coated)			35 to 55 m/min (recub.,coated)		
			fz	0,011	0,010	0,014	0,011	0,010	0,014	0,007	0,008	0,019
		6	fz	0,018	0,016	0,023	0,018	0,016	0,023	0,013	0,015	0,038
			fz	0,029	0,025	0,036	0,029	0,025	0,036	0,019	0,022	0,054
		8	fz	0,038	0,034	0,048	0,038	0,034	0,048	0,024	0,027	0,067
			fz	0,048	0,043	0,061	0,048	0,043	0,061	0,031	0,036	0,089
		12	fz	0,057	0,051	0,072	0,057	0,051	0,072	0,041	0,047	0,118
			fz	0,067	0,059	0,084	0,067	0,059	0,084	0,051	0,059	0,146
20	Vc	12 to 18 m/min			20 to 40 m/min			45 to 65 m/min 55 to 75 m/min 75 to 85 m/min				
	Vc(C)	22 to 28 m/min (recub.,coated)			24 to 48 m/min (recub.,coated)			45 to 65 m/min 55 to 75 m/min 75 to 85 m/min				
Ti	Aleaciones de titanio <small>Titan alloys</small>	4	fz	0,011	0,010	0,014	0,011	0,010	0,014	0,008	0,009	0,022
			fz	0,017	0,016	0,023	0,017	0,016	0,023	0,016	0,018	0,045
		6	fz	0,027	0,025	0,036	0,027	0,025	0,036	0,022	0,025	0,063
			fz	0,036	0,034	0,048	0,036	0,034	0,048	0,027	0,031	0,078
		8	fz	0,046	0,043	0,061	0,046	0,043	0,061	0,036	0,041	0,104
			fz	0,055	0,051	0,072	0,055	0,051	0,072	0,048	0,055	0,137
		12	fz	0,064	0,059	0,084	0,064	0,059	0,084	0,060	0,068	0,171
			fz	0,064	0,059	0,084	0,064	0,059	0,084	0,060	0,068	0,171



CONDICIONES DE VENTA
CONDITIONS OF SALE

CATÁLOGO GENERAL
2021

CONDICIONES GENERALES DE VENTA

1. PREÁMBULO

Las presentes condiciones son aplicables con independencia de las condiciones generales del comprador. Cualquier modificación que las partes realicen requiere un acuerdo expreso por escrito.

2. APERTURA DE CUENTA Y CONDICIONES DE CRÉDITO

La apertura de cuenta o la aplicación de nuestras condiciones comerciales está subordinada a la obtención de los documentos (jurídicos, nancieros) o garantías que estimamos necesarios.

TIVOLY se reserva la posibilidad de establecer un límite de cuantía más allá de la cual puede exigirse un pago al contado.

3. PRECIO

Los precios practicados son los correspondientes a la tarifa vigente en la fecha de recepción del pedido en la sede de TIVOLY.

4. PEDIDO

No se acusa recibo de los pedidos: cualquier pedido no rechazado por escrito en un plazo de quince días a partir de su recepción en la sede social de TIVOLY se considera aceptado.

5. FABRICACIONES ESPECIALES

Salvo convenios específicos, por razones técnicas de fabricación de artículos que requieran una fabricación especial, nos reservamos el derecho de suministrar y facturar un 10% de más o de menos con relación a la cantidad objeto del pedido. Respecto a los pedidos de menos de 10 piezas, esta tolerancia podrá ser de 2 piezas.

6. CONDICIONES DE PAGO

Pago a 60 días f.f. : Neto

Pago a 30 días f.f. : descuento 0,5 %

Reposición : 1 %

7. PLAZOS DE ENTREGA

TIVOLY se compromete a respetar en la medida de lo posible los plazos estipulados. No obstante, los plazos de entrega indicados no son de rigor y el comprador no podrá invocarlos en caso de retrasos eventuales para anular el pedido o reclamar una indemnización por daños y perjuicios o penalizaciones.

8. TRANSPORTE

Las mercancías vendidas viajan por cuenta y riesgo del comprador con independencia del modo de transporte.

Conforme a los artículos L133-3 y siguientes del Código de Comercio, corresponde a los destinatarios ejercer sus recursos contra los transportistas en las formas y plazos legales.

Pedidos inferiores a 260 euros NETOS: PORTES DEBIDOS.

Pedidos superiores a 260 euros NETOS: PORTES PAGADOS.

En cualquier caso el vendedor se reserva el derecho de utilizar el medio de envío más económico.

En las poblaciones donde NECO tenga establecidos depósitos de distribución, esta cláusula se aplicará para las reexpediciones a otras poblaciones.

En envíos a la península de carácter urgente, cuya cuantía sea inferior a 260 euros y hasta un peso de 15 kilogramos, se cargará en concepto de portes 5,70 euros en la factura.

En envíos a Canarias y Andorra, para pedidos superiores a 700 euros: PORTES PAGADOS. Para pedidos inferiores, se cargará un porte de 33 euros.

9. ENTREGA - RECLAMACIÓN

En caso de mercancías faltantes o de deterioro de productos en la llegada, el destinatario debe hacer lo siguiente:

- anotar en el resguardo del transportista sus reservas, indicando de manera precisa el número exacto de paquetes faltantes o deteriorados y objeto de la reclamación, y conmarlas al transportista en un plazo de 3 días por carta certificada,
- enviar un duplicado de estas reservas a TIVOLY en un plazo de 48 horas a partir de la entrega, indicando las referencias del pedido

Cualquier reclamación debe ponerse en conocimiento del Servicio Comercial, en la sede social de TIVOLY, en un plazo máximo de 10 días a partir de la recepción de las mercancías si el conicto se reere a estas, o de 30 días de la fecha de la factura si el conicto concierne a la facturación.

10. DEVOLUCIÓN DE MERCANCÍAS

No debe realizarse devolución alguna de mercancías sin nuestro consentimiento expreso (acuerdo por escrito del Servicio Comercial).

En caso de aceptación de la devolución, se aplicará un descuento del 15 % en el precio de las mercancías. La devolución se realizará a portes pagados salvo excepción.

11. RESERVA DE PROPIEDAD (Ley de 15 de enero 1985)

TIVOLY se reserva la propiedad de las mercancías suministradas hasta el pago completo del precio y sus gastos accesorios.

No obstante, los riesgos corridos tras el envío son asumidos por el comprador.

Ni la acción de reventa de los bienes ni su pago por parte de un tercero afectan a los efectos de la cláusula cuya validez solo cesa con la extinción del crédito de TIVOLY. En caso de administración o liquidación judicial, la acción de reventa se retira automáticamente. En consecuencia, el vendedor podrá reivindicar las mercancías que no hayan sido revendidas mientras que el pago no se haya efectuado íntegramente. Este último conservará en concepto de indemnización cualquier suma abonada como anticipo. El comprador se compromete a adoptar cualquier medida para que las mercancías se individualicen como propiedad del vendedor.

12. GARANTÍA - RESPONSABILIDAD

Garantizamos que nuestros productos respetan las especificaciones que guran en los catálogos. Se admite una tolerancia en la medida en que se respeten las normas vigentes.

De manera general, no podrá considerarse responsable a TIVOLY en ningún caso si el empleo, manipulación, transformación, almacenamiento o transporte de los productos vendidos causan al comprador, su clientela u otros terceros cualquier daño, ya se trate de accidentes personales, daños a bienes distintos del objeto del contrato o pérdidas nancieras. El comprador no podrá hacer valer un recurso de garantía para suspender o diferir sus pagos.

13. PROPIEDAD INDUSTRIAL - CONFIDENCIALIDAD

TIVOLY es la propietaria exclusiva de los estudios, planos y modelos que hayan podido llegar a conocimiento del comprador en el marco del contrato. Cualquier incumplimiento de estas normas podrá dar lugar a acciones legales.

14. EXCEPCIÓN

Cualquier excepción de las presentes condiciones generales de venta y en particular las condiciones de compra del comprador solo son válidas tras su aceptación por escrito por nuestra parte.

15. JURISDICCIÓN

En caso de litigio, la competencia corresponde exclusivamente al Tribunal de la jurisdicción de la rma vendedora.

16. NULIDAD

La nulidad parcial o total de cualquiera de las disposiciones de las presentes condiciones generales de venta no afectará a la validez de las demás disposiciones.



MERCHANDISING

Expositores y materiales de PLV

Para desarrollar las ventas Tivoly propone lineales y soluciones a medida. Tivoly dispone de diferentes materiales de exposición y comunicación para el punto de venta, que se adapta a cada gama de productos.

Para ello, Tivoly propone diferentes soluciones de exposición adaptadas a cada superficie de venta. Nuestro equipo Comercial y de Márketing le ayudará en la planificación y organización del lineal para optimizar sus ventas.

Displays, communication and promotional materials

To drive sales and animate the shelves, Tivoly offers customized highlighted solutions for promotions, cross-marketing etc....

For each product line, Tivoly offers the implantation of an assortment of products adapted to your sales floor needs. Our sales representatives and consultants will listen to you to define the way you want to organize the product range for maximum sales.



EXPOSITORES Y MATERIALES DE PLV

DISPLAYS, COMMUNICATION AND PROMOTIONAL MATERIALS



9130100 0414
Expositor
Display
220 x 100 cm

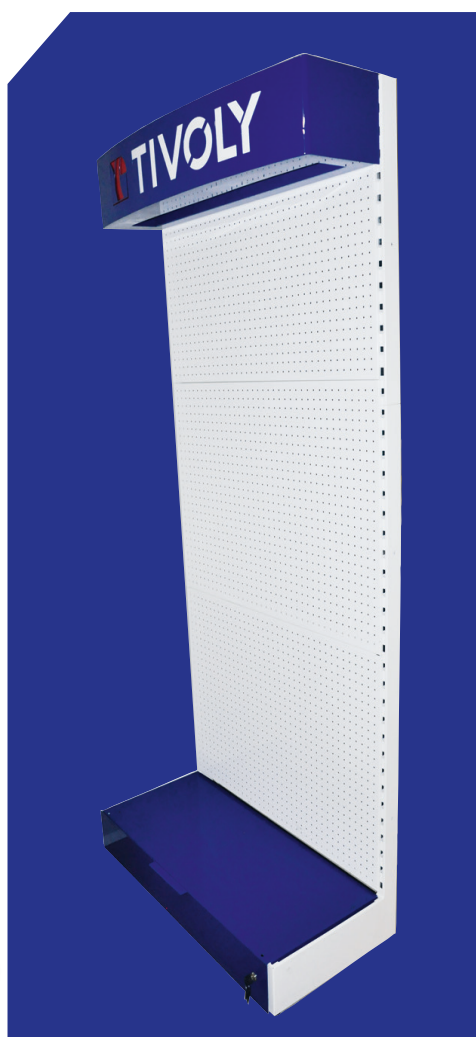
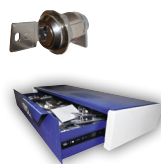

9130100 0417
Soporte + 20
ganchos
Rack + 20 pins
100 x 32 x 18 cm

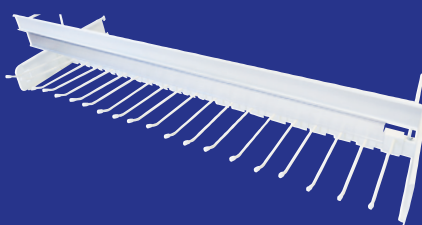

9130100 0415
Vitrina
Showcase
100 x 37 x 30 cm

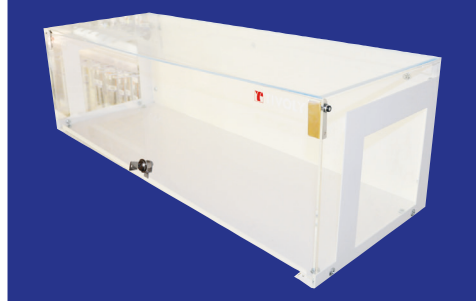

9130100 0416
Armario 4 cajones
4 drawers block
100 x 43 x 35 cm

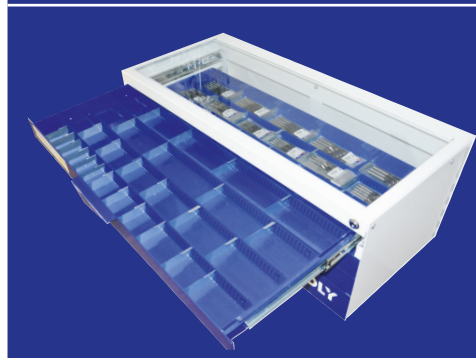

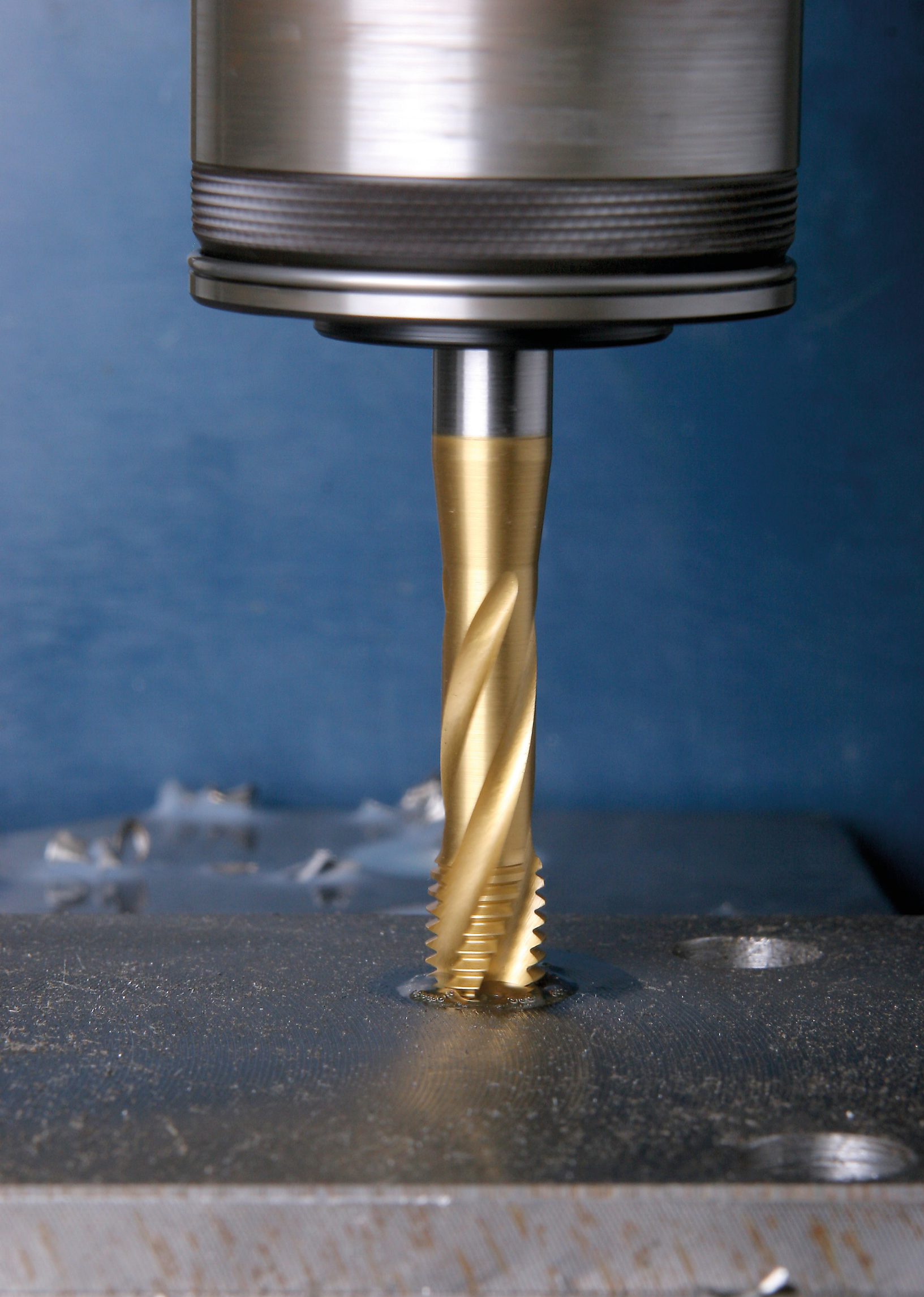



**HERRAMIENTAS
DE CORTE**

CATÁLOGO

CUTTING TOOLS

CATALOGUE

2021v.SP

